











PLA
BOMBAS DE ENGRANAJES
GEAR PUMPS

Roquet
making moves

Empresa	3
Información general	4
Bomba de engranajes PLA/PLAN 	
Datos técnicos	5
Sistema de codificación	8
Tipos de ejes motriz	9
Tipos de tapas frontales	10
Tipos de conexión tomas	11
Tapa tipo 01	12
Tapa tipo 10	13
Tapa tipo 23	14
Tapa tipo 19	15
Tapa tipo 09	16
Bomba de engranajes PLL/PLLN (PLA+PLA / PLAN+PLAN) 	
Tapa tipo 10	17
Bomba de engranajes PLD/PLDN (PLA+L / PLAN+L) 	
Tapa tipo 10	18
Bomba de engranajes PLT/PLTN (PLA+L0 / PLAN+L0) 	
Tapa tipo 10	19
Otras opciones	
Conexión con tomas T	20
Tapa trasera para bombas reversibles	20
Tipos de polea	20
Tapa tipo 50	21
Bomba con válvula limitadora	22
Recambios	
Bomba PLA/PLAN	23
Bomba PLL/PLLN (PLA+PLA / PLAN+PLAN)	24
Bomba PLD/PLDN (PLA+L / PLAN+L)	25
Bomba PLT/PLTN (PLA+L0 / PLAN+L0)	26

Company	3
Information	4
Gear pump PLA/PLAN 	
Technical data	5
Coding system	8
Drive shaft forms	9
Front flange types	10
Port connection forms	11
Front flange type 01	12
Front flange type 10	13
Front flange type 23	14
Front flange type 19	15
Front flange type 09	16
Gear pump PLL/PLLN (PLA+PLA / PLAN+PLAN) 	
Front flange type 10	17
Gear pump PLD/PLDN (PLA+L / PLAN+L) 	
Front flange type 10	18
Gear pump PLT/PLTN (PLA+L0 / PLAN+L0) 	
Front flange type 10	19
Other options	
Port connection form T	20
Back cover for reversible pumps	20
Types of pulley	20
Front flange type 50	21
Pump with relief valve	22
Spare parts	
Pump PLA/PLAN	23
Pump PLL/PLLN (PLA+PLA / PLAN+PLAN)	24
Pump PLD/PLDN (PLA+L / PLAN+L)	25
Pump PLT/PLTN (PLA+L0 / PLAN+L0)	26

HISTORIA Más de medio siglo de trayectoria especializada en oleodinámica. Roquet es proveedor internacional en los sectores agrícola, naval, manutención, máquina-herramienta, automoción pesada, maquinaria de obras públicas, minería, eólica, alimentación, etc. Marca líder en España y una referencia importante en el ámbito internacional.

TECNOLOGÍA Roquet dispone de un importante departamento de diseño y desarrollo, con bancos de prueba de fatiga, nivel sonoro, resistencia a la corrosión, etc, apoyados por un avanzado laboratorio metalográfico. Se realizan grandes inversiones en centros de mecanizado de última generación para mantener una óptima calidad-productividad. La mayoría de piezas críticas (correderas, piezas de fundición, ejes de bomba, etc) se fabrican íntegramente en la propia empresa.

FIABILIDAD Una extensa gama de productos robustos y resistentes. Diseñados para rendir, contruidos para durar. Todas las gamas de productos se someten a pruebas de vida en condiciones de trabajo realistas durante el diseño y desarrollo del producto. De esta forma se asegura su perfecta adaptación a las diversas aplicaciones finales tales como tractores, carretillas elevadoras, palas cargadoras, excavadoras, grúas, volquetes, muelles de carga... Se prueba el 100% de las unidades producidas, según procedimientos internos de prueba, antes de la expedición.

CAPACIDAD 400 profesionales en plantilla. Cinco plantas de producción con una superficie cubierta de 40.000 m². Producción actual: 180.000 bombas, 300.000 cuerpos de distribuidor y 500.000 cilindros. Una red comercial de distribución extendida por más de 35 países de los 5 continentes.

HISTORY Over fifty years experience in fluid power. Supplier to international manufactures of agricultural, construction, mining, mechanical handling, machine-tool and food machinery. Main supplier to the Spanish market with rapidly increasing presence in European and world markets.

TECHNOLOGY Roquet has a large design and development department with substantial fatigue, noise, corrosion-resistance, cleanliness and testing facilities, backed by a well-equipped metallurgical laboratory.

RELIABILITY A broad range of robust products: designed to perform, built to last. All products ranges life-tested under realistic conditions during development to ensure their suitability for use in applications such as tractors, fork-lift trucks, loaders, excavators, cranes, dumpers, dock-levellers... Each and every product tested to a stringent test specification prior to shipment.

CAPABILITY 400 well trained employees. Five factories with a total floor area of 40.000m² Current production 180.000 pumps, 300.000 control valve bodies and 500.000 cylinders. Distribution network in over 35 countries.

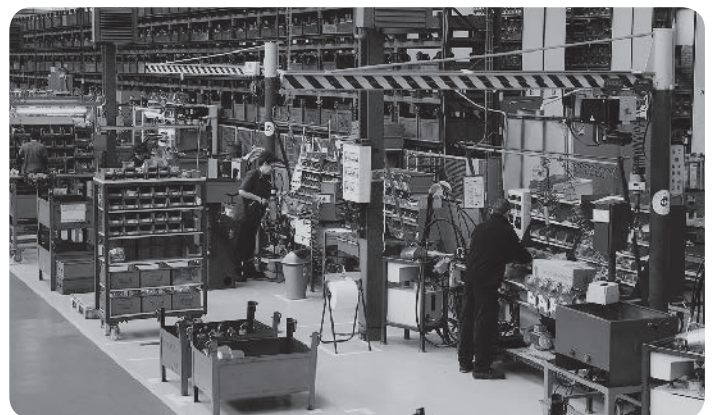
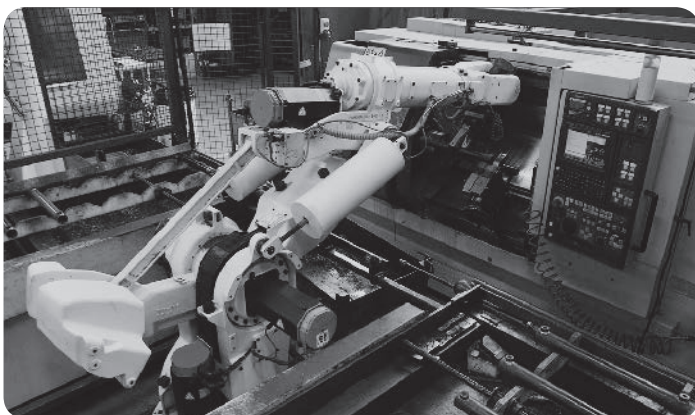

Nuestras bombas están equilibradas hidrostáticamente y provistas de reajuste lateral automático.

Se recomienda el empleo de aceite para instalaciones oleodinámicas con aditivos antiespumantes y de extrema presión.

Para obtener una larga vida, tanto del aceite como de la bomba es preciso trabajar entre una viscosidad de 20 - 80 cSt, según presiones de trabajo a una temperatura de 50° C.

Gama de temperaturas del fluido hidráulico +5° C +80° C.

El apartado de filtraje es muy importante, ya que la mayoría de averías son debidas a la suciedad del aceite. Ver datos técnicos.

La mejor forma de accionamiento es de conexión directa por medio de un acoplamiento elástico, que permite un movimiento mínimo radial y axial de 0,3 a 0,4 mm, por lo que de esta forma quedarán absorbidas todas las vibraciones del motor que tanto perjudican la buena marcha de la bomba. Los conductos de aspiración serán lo suficientemente dimensionados para que la depresión no exceda de 0,3 bars. Conexión por bridas S.A.E. o rosca G.

Sentido de giro derecha o izquierda, mirando la bomba por el lado del eje. Antes de poner por primera vez la bomba en marcha, asegurarse que el sentido de giro es el correcto.

Presentamos en el apartado de bombas dobles, varios tipos de fijación con sus ejes más normales. No obstante se podrán construir bombas dobles con las mismas fijaciones que las simples y sus ejes correspondientes.

Estas consideraciones también son validas para bombas triples y cuadruples, que podemos fabricar.

NOTA IMPORTANTE: En versión estándar la conexión es de rosca G.

Este catálogo muestra los productos en su configuración más estándar. Para diseños personalizados o especiales, deberá ponerse en contacto con ROQUETHYDRAULICS, S.L.

Las especificaciones y los datos de este catálogo no son susceptibles de interpretación. En caso de dudas, póngase en contacto con ROQUETHYDRAULICS, S.L.

ROQUETHYDRAULICS, S.L. se reserva el derecho de realizar modificaciones, actualizaciones o revisiones de este catálogo sin previo aviso.

ROQUETHYDRAULICS, S.L. no es responsable de ningún daño provocado por un uso incorrecto del producto.

Our pumps are hydrostatically balanced and have automatic lateral adjustment.

We recommend the use of the oil for oil-dynamic installations with antifoaming additives and for extreme pressure.

To obtain extended pump life it is necessary to work with oil viscosities between 20 - 80 cSt, relating to working pressure and at a temperature of 50°C.

Oil temperature range +5°C - +80°C.

Filtration is extremely important since most problems are due to oil contamination.

The most efficient drive method is by means of axial flexible coupling, with minimum 0,3 - 0,4 mm. radial and axial movement, thus reducing the effects of vibration and maintaining maximum efficiency of the pump.

The suction pipes should be large enough to ensure that cavitation does not exceed 0,3 Bar. Connection by SAE flange or threaded G.

Rotation direction: Clockwise or anti-clockwise when facing the shaft end.

Before starting the pump, make sure the direction of rotation is correct.

Double and multiple pumps are available with all shafts and flanges shown for single pumps.

IMPORTANT NOTE: Side ports threaded G are available as standard version.

This Catalogue shows the product in the most standard configuration; customized or special designs are also available, please contact to ROQUETHYDRAULICS, S.L.

The specifications and data in this catalogue are not open to any interpretation, please contact with ROQUETHYDRAULICS, S.L. in case of doubt.

ROQUETHYDRAULICS, S.L. reserves the right to modify, update or revise this catalogue without prior notice.

ROQUETHYDRAULICS, S.L. is not responsible for any damage caused by an incorrect use of the product.

Partes de una bomba / Pump parts

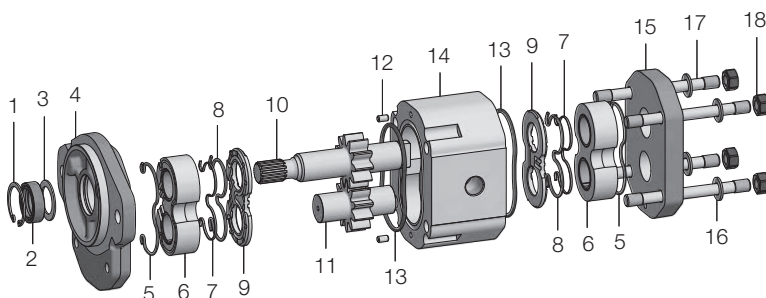

1	Anillo elástico Circlip	10	Rueda motriz Drive shaft
2	Retén aceite Oil seal	11	Rueda conducida Driven shaft
3	Aro tope retén Shaft seal end ring	12	Pasador Pin
4	Tapa frontal Front flange	13	Junta de tope Housing gasket
5	Junta apoyo cojinete O-ring	14	Cuerpo bomba Pump housing
6	Conjunto cojinete apoyo Bearing assembly	15	Tapa posterior Back cover
7	Junta antiextrusión Anti-extrusion gasket	16	Arandelas Washers
8	Junta de compensación Compensation gasket	17	Espárragos Threaded rods
9	Plaqueta de compensación Thrust plate	18	Tuercas Nuts

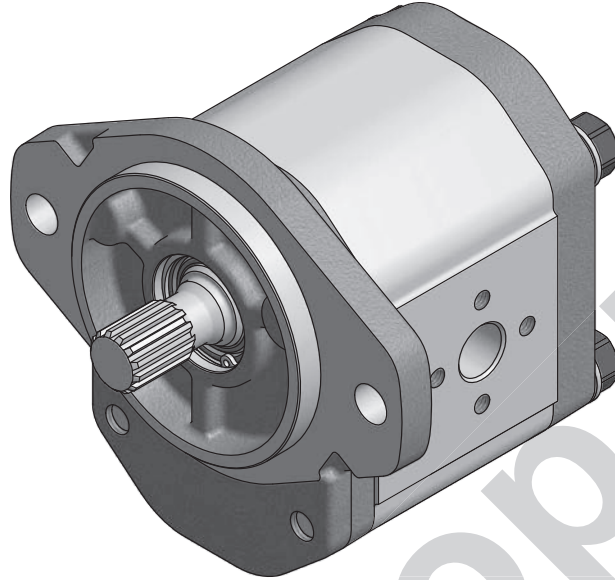

Caudal bomba <i>Pump flow rate</i>	L/min. 1500 R.P.M. (US. GPM 1500 RPM)	27 (7,1)	36 (9,5)	45 (11,9)	54 (14,3)	66 (17,4)	75 (19,8)	84 (22,2)
Cilindrada <i>Displacement</i>	cm ³ /v - cc/rev (in ³ /rev)	18 (1,1)	24 (1,46)	30 (1,83)	36 (2,2)	44 (2,69)	50 (3,05)	56 (3,42)
Presión máx. continua en <i>Cont. max. pressure</i>	bar (PSI)	250 (3625)		225 (3265)	200 (2900)	185 (2685)	175 (2540)	
Presión máx. inter 5 seg. max. <i>Intermittent max. pressure</i>	bar (PSI)	275 (3990)		250 (3625)	225 (3265)	210 (3045)	200 (2900)	
R.P.M. a presión continua <i>R.P.M. at cont. pressure</i>		2500		2300		2200		
R.P.M. máximas <i>Max. R.P.M.</i>		3000		2800		2600		
Mínimas R.P.M. según presión <i>Min. R.P.M. at given pressures</i>	100 bar (1450 PSI)	500						
	175 bar (2540 PSI)	800		700		600		
	250 bar (3625 PSI)	1500		900	-	-		
Aceite recomendado <i>Fluid to be used</i>		ISO 6743 tipo HM, HV ó HG						
Viscosidad <i>Viscosity range</i>		ISO 3448 cat. VG32-VG46						
Grado de limpieza del aceite <i>Recommended fluid cleanliness</i>		19/16 s/. ISO 4406 ó RP70H						
Temperatura de trabajo del aceite <i>Oil temperature</i>		-20°C... +80°C -4°F... +176°F						
Depresión máximo en aspiración <i>Max. suction depression</i>		< 0,3 bar						

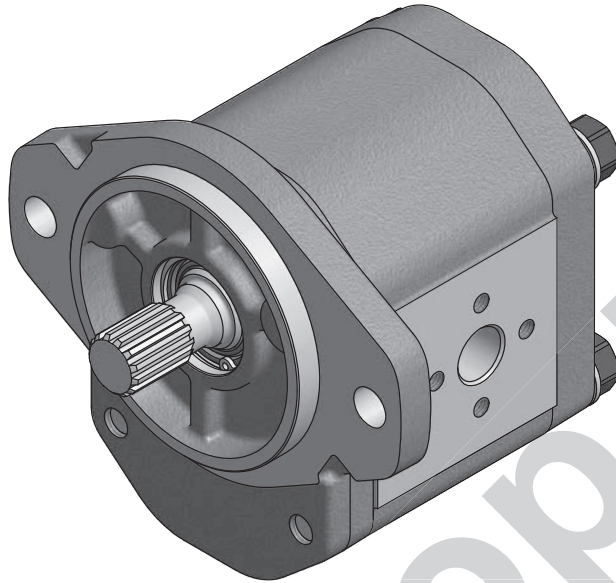

Caudal bomba <i>Pump flow rate</i>	L/min. 1500 R.P.M. (US. GPM 1500 RPM)	27 (7,1)	36 (9,5)	45 (11,9)	54 (14,3)	66 (17,4)	75 (19,8)	84 (22,2)
Cilindrada <i>Displacement</i>	cm ³ /v - cc/rev (in ³ /rev)	18 (1,1)	24 (1,46)	30 (1,83)	36 (2,2)	44 (2,69)	50 (3,05)	56 (3,42)
Presión máx. continua en <i>Cont. max. pressure</i>	bar (PSI)	300 (4350)		275 (3990)	250 (3625)	230 (3335)	215 (3120)	
Presión máx. inter 5 seg. max. <i>Intermittent max. pressure</i>	bar (PSI)	325 (4715)		300 (4350)	275 (3990)	255 (3700)	240 (3480)	
R.P.M. a presión continua <i>R.P.M. at cont. pressure</i>		2500		2300		2200		
R.P.M. máximas <i>Max. R.P.M.</i>		3000		2800		2600		
Mínimas R.P.M. según presión <i>Min. R.P.M. at given pressures</i>	100 bar (1450 PSI)	500						
	175 bar (2540 PSI)	800		700		600		
	250 bar (3625 PSI)	1500		900	-	-		
Aceite recomendado <i>Fluid to be used</i>		ISO 6743 tipo HM, HV ó HG						
Viscosidad <i>Viscosity range</i>		ISO 3448 cat. VG32-VG46						
Grado de limpieza del aceite <i>Recommended fluid cleanliness</i>		19/16 s/. ISO 4406 ó RP70H						
Temperatura de trabajo del aceite <i>Oil temperature</i>		-20°C... +80°C -4°F... +176°F						
Depresión máximo en aspiración <i>Max. suction depression</i>		< 0,3 bar						

CONEXIONES TIPO R

ROQUETHYDRAULICS, S.L. recomienda utilizar implantaciones roscadas cilíndricas: con cierre por arista de estanqueidad, junta plana o junta tórica. (Ver normas: DIN 3852, ISO1179, ISO 9974 y ISO 6149). No se recomienda utilizar otras implantaciones tipo cónicas, etc. A continuación se detallan los pares de apriete para implantaciones roscadas cilíndricas.

CONNECTION TYPES R

ROQUETHYDRAULICS, S.L. recommends to use threaded fittings with parallel threads: with sealing face, with flat seal or with o-ring seal (Standards: DIN 3852, ISO1179, ISO 9974 y ISO6149). It is not recommended to use conic type fittings, etc. Guide for tightening torques for threaded fittings with parallel threads.

PAR DE APRIETE / ASSEMBLY TORQUE

Rosca (ISO 228-1) Thread Size (ISO 228-1)	Par de apriete min. (Nm) Assembly Torque min. (Nm)	Par de apriete máx. (Nm) Assembly Torque max. (Nm)
1/8" G	20	25
1/4" G	50	55
3/8" G	80	90
1/2" G	100	100
3/4" G	200	220
1" G	380	420

ACCIONAMIENTO DE LAS BOMBAS

Deben utilizarse acoplamiento entre bomba y accionamiento que eviten la transmisión de esfuerzos tanto axiales como laterales. Las bombas en su configuración estandar no admiten este tipo de esfuerzos, causando una disminución rápida de su vida útil.

PUMP DRIVING DEVICES

It must be used a driving device to avoid the transmission of axial and radial loads to the axis of the pump. Standard flanges and pumps are not designed to handle this loads and this causes a reduction of its working life.

Gráfico de caudales, rendimientos y potencias según cilindrada
Flow, performance and power chart according to displacement

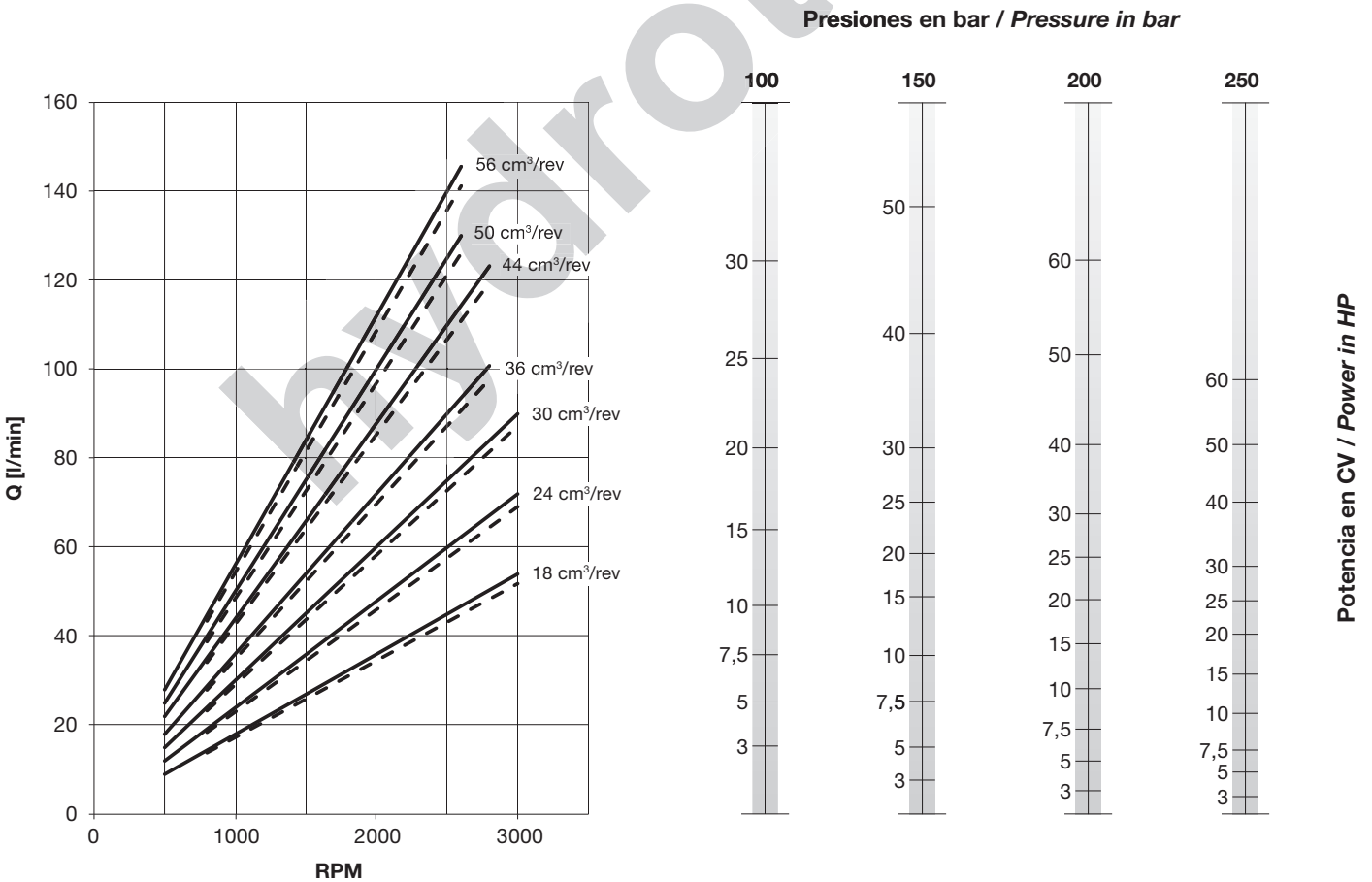

NOTA: Estos diagramas han sido obtenidos con un aceite de calidad ISO VG 46 y una temperatura de 50° C.
NOTE: The values shown in the above diagrams have been obtained using ISO VG 46 oil at 50° C.

Sistema de codificación	1	PLA	36	D	E	10	R	/	V	42	T***	-***	Coding system
-------------------------	---	-----	----	---	---	----	---	---	---	----	------	------	---------------

Tipo / Type	
1	Sin polea / Without pulley
2	Con polea / With pulley
6	Bomba con eje estriado para montaje en ZF / Pump with spline shaft for mounting onto ZF

Modelo / Model	
PLA	Simple – Cuerpo aluminio / Simple – Aluminium body
PLAN	Simple – Cuerpo fundición / Simple – Cast iron body
PLL	Múltiple / Multiple PLA+PLA
PLLN	Múltiple / Multiple PLAN+PLAN
PLD	Múltiple / Multiple PLA+L
PLDN	Múltiple / Multiple PLAN+L
PLT	Múltiple / Multiple PLA+L0
PLTN	Múltiple / Multiple PLAN+L0

Caudal bomba a 1500 rpm y 0 bar / Pump flow rate at 1500 rpm and 0 bar
Ver hoja técnica / See technical data

Sentido de giro / Rotation direction	
D	Derecha / Clockwise
I	Izquierda / Counterclockwise
R	Reversible / Reversible

Forma eje motriz / Drive shaft form
A-B-C-D-E-G-H-I-J-X-W

Tipo polea / Pulley type
P-S-T

Código / Code

Variantes con válvulas / Alternatives with valves

Válvula limitadora para baja presión / Low pressure relief valve	
VBPT**	Los caracteres ** se deben sustituir por la presión de taraje (2 dígitos). Ver presión mínima de taraje (página 27). The signs ** have to be replaced by the set pressure (2 numbers). See minimum set pressure curve (page 27). Ejemplo / Example: 1PLA36DE10R/VBPT12

Válvula limitadora / Relief valve

Modelo precintable y taraje estándar / Tamper-proof sealable model and standard set pressure	
Rango de taraje / Pressure range	
V11	Tarada a / Set at 80 bar (5-80 bar)
V12	Tarada a / Set at 160 bar (85-175 bar)
V13	Tarada a / Set at 200 bar (180-250 bar)

Modelo con precinto y taraje específico / Tamper-proof sealed model and specific set pressure	
Rango de taraje / Pressure range	
V41T***	5-80 bar
V42T***	85-175 bar
V43T***	180-250 bar

Los caracteres *** se deben sustituir por la presión de taraje (3 dígitos). Ver presión mínima de taraje (página 27).
The signs *** have to be replaced by the set pressure (3 numbers). See minimum set pressure curve (page 27).
Ejemplo / Example 1: 1PLA66DE10R/V41T060
Ejemplo / Example 2: 1PLA45DE10R/V12

Formas conexión tomas / Port connection forms

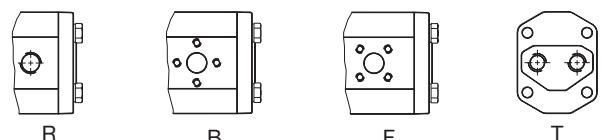

Tipo de tapa / Fixing flange

01-09-10-19-23-50

Tipos de eje motriz disponibles / Available drive shaft forms

NOTA: Las longitudes de los ejes se dan respecto la cara A de las tapas (ver página 10).
NOTE: The lengths of the shafts are given from the side A of the covers (see page 10).

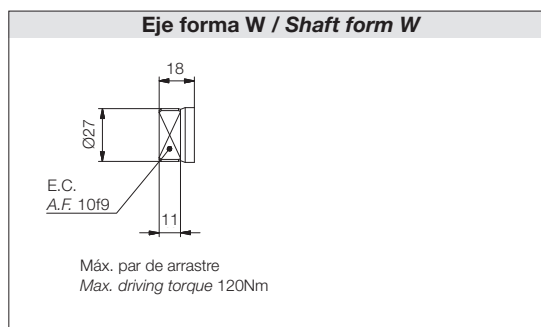
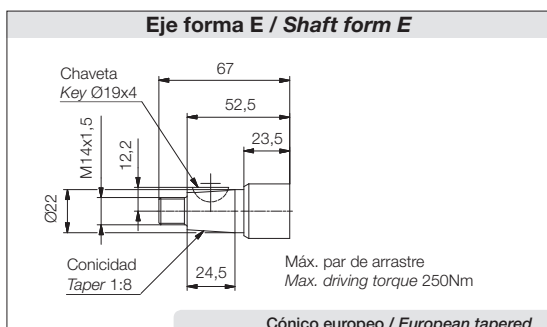
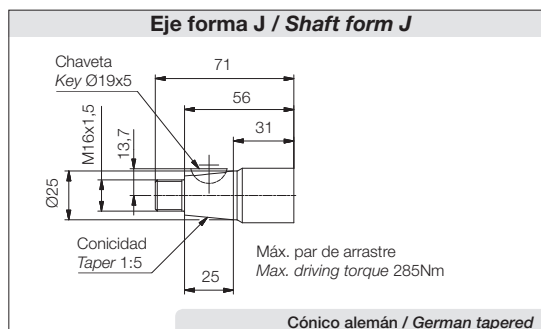
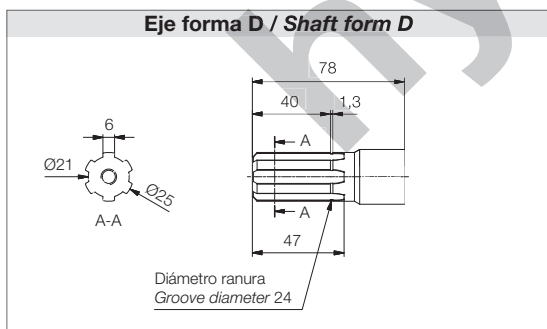
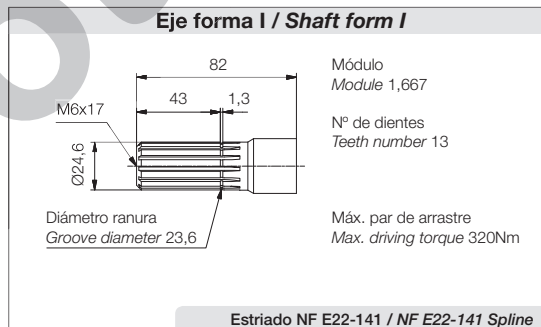
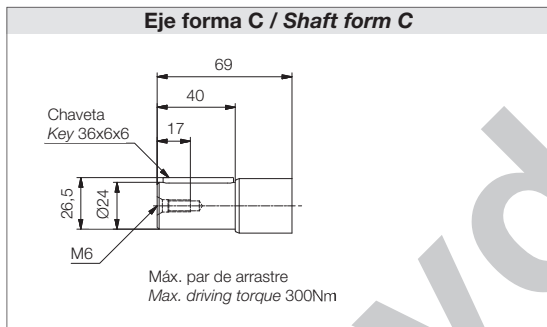
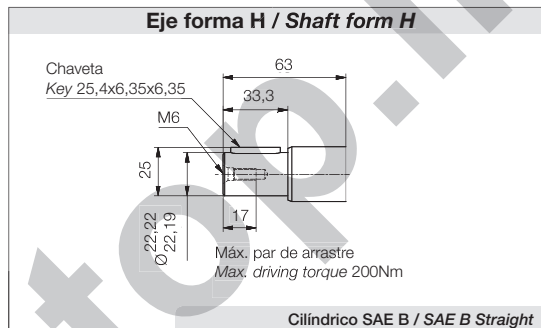
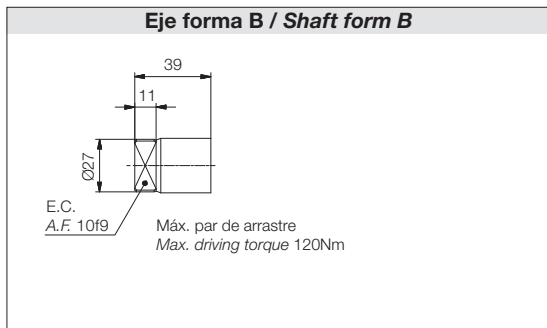
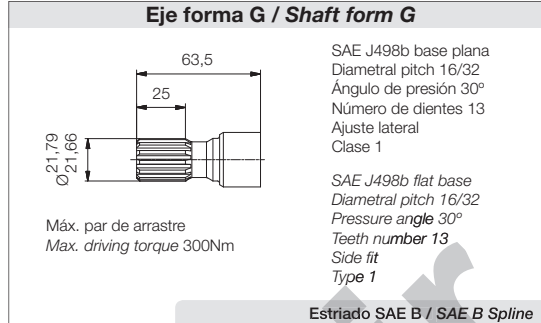
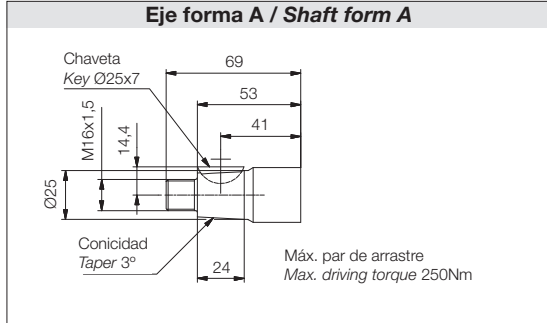

Tipos de tapas frontales disponibles / Available front flanges types

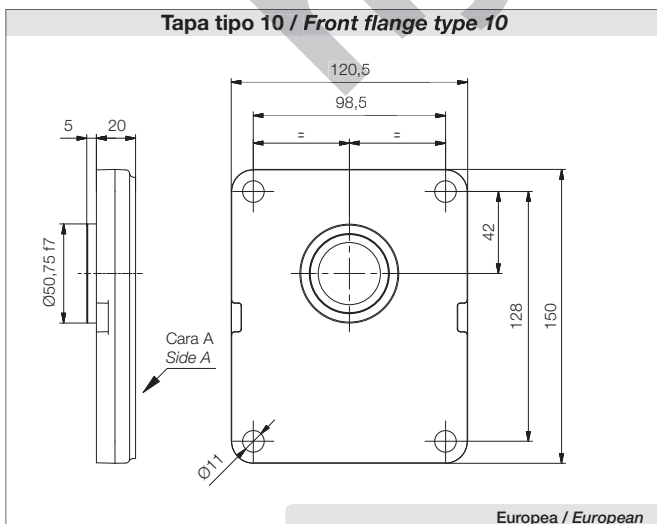
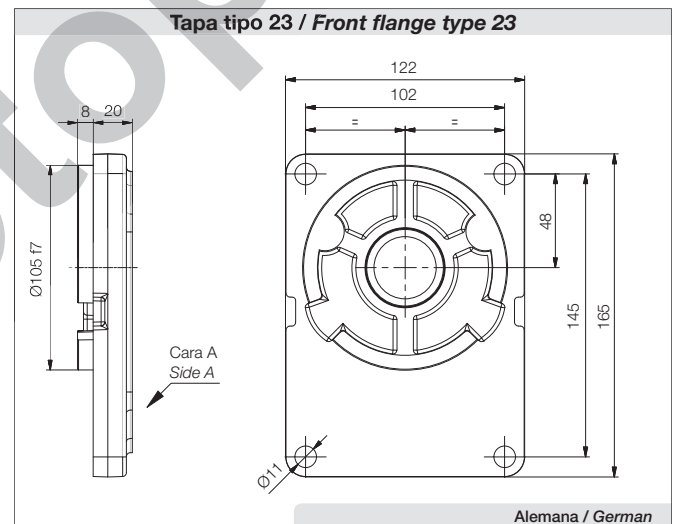
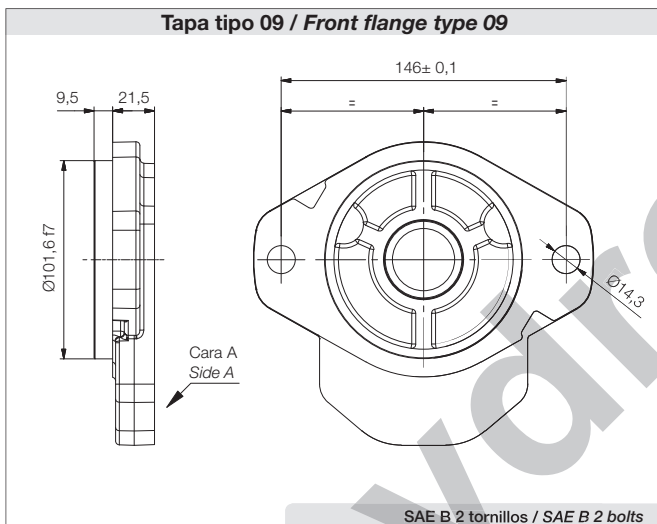
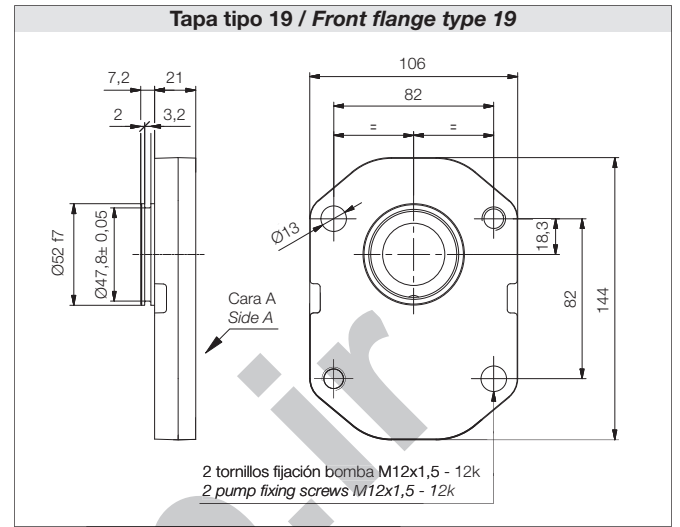
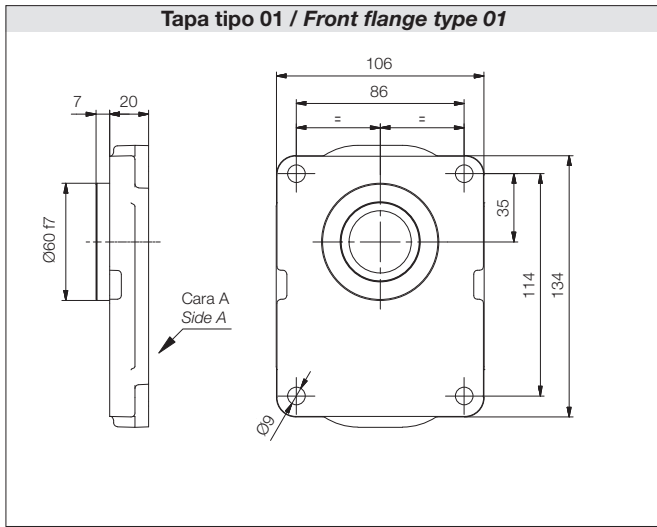

NOTA: la longitud útil del eje motriz varía en función del grosor de la tapa frontal.

NOTE: the useful length of the drive shaft varies depending on the front flange thickness.

EJEMPLO: combinación de un eje tipo C con una tapa tipo 10.

EXAMPLE: combination of a C type shaft with a 10 type front flange.

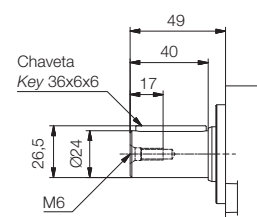

Formas de conexión de tomas disponibles / Available port connection forms

Toma forma R / Port form R

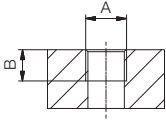

Toma forma F / Port form F

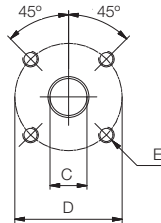

Toma forma B / Port form B

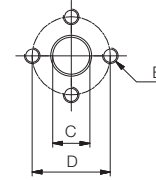

1 SENTIDO DE ROTACION / 1 ROTATION DIRECTION

Tipo de toma / Port type		Tipo / Type R		Tipo / Type F			Tipo / Type B			
Dimensiones / Dimensions		A	B	C	D	E	C	D	E	
Cilindrada bomba Pump displacement	18	Aspiración / Suction	3/4" BSP	18	26	55	M8x13	19	40	M8x13
		Presión / Pressure	1/2" BSP	16	19	55	M8x13	19	40	M8x13
	24	Aspiración / Suction	3/4" BSP	18	26	55	M8x13	26	51	M10x13
		Presión / Pressure	1/2" BSP	16	19	55	M8x13	19	40	M8x13
	30	Aspiración / Suction	3/4" BSP	18	26	55	M8x13	26	51	M10x13
		Presión / Pressure	1/2" BSP	16	19	55	M8x13	19	40	M8x13
	36	Aspiración / Suction	3/4" BSP	18	26	55	M8x13	26	51	M10x13
		Presión / Pressure	1/2" BSP	16	19	55	M8x13	19	40	M8x13
	44	Aspiración / Suction	1" BSP	18,5	26	55	M8x13	26	51	M10x13
		Presión / Pressure	3/4" BSP	18	19	55	M8x13	19	40	M8x13
	50	Aspiración / Suction	1" BSP	18,5	26	55	M8x13	26	51	M10x13
		Presión / Pressure	3/4" BSP	18	19	55	M8x13	19	40	M8x13
56	Aspiración / Suction	1" BSP	18,5	26	55	M8x13	26	51	M10x13	
	Presión / Pressure	3/4" BSP	18	19	55	M8x13	19	40	M8x13	

REVERSIBLE / BIDIRECTIONAL

Tipo de toma / Port type		Tipo / Type R		Tipo / Type F			Tipo / Type B			
Dimensiones / Dimensions		A	B	C	D	E	C	D	E	
Cilindrada bomba Pump displacement	18	Aspiración y presión Suction and Pressure	3/4" BSP	18	26	55	M8x13	26	51	M10x13
	24	Aspiración y presión Suction and Pressure	3/4" BSP	18	26	55	M8x13	26	51	M10x13
	30	Aspiración y presión Suction and Pressure	3/4" BSP	18	26	55	M8x13	26	51	M10x13
	36	Aspiración y presión Suction and Pressure	3/4" BSP	18	26	55	M8x13	26	51	M10x13
	44	Aspiración y presión Suction and Pressure	1" BSP	18,5	26	55	M8x13	26	51	M10x13
	50	Aspiración y presión Suction and Pressure	1" BSP	18,5	26	55	M8x13	26	51	M10x13
	56	Aspiración y presión Suction and Pressure	1" BSP	18,5	26	55	M8x13	26	51	M10x13

Tapa tipo 01 / Front flange type 01



Eje forma A / Shaft form A

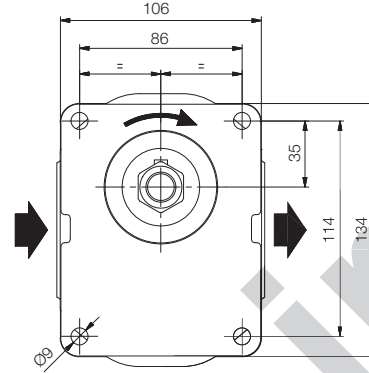
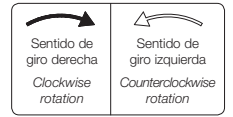
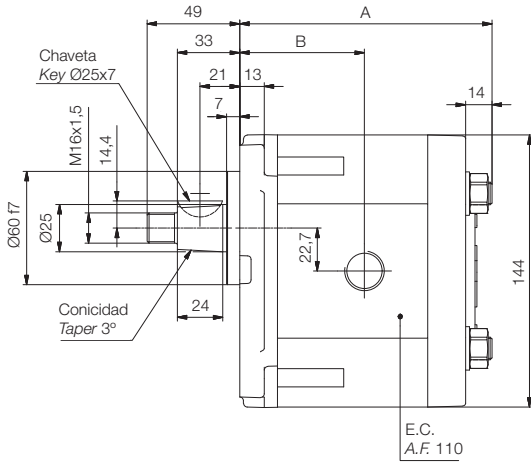

Eje forma C / Shaft form C

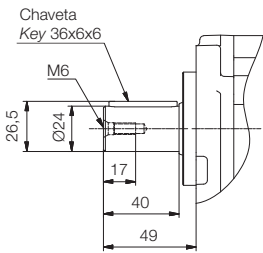

Eje forma D / Shaft form D

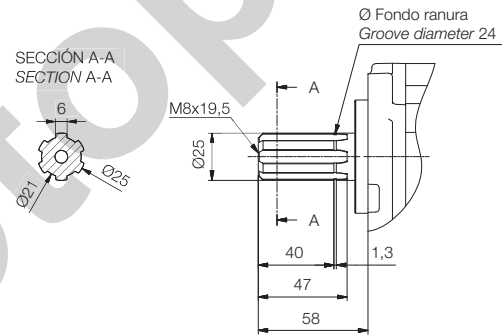

Eje forma I / Shaft form I

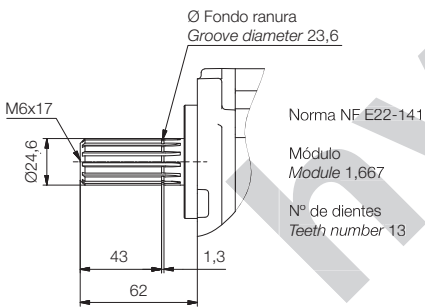

Eje forma B / Shaft form B

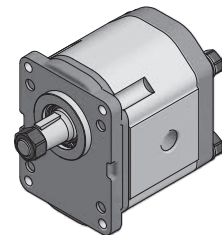
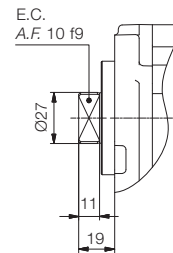

Referencia Reference	Cilindrada cm ³ /rev Displacement cm ³ /rev	A	B	PLA - Peso kg PLA - Weight kg	PLAN - Peso kg PLAN - Weight kg
1*27D▲01R	18	128,5	66	7,8	10,7
1*36D▲01R	24	133,5		8,1	11,1
1*45D▲01R	30	138,5		8,3	11,5
1*54D▲01R	36	143,5		8,6	11,9
1*66D▲01R	44	150,0		8,9	12,5
1*75D▲01R	50	154,5	71	9,2	12,9
1*84D▲01R	56	159,5		9,4	13,3

* PLA Cuerpo de aluminio / Aluminium body. PLAN Cuerpo de fundición / Cast iron body. ▲ Forma de eje / Shaft form.

NOTA: Para dimensiones y tipos de tomas disponibles de bombas de giro derecha (D), izquierda (I) o reversible (R), consultar página 11.
NOTE: For dimensions and available port types of clockwise (D), counterclockwise (I) or reversible (R) rotation pumps, see page 11.

Tapa tipo 10 / Front flange type 10

Eje forma E / Shaft form E

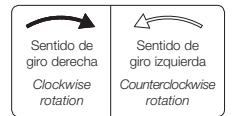
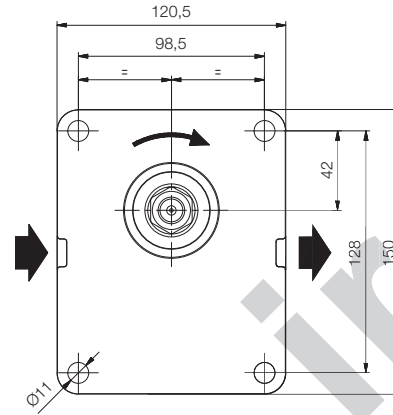
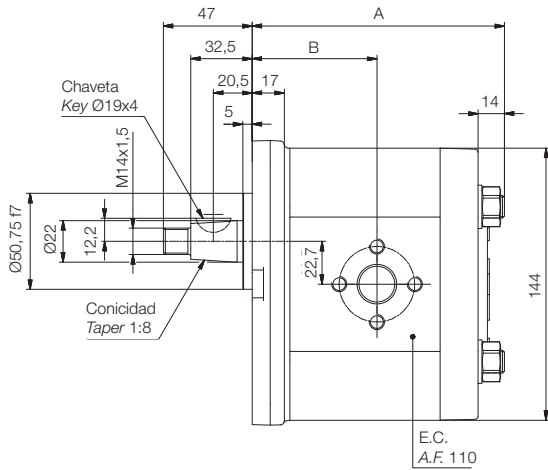

Eje forma C / Shaft form C

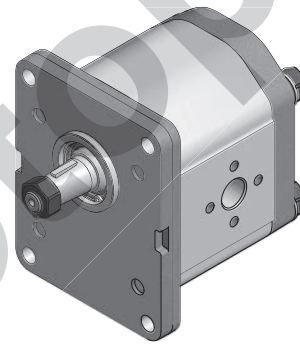
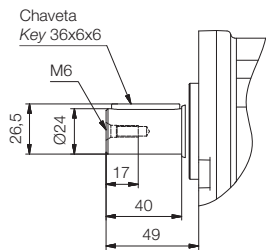

Referencia Reference	Cilindrada cm ³ /rev Displacement cm ³ /rev	A	B	PLA - Peso kg PLA - Weight kg	PLAN - Peso kg PLAN - Weight kg
1*27D▲10B	18	128,5	58	8,1	11,0
1*36D▲10B	24	133,5	66	8,4	11,4
1*45D▲10B	30	138,5	71	8,6	11,8
1*54D▲10B	36	143,5		8,9	12,3
1*66D▲10B	44	150,0		9,2	12,8
1*75D▲10B	50	154,5		9,5	13,2
1*84D▲10B	56	159,5		9,8	13,6

* PLA Cuerpo de aluminio / Aluminium body. PLAN Cuerpo de fundición / Cast iron body. ▲ Forma de eje / Shaft form.

NOTA: Para dimensiones y tipos de tomas disponibles de bombas de giro derecha (D), izquierda (I) o reversible (R), consultar página 11.
NOTE: For dimensions and available port types of clockwise (D), counterclockwise (I) or reversible (R) rotation pumps, see page 11.

Tapa tipo 23 / Front flange type 23

Eje forma J / Shaft form J

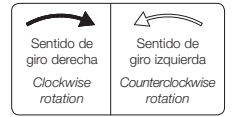
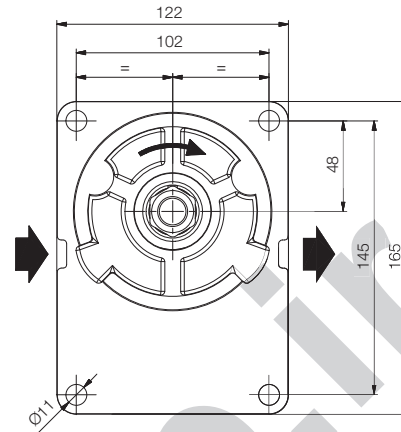
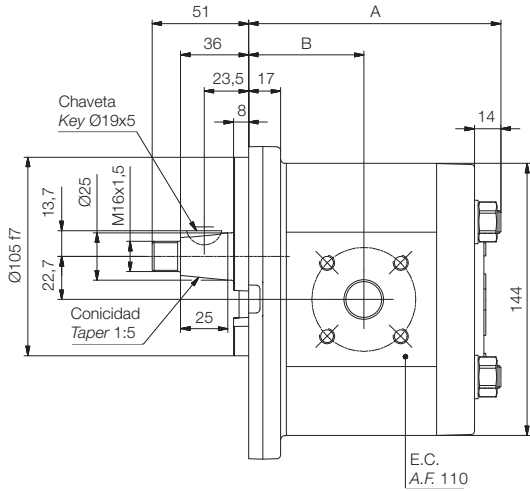

Eje forma C / Shaft form C

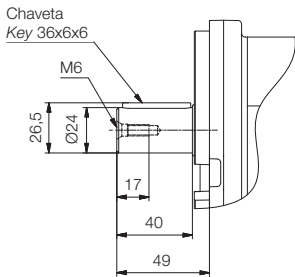

Eje forma G / Shaft form G

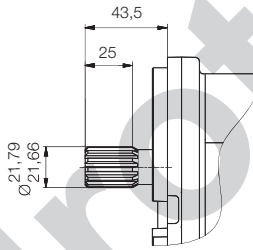

SAE J498b base plana
Diametral pitch 16/32
Ángulo de presión 30°
Número de dientes 13
Ajuste lateral
Clase 1

SAE J498b flat base
Diametral pitch 16/32
Pressure angle 30°
Teeth number 13
Side fit
Type 1

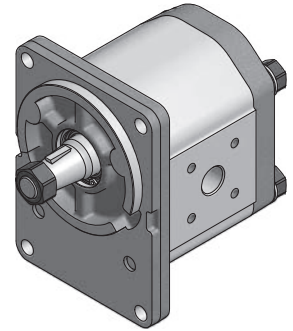

Referencia Reference	Cilindrada cm ³ /rev Displacement cm ³ /rev	A	B	PLA - Peso kg PLA - Weight kg	PLAN - Peso kg PLAN - Weight kg
1*27D▲23F	18	128,5	61	8,4	11,3
1*36D▲23F	24	133,5		8,7	11,7
1*45D▲23F	30	138,5	64,5	9,0	12,1
1*54D▲23F	36	143,5	66,5	9,2	12,6
1*66D▲23F	44	150,0	69,5	9,6	13,2
1*75D▲23F	50	154,5	73	9,8	13,6
1*84D▲23F	56	159,5	77	10,1	13,9

* PLA Cuerpo de aluminio / Aluminium body. PLAN Cuerpo de fundición / Cast iron body. ▲ Forma de eje / Shaft form.

NOTA: Para dimensiones y tipos de tomas disponibles de bombas de giro derecha (D), izquierda (I) o reversible (R), consultar página 11.
NOTE: For dimensions and available port types of clockwise (D), counterclockwise (I) or reversible (R) rotation pumps, see page 11.

Tapa tipo 19 / Front flange type 19

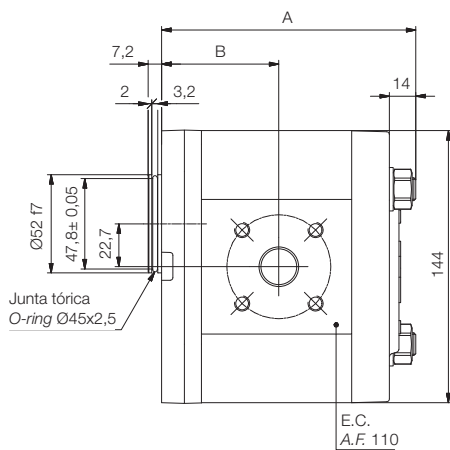

Par de apriete tornillos fijación bomba
Pump fixing screws torque 110 Nm

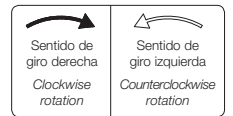
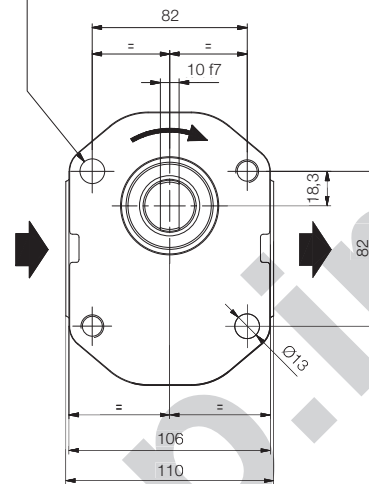

Eje forma W / Shaft form W

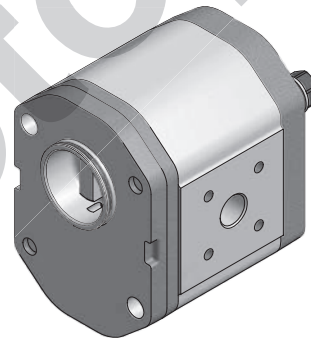
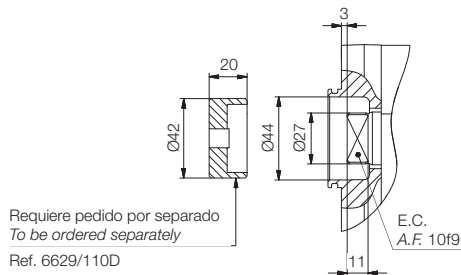

Referencia Reference	Cilindrada cm ³ /rev Displacement cm ³ /rev	A	B	PLA - Peso kg PLA - Weight kg	PLAN - Peso kg PLAN - Weight kg
1*27DW19F	18	129,5	62	7,5	10,4
1*36DW19F	24	134,5		7,7	10,7
1*45DW19F	30	139,5	65,5	8,0	11,2
1*54DW19F	36	144,5	67,5	8,3	11,6
1*66DW19F	44	151,0	70,5	8,6	12,2
1*75DW19F	50	155,5	74	8,9	12,6
1*84DW19F	56	160,5	78	9,1	13,0

* PLA Cuerpo de aluminio / Aluminium body. PLAN Cuerpo de fundición / Cast iron body.

NOTA: Para dimensiones y tipos de tomas disponibles de bombas de giro derecha (D), izquierda (I) o reversible (R), consultar página 11.
NOTE: For dimensions and available port types of clockwise (D), counterclockwise (I) or reversible (R) rotation pumps, see page 11.

Tapa tipo 09 / Front flange type 09

Eje forma G / Shaft form G

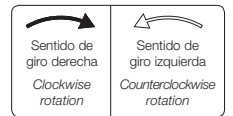
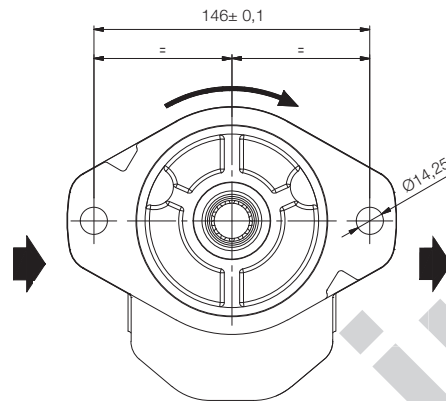
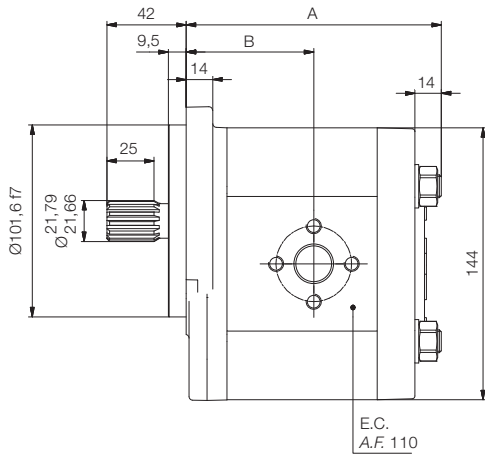

SAE J498b base plana
Diametral pitch 16/32
Ángulo de presión 30°
Número de dientes 13
Ajuste lateral
Clase 1

SAE J498b flat base
Diametral pitch 16/32
Pressure angle 30°
Teeth number 13
Side fit
Type 1

Eje forma H / Shaft form H

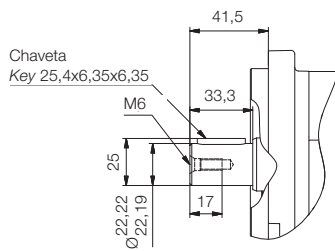

Eje forma C / Shaft form C

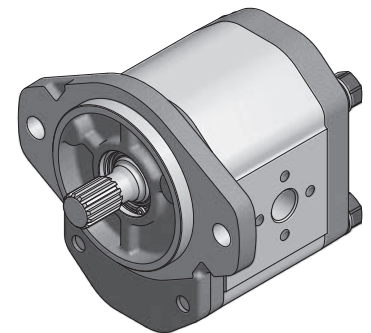
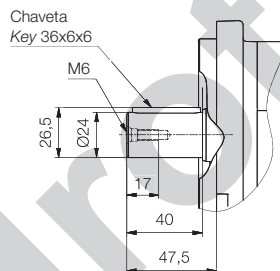

Referencia Reference	Cilindrada cm ³ /rev Displacement cm ³ /rev	A	B	PLA - Peso kg PLA - Weight kg	PLAN - Peso kg PLAN - Weight kg
1*27D▲09B	18	130,0	59,5	8,2	11,1
1*36D▲09B	24	135,0	67,5	8,5	11,5
1*45D▲09B	30	140,0	72,5	8,7	11,9
1*54D▲09B	36	145,0		9,0	12,3
1*66D▲09B	44	151,5		9,3	12,9
1*75D▲09B	50	156,0		9,6	13,3
1*84D▲09B	56	161,0		9,9	13,7

* PLA Cuerpo de aluminio / Aluminium body. PLAN Cuerpo de fundición / Cast iron body. ▲ Forma de eje / Shaft form.

NOTA: Para dimensiones y tipos de tomas disponibles de bombas de giro derecha (D), izquierda (I) o reversible (R), consultar página 11.
NOTE: For dimensions and available port types of clockwise (D), counterclockwise (I) or reversible (R) rotation pumps, see page 11.

Tapa tipo 10 / Front flange type 10

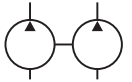

Eje forma E / Shaft form E

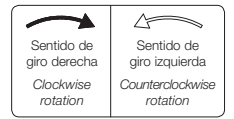
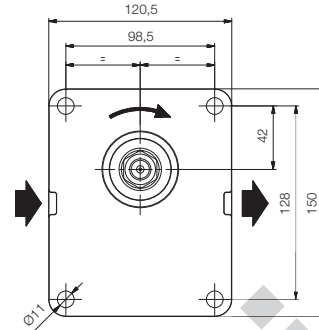
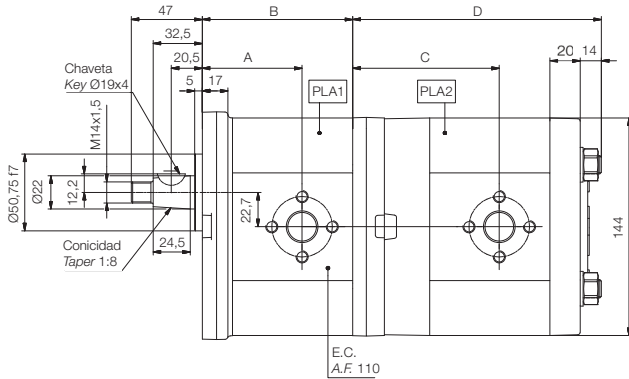

Eje forma C / Shaft form C

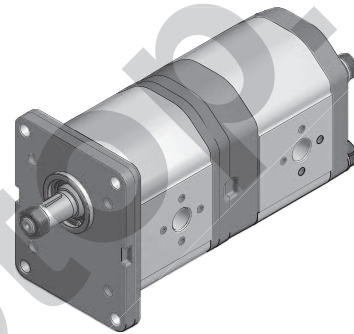
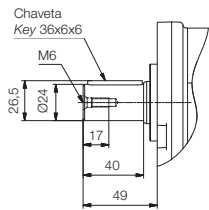

Para montajes de bombas de más de dos etapas, consultar con el departamento comercial. Máximo par de arrastre entre bombas 120 Nm.
For more than two stages pump assemblies, contact the sales department. Maximum driving torque between stages 120 Nm.

La tabla siguiente hace referencia a la etapa frontal (PLA1) de la bomba múltiple PLL.
The following table refers to the front stage (PLA1) of the PLL multiple pump.

Referencia Reference	Cilindrada Displacement cm ³ /rev	A	B	PLA - Peso kg PLA - Weight kg	PLAN - Peso kg PLAN - Weight kg
1*27-■D▲10B	18	58	94,5	8,3	11,2
1*36-■D▲10B	24	66	99,5	8,6	11,6
1*45-■D▲10B	30	71	104,5	8,9	12,0
1*54-■D▲10B	36	71	109,5	9,1	12,5
1*66-■D▲10B	44	71	116,0	9,5	13,1
1*75-■D▲10B	50	71	121,0	9,7	13,4
1*84-■D▲10B	56	71	126,0	10,0	13,8

* PLL Cuerpo de aluminio / Aluminium body. PLLN Cuerpo de fundición / Cast iron body.
■ Caudal etapa posterior (PLA2). Ver tabla / Rear stage flow (PLA2). See table.
▲ Forma de eje / Shaft form.

La tabla siguiente hace referencia a la etapa posterior (PLA2) de la bomba múltiple PLL.
The following table refers to the rear stage (PLA2) of the PLL multiple pump.

■	Cilindrada Displacement cm ³ /rev	C	D	PLA - Peso kg PLA - Weight kg	PLAN - Peso kg PLAN - Weight kg
27	18	108,9	159,4	8,3	11,2
36	24	116,9	164,4	8,6	11,6
45	30	121,9	169,4	8,9	12,0
54	36	121,9	174,4	9,1	12,5
66	44	121,9	180,9	9,5	13,1
75	50	121,9	185,9	9,7	13,4
84	56	121,9	190,9	10,0	13,8

Ejemplo referencia comercial bomba PLL Part number example PLL pump

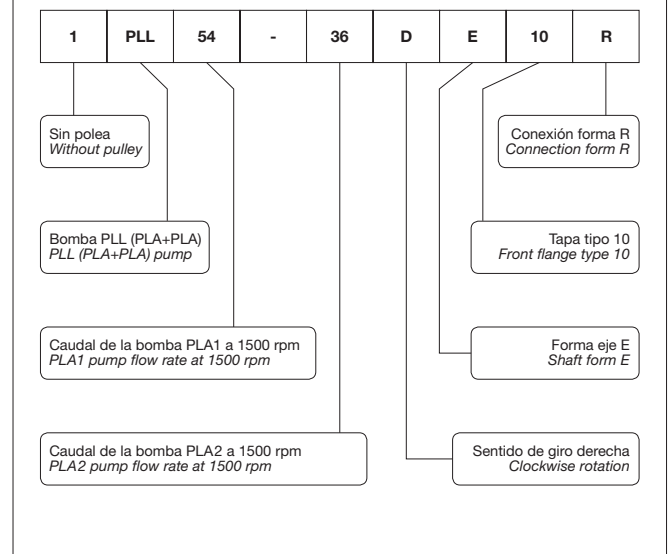

NOTA: Para dimensiones y tipos de tomas disponibles de bombas de giro derecha (D), izquierda (I) o reversible (R), consultar página 11.
NOTE: For dimensions and available port types of clockwise (D), counterclockwise (I) or reversible (R) rotation pumps, see page 11.

Tapa tipo 10 / Front flange type 10

Eje forma E / Shaft form E

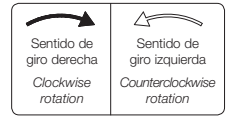
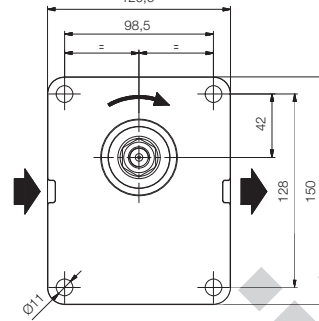
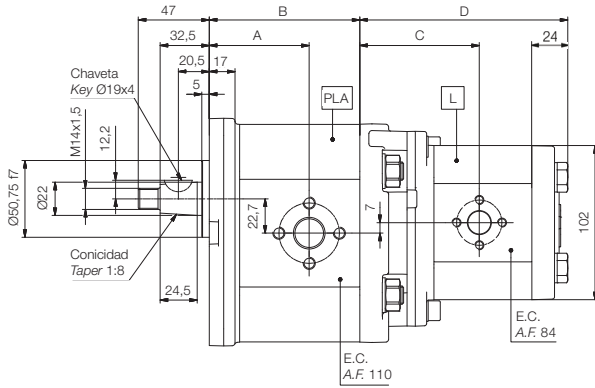

Eje forma C / Shaft form C

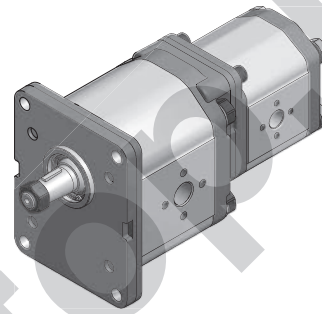
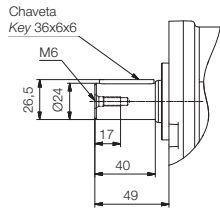

Para montajes de bombas de más de dos etapas, consultar con el departamento comercial. Máximo par de arrastre entre bombas 65 Nm.
For more than two stages pump assemblies, contact the sales department. Maximum driving torque between stages 65 Nm.

La tabla siguiente hace referencia a la etapa frontal (PLA) de la bomba múltiple PLD.
The following table refers to the front stage (PLA) of the PLD multiple pump.

Referencia Reference	Cilindrada Displacement cm ³ /rev	A	B	PLA - Peso kg PLA - Weight kg	PLAN - Peso kg PLAN - Weight kg
1*27-■D▲10B	18	58	94,5	8,3	11,2
1*36-■D▲10B	24	66	99,5	8,6	11,6
1*45-■D▲10B	30	71	104,5	8,9	12,0
1*54-■D▲10B	36	71	109,5	9,1	12,5
1*66-■D▲10B	44	71	116,0	9,5	13,1
1*75-■D▲10B	50	71	121,0	9,7	13,4
1*84-■D▲10B	56	71	126,0	10,0	13,8

* PLD Cuerpo de aluminio / Aluminium body. PLDN Cuerpo de fundición / Cast iron body.
■ Caudal etapa posterior (L). Ver tabla / Rear stage flow (L). See table.
▲ Forma de eje / Shaft form.

La tabla siguiente hace referencia a la etapa posterior (L) de la bomba múltiple PLD.
The following table refers to the rear stage (L) of the PLD multiple pump.

■	Cilindrada Displacement cm ³ /rev	C	D	L - Peso kg L - Weight kg
6	4	72,5	119,6	3,2
9	6	72,5	124,1	3,3
12	8	74,6	127,3	3,4
16	10,6	79,0	131,8	3,5
18	12	79,0	133,3	3,6
22	14,6	79,0	137,6	3,7
24	16	79,0	139,8	3,8
27	18	79,0	142,3	3,9
35	23,3	86,5	151,3	4,1
40	26,6	94,0	155,3	4,3

Ejemplo referencia comercial bomba PLD Part number example PLD pump

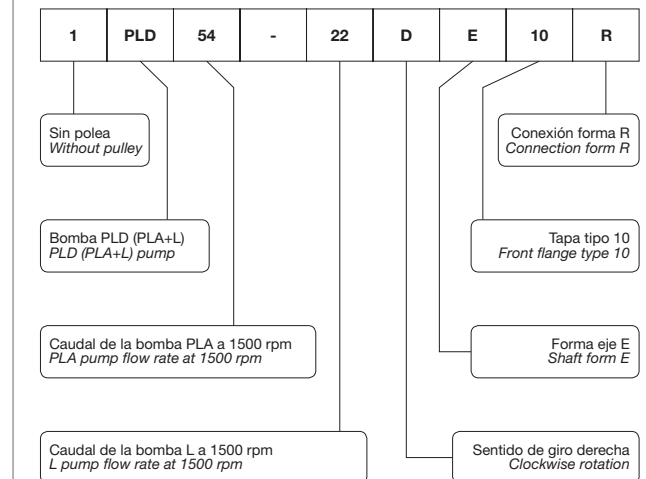

NOTAS

- Bomba PLA: para dimensiones y tipos de tomas disponibles de bombas de giro derecha (D), izquierda (I) o reversible (R), consultar página 11.
- Bomba L: para dimensiones y tipos de tomas disponibles consultar catálogo L.

NOTES

- PLA pump: for dimensions and available port types of clockwise (D), counterclockwise (I) or reversible (R) rotation pumps, see page 11.
- L pump: for dimensions and port types see L catalog.

Tapa tipo 10 / Front flange type 10

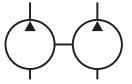

Eje forma E / Shaft form E

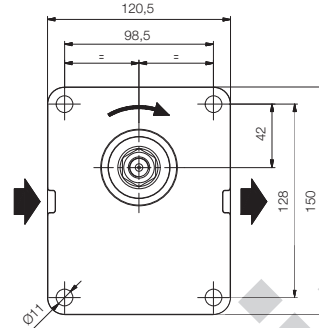
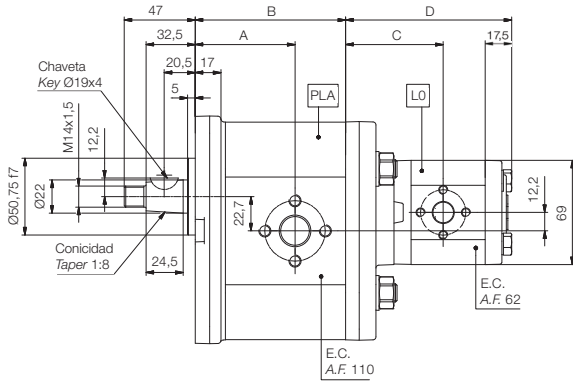

Eje forma C / Shaft form C

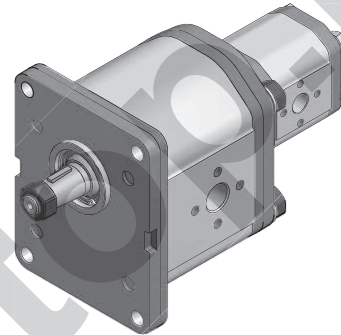
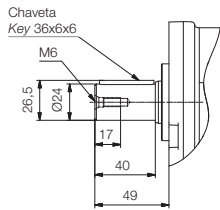

Para montajes de bombas de más de dos etapas, consultar con el departamento comercial. Máximo par de arrastre entre bombas 25 Nm.
For more than two stages pump assemblies, contact the sales department. Maximum driving torque between stages 25 Nm.

La tabla siguiente hace referencia a la etapa frontal (PLA) de la bomba múltiple PLT.
The following table refers to the front stage (PLA) of the PLT multiple pump.

Referencia Reference	Cilindrada Displacement cm ³ /rev	A	B	PLA - Peso kg PLA - Weight kg	PLAN - Peso kg PLAN - Weight kg
1*27-■D▲10B	18	58	94,5	8,3	11,2
1*36-■D▲10B	24	66	99,5	8,6	11,6
1*45-■D▲10B	30	71	104,5	8,9	12,0
1*54-■D▲10B	36	71	109,5	9,1	12,5
1*66-■D▲10B	44	71	116,0	9,5	13,1
1*75-■D▲10B	50	71	121,0	9,7	13,4
1*84-■D▲10B	56	71	126,0	10,0	13,8

* PLT Cuerpo de aluminio / Aluminium body. PLTN Cuerpo de fundición / Cast iron body.
■ Caudal etapa posterior (L0). Ver tabla / Rear stage flow (L0). See table.
▲ Forma de eje / Shaft form.

La tabla siguiente hace referencia a la etapa posterior (L0) de la bomba múltiple PLT.
The following table refers to the rear stage (L0) of the PLT multiple pump.

■	Cilindrada Displacement cm ³ /rev	C	D	L0 - Peso kg L0 - Weight kg
1,5	1	61,0	97,8	1,2
3	2	61,0	102,8	1,3
5	3,3	64,5	109,8	1,4
7,5	5	67,5	117,3	1,5
10	6,6	72,8	126,8	1,6

Ejemplo referencia comercial bomba PLT Part number example PLT pump

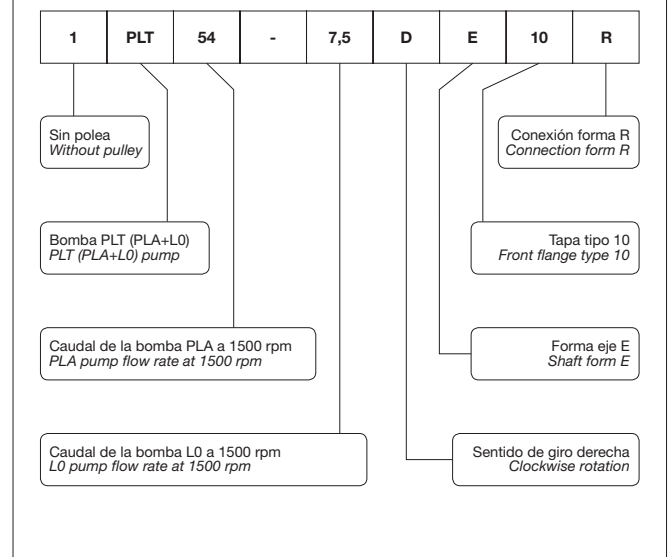

NOTAS

- Bomba PLA: para dimensiones y tipos de tomas disponibles de bombas de giro derecha (D), izquierda (I) o reversible (R), consultar página 11.
- Bomba L0: para dimensiones y tipos de tomas disponibles consultar catálogo L0.

NOTES

- PLA pump: for dimensions and available port types of clockwise (D), counterclockwise (I) or reversible (R) rotation pumps, see page 11.
- L0 pump: for dimensions and port types see L0 catalog.

Conexión con tomas T
Port connection form T



Tapa trasera para bombas reversibles
Back cover for reversible pumps

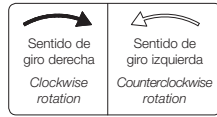
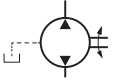

Tapa posterior para bombas con tomas traseras
Back cover with rear ports

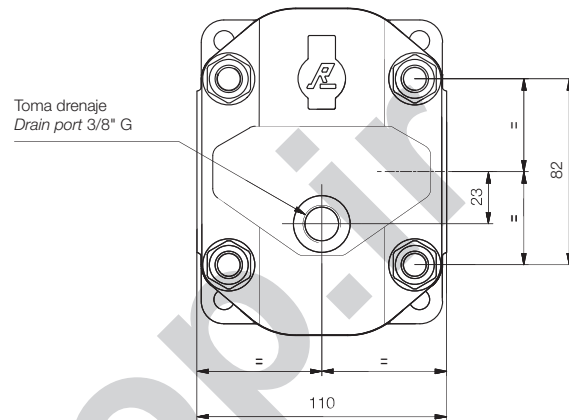
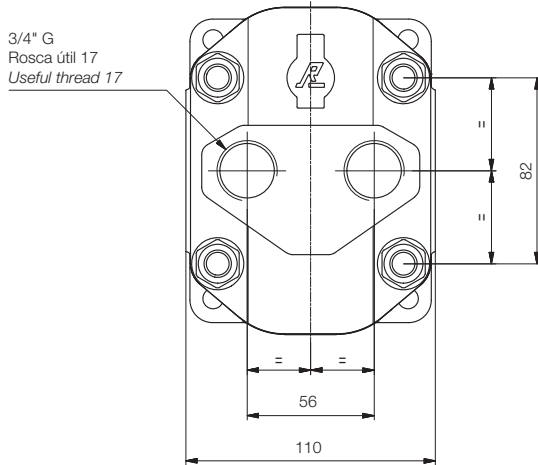

Tipos de polea / Types of pulley

Tipo P / Type P

Correa tipo C
Belt type C

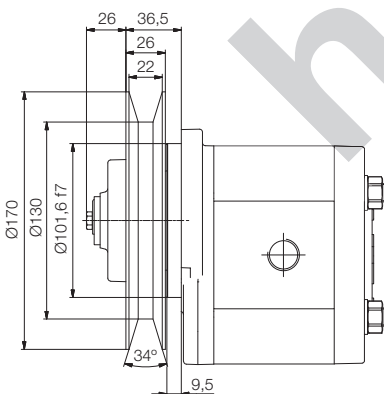

Tipo S / Type S

Correa tipo B
Belt type B

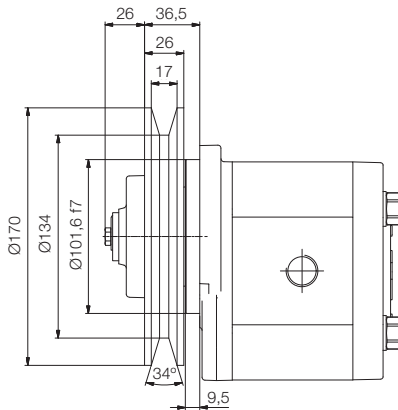

Tipo T / Type T

Correa tipo B
Belt type B

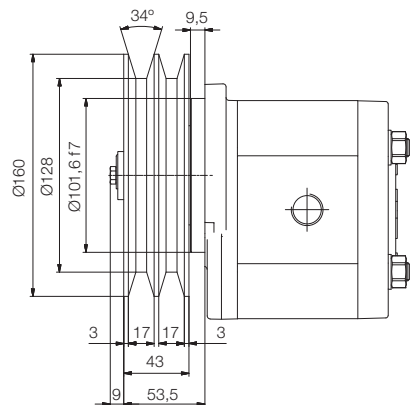

NOTA: Opción solo disponible con tapa tipo 09. Para medidas de fijación bomba ver página 10.
NOTE: Option only available with flange type 09. For pump fixing dimensions see page 10.

Tapa tipo 50 / Front flange type 50

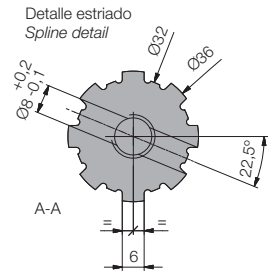
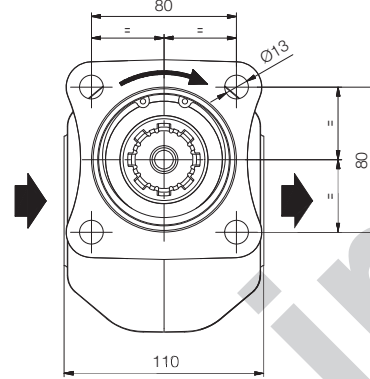
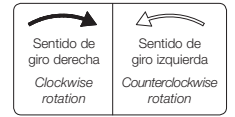
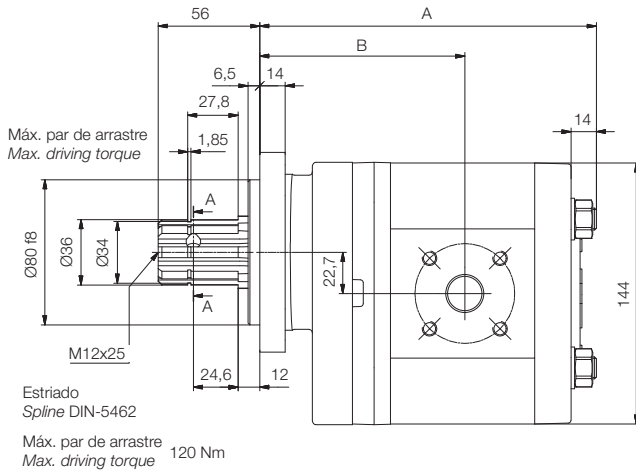

Lado aspiración
Suction side

Conexión tipo F
Connection type F

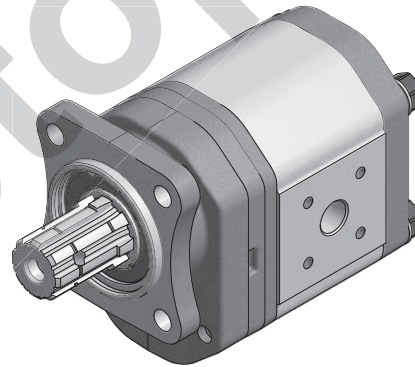
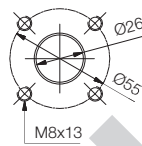

Referencia Reference	Cilindrada cm ³ /rev Displacement cm ³ /rev	A	B	PLA - Peso kg PLA - Weight kg	PLAN - Peso kg PLAN - Weight kg
6*27DX50F	18	180,5	113	11,5	14,3
6*36DX50F	24	185,5		11,7	14,7
6*45DX50F	30	190,5	116,5	12,0	15,2
6*54DX50F	36	195,5	118,5	12,3	15,6
6*66DX50F	44	202,0	121,5	12,6	16,2
6*75DX50F	50	206,5	125	12,9	16,6
6*84DX50F	56	211,5	129	13,1	17,0

* PLA Cuerpo de aluminio / Aluminium body. PLAN Cuerpo de fundición / Cast iron body.

NOTA: Para dimensiones y tipos de tomas disponibles de bombas de giro derecha (D), izquierda (I) o reversible (R), consultar página 11.
NOTE: For dimensions and available port types of clockwise (D), counterclockwise (I) or reversible (R) rotation pumps, see page 11.

VBP- Válvula limitadora para baja presión

Low pressure relief valve

Curva presión mínima taraje /
Minimum setting pressure curve

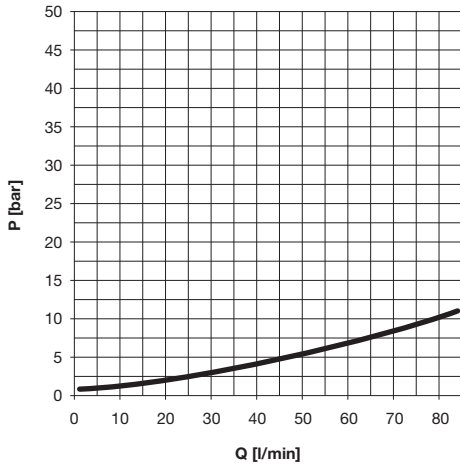

Presión máxima de taraje: 20 bar.
Maximum set pressure: 20 bar.

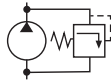

V- Válvula limitadora

Relief valve

Diagrama presión-caudal válvula limitadora según rango de taraje /
Relief valve pressure-flow diagram depending on pressure range

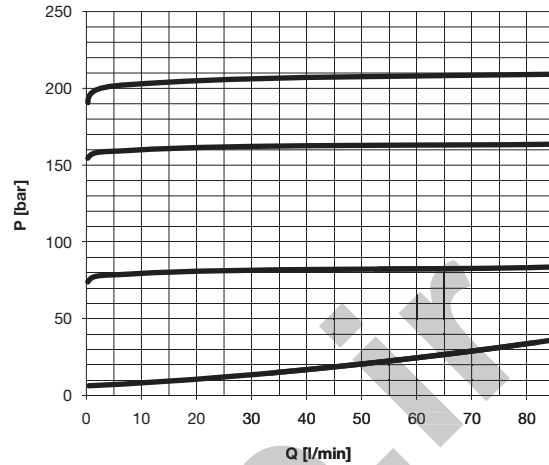

V13 - V43 (180-250 bar)
Tarada a / Set at 200 bar

V12 - V42 (85-175 bar)
Tarada a / Set at 160 bar

V11 - V41 (5-80 bar)
Tarada a / Set at 80 bar

Curva presión mínima
Minimal pressure curve

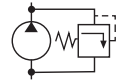

NOTA: Estos diagramas han sido obtenidos con un aceite de viscosidad cinemática de 32 cSt / **NOTE:** The values shown in the above diagram have been obtained using a 32 cSt kinematic viscosity oil.

Tapa tipo 10 / Front flange type 10

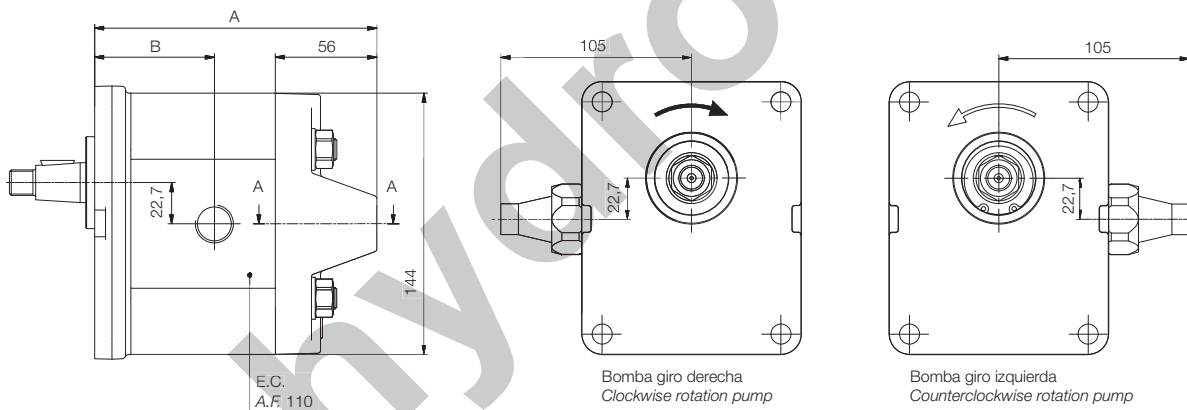

Referencia Reference	Cilindrada cm ³ /rev Displacement cm ³ /rev	A	B	PLA - Peso kg PLA - Weight kg	PLAN - Peso kg PLAN - Weight kg
1*27DE10R/V■	18	150,5	66	9,2	12,0
1*36DE10R/V■	24	155,5		9,4	12,4
1*45DE10R/V■	30	160,5		9,7	12,8
1*54DE10R/V■	36	165,5	71	9,9	13,3
1*66DE10R/V■	44	172		10,3	13,9
1*75DE10R/V■	50	176,5		10,6	14,3
1*84DE10R/V■	56	181,5		10,8	14,7

* PLA Cuerpo de aluminio / Aluminium body. PLAN Cuerpo de fundición / Cast iron body. — ■ Modelo de válvula limitadora (ver página 8) / Relief valve model (see page 8).

NOTA: Esta bomba con válvula limitadora está disponible con cualquiera de las tapas y ejes que se representan en este catálogo, pero solo con cuerpos con tomas R. Consultar con el departamento comercial para otras opciones.

NOTE: This pump with relief valve is available with any fixing flange and shaft form shown in this catalogue, but only with pump housings with R ports. For other options, contact the sales department.

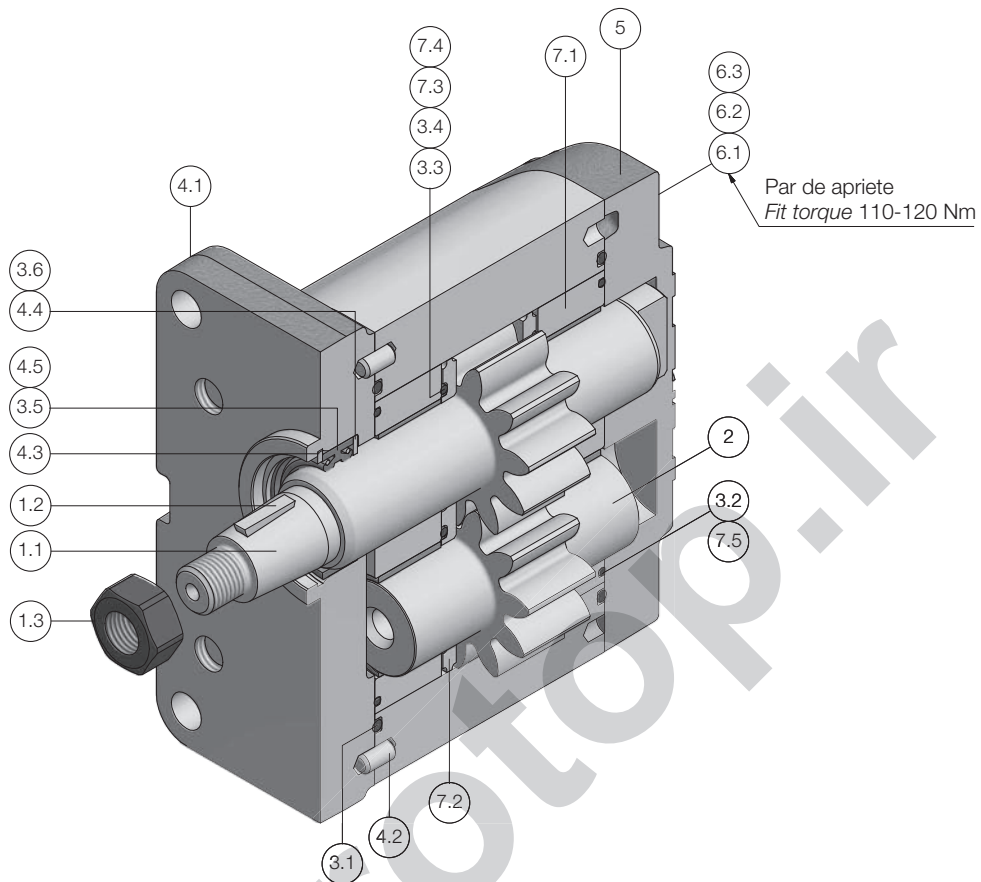

Nº de kit Kit number	Descripción Description	Piezas Parts
1	Kit eje motriz Drive shaft kit	
2	Eje conducido Driven shaft	
3	Kit juntas Seals kit	
4	Kit tapa delantera Front flange kit	

Nº de kit Kit number	Descripción Description	Piezas Parts
5	Tapa posterior Back cover	
6	Kit tornillos fijación Fixing screws kit	
7	Kit cojinetes apoyo Bearing assemblies kit	

NOTA: Consultar las referencias disponibles con el departamento comercial.
NOTE: For available references contact the sales department.

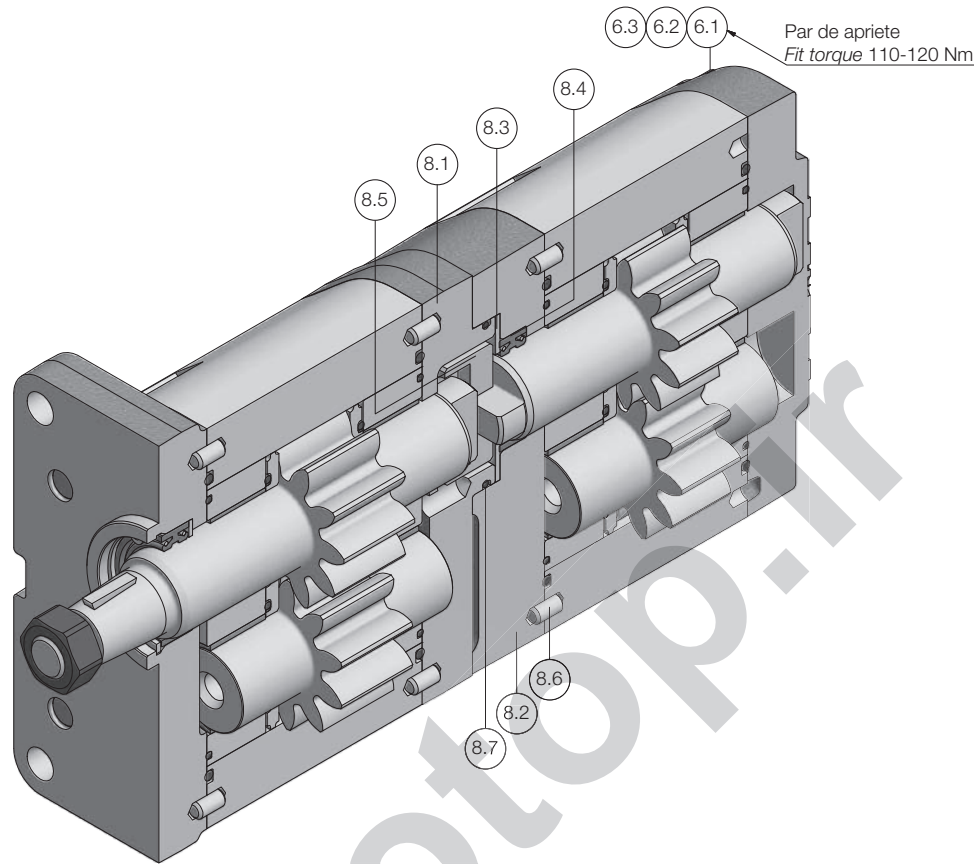

Nº de kit Kit number	Descripción Description	Piezas Parts
6	Kit tornillos fijación Fixing screws kit	

Nº de kit Kit number	Descripción Description	Piezas Parts
8	Kit tapas intermedias Intermediate flanges kit	

NOTA: Se puede crear una bomba doble PLL uniendo una bomba de referencia estándar y una bomba estándar con eje tipo L y tapa frontal tipo 26. Se ofrece el kit de tapas intermedias y el kit del eje tipo L para poder transformar la bomba.

NOTE: A PLL double pump can be assembled from a pump with standard reference and a pump with shaft form L and front flange type 26. The intermediate flanges kit and the L shaft kit are offered in order to transform the pump.

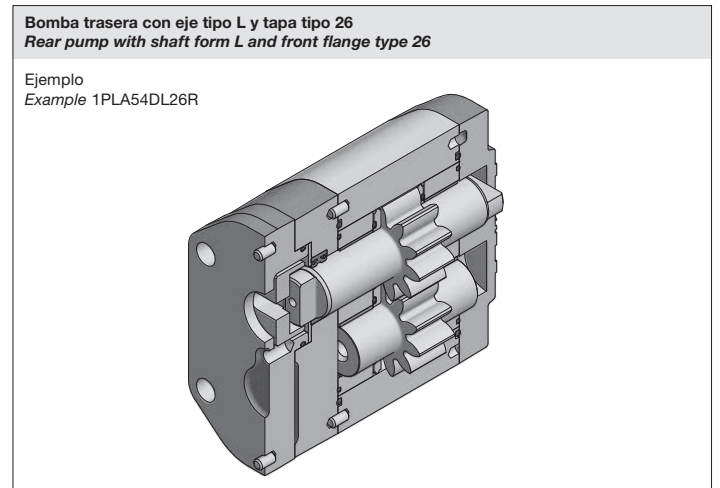
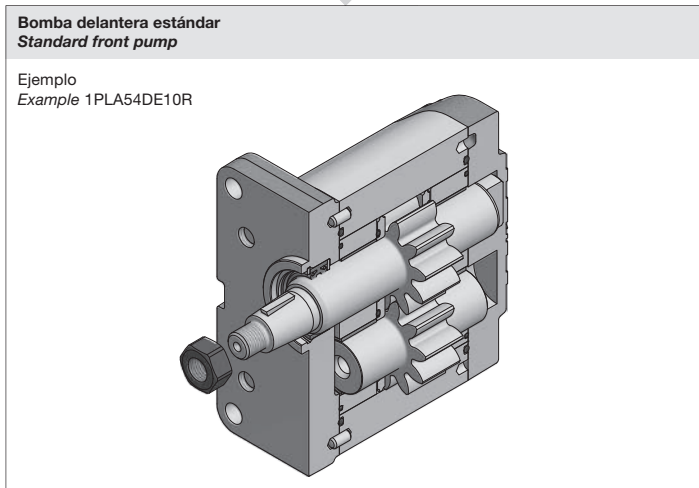

NOTA: Consultar las referencias disponibles con el departamento comercial. / **NOTE:** For available references contact the sales department.

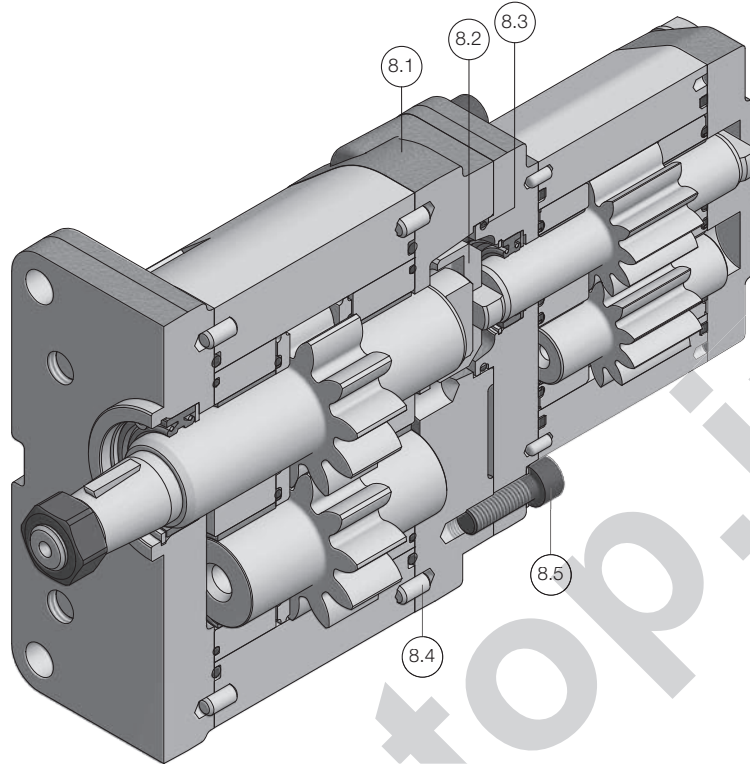

Nº de kit Kit number	Descripción Description	Piezas Parts
8	Kit tapa intermedia Intermediate flange kit	

NOTA: Se puede crear una bomba doble PLD uniendo una bomba PLA estándar, un kit de tapa intermedia y una bomba L estándar con eje tipo B y tapa frontal tipo 40.

NOTE: A PLD double pump can be assembled from a standard PLA pump, an intermediate flange kit and a standard L pump with shaft form B and front flange type 40.

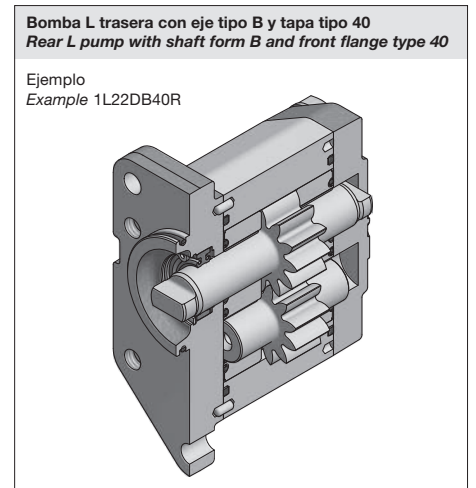
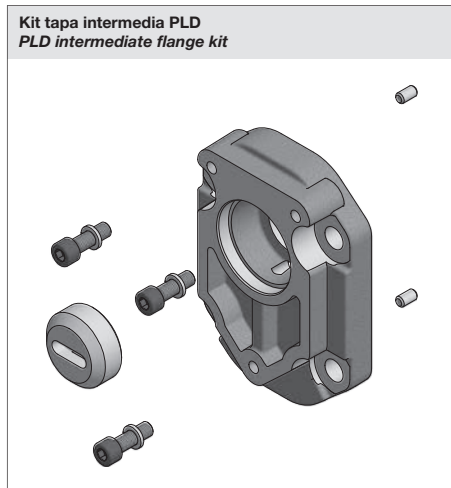
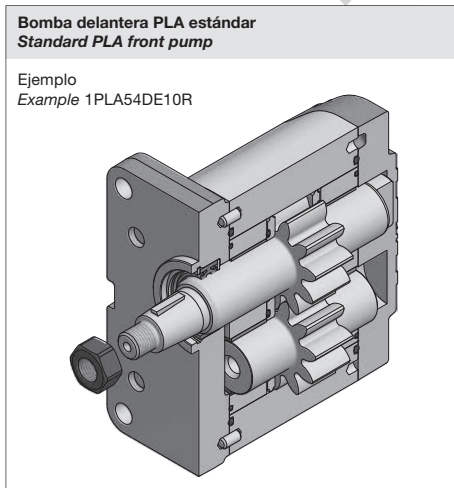

NOTA: Consultar las referencias disponibles con el departamento comercial. / **NOTE:** For available references contact the sales department.

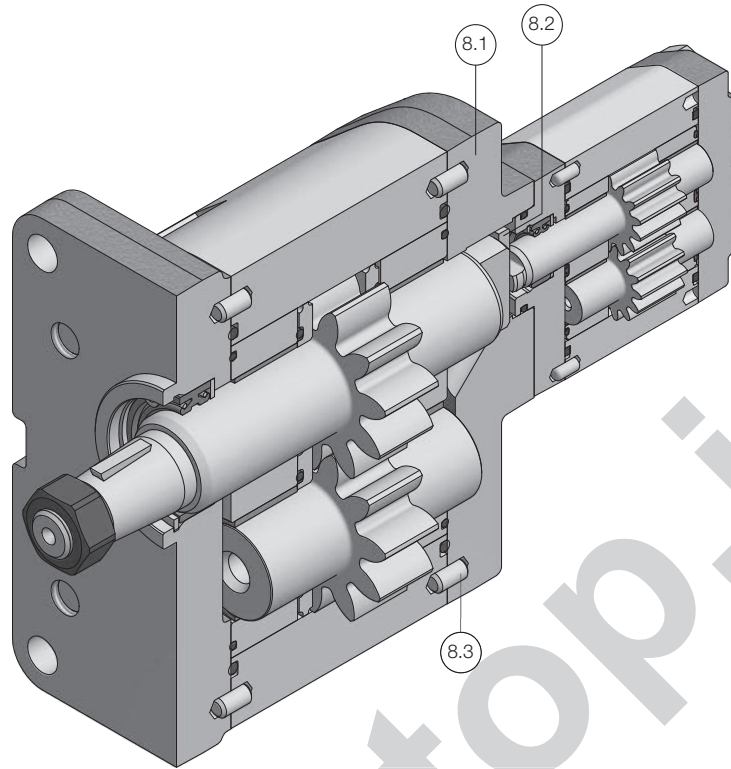

Nº de kit Kit number	Descripción Description	Piezas Parts
8	Kit tapa intermedia Intermediate flange kit	

NOTA: Se puede crear una bomba doble PLT uniendo una bomba PLA estándar, un kit de tapa intermedia y una bomba L0 estándar con eje tipo B y tapa frontal tipo 24 (tapa tipo 22 + tornillos de fijación bomba posterior).

NOTE: A PLT double pump can be assembled from a standard PLA pump, an intermediate flange kit and a standard L0 pump with shaft form B and front flange type 24 (front flange type 22 + rear pump fixing screws).

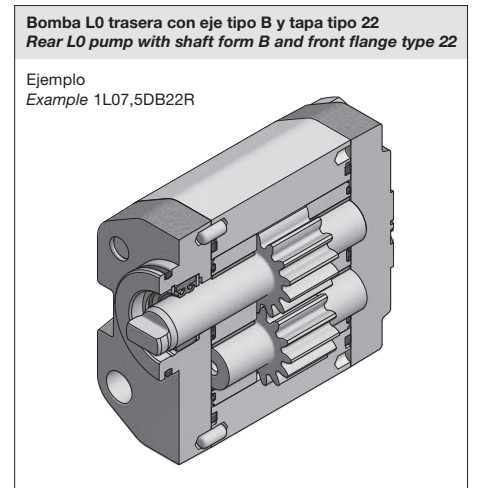
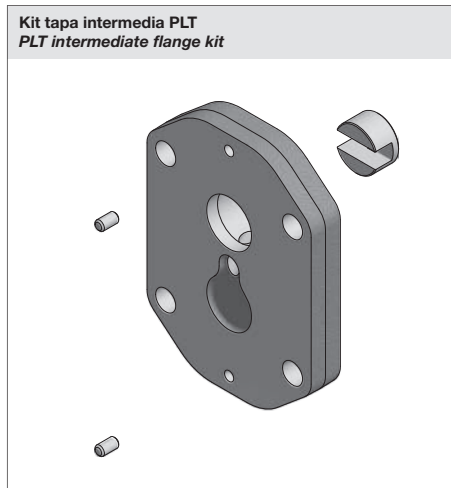
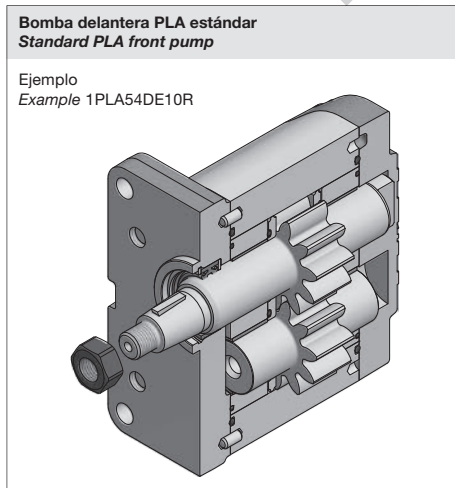

NOTA: Consultar las referencias disponibles con el departamento comercial. / **NOTE:** For available references contact the sales department.

hydrotop.ir

Roquet
making moves

Roquet
making moves
www.roquetgroup.com