

*PNC*  
*BOMBAS DE ENGRANAJES*  
*GEAR PUMPS*

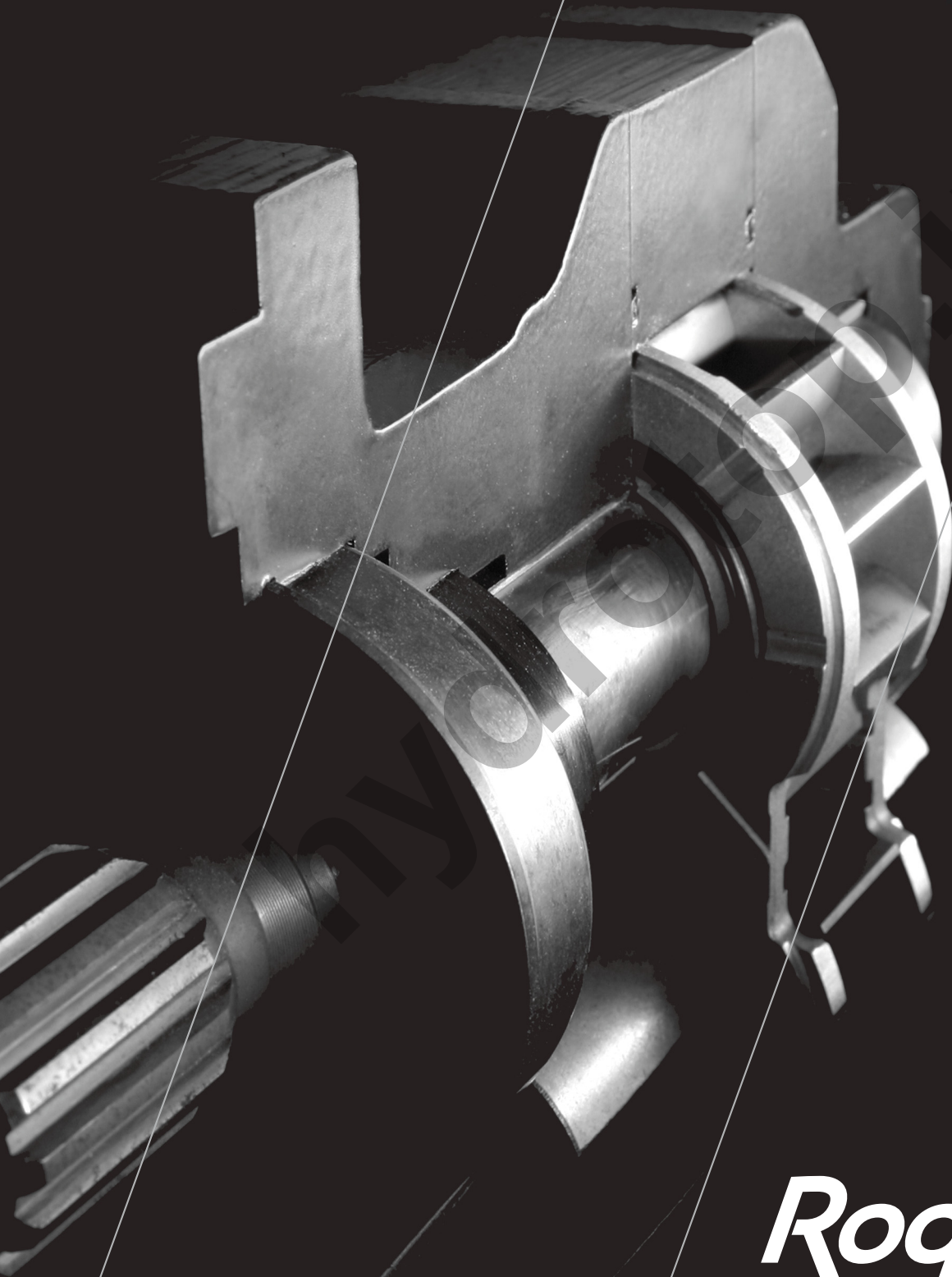

***Roquet***  
*making moves*

**HISTORIA** Más de medio siglo de trayectoria especializada en óleo-dinámica. Roquet es proveedor internacional en los sectores agrícola, naval, manutención, máquina-herramienta, automoción pesada, maquinaria de obras públicas, minería, eólica, alimentación, etc. Marca líder en España y una referencia importante en el ámbito internacional.

**TECNOLOGÍA** Roquet dispone de un importante departamento de diseño y desarrollo, con bancos de prueba de fatiga, nivel sonoro, resistencia a la corrosión, etc, apoyados por un avanzado laboratorio metalográfico. Se realizan grandes inversiones en centros de mecanizado de última generación para mantener una óptima calidad-productividad. La mayoría de piezas críticas (correderas, piezas de fundición, ejes de bomba, etc) se fabrican íntegramente en la propia empresa.

**FIABILIDAD** Una extensa gama de productos robustos y resistentes. Diseñados para rendir, contruidos para durar. Todas las gamas de productos se someten a pruebas de vida en condiciones de trabajo realistas durante el diseño y desarrollo del producto. De esta forma se asegura su perfecta adaptación a las diversas aplicaciones finales tales como tractores, carretillas elevadoras, palas cargadoras, excavadoras, grúas, volquetes, muelles de carga... Se prueba el 100% de las unidades producidas, según procedimientos internos de prueba, antes de la expedición.

**CAPACIDAD** 400 profesionales en plantilla. Cinco plantas de producción con una superficie cubierta de 40.000 m<sup>2</sup>. Producción actual: 180.000 bombas, 300.000 cuerpos de distribuidor y 500.000 cilindros. Una red comercial de distribución extendida por más de 35 países de los 5 continentes.

**HISTORY** Over fifty years experience in fluid power. Supplier to international manufactures of agricultural, construction, mining, mechanical handling, machine-tool and food machinery. Main supplier to the Spanish market with rapidly increasing presence in European and world markets.

**TECHNOLOGY** Roquet has a large design and development department with substantial fatigue, noise, corrosion-resistance, cleanliness and testing facilities, backed by a well-equipped metallurgical laboratory.

**RELIABILITY** A broad range of robust products: designed to perform, built to last. All products ranges life-tested under realistic conditions during development to ensure their suitability for use in applications such as tractors, fork-lift trucks, loaders, excavators, cranes, dumpers, dock-levellers... Each and every product tested to a stringent test specification prior to shipment.

**CAPABILITY** 400 well trained employees. Five factories with a total floor area of 40.000m<sup>2</sup> Current production 180.000 pumps, 300.000 control valve bodies and 500.000 cylinders. Distribution network in over 35 countries.

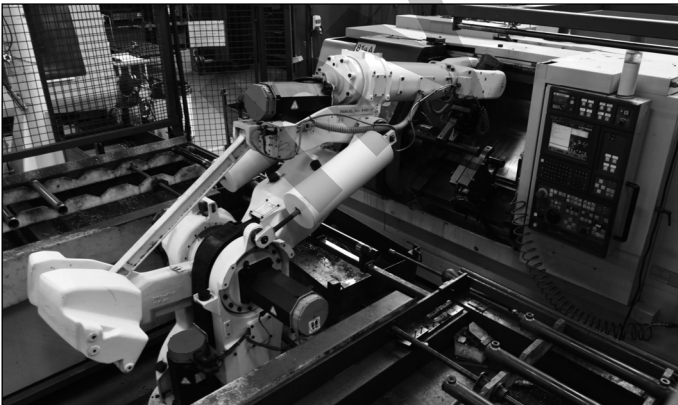
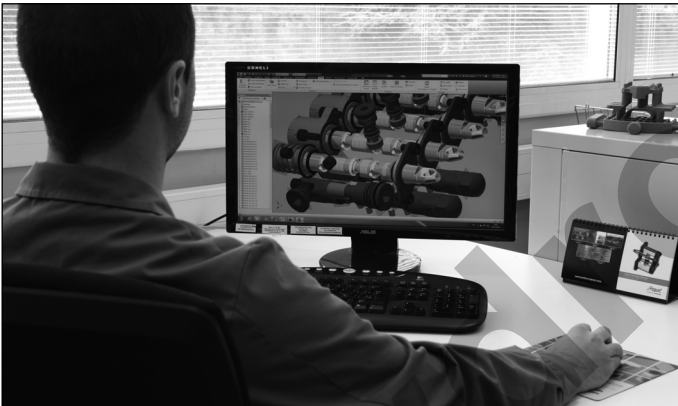

Este catálogo muestra los productos en su configuración más estándar. Para diseños personalizados o especiales, deberá ponerse en contacto con ROQUETHYDRAULICS, S.L. Las especificaciones y los datos de este catálogo no son susceptibles de interpretación. En caso de dudas, póngase en contacto con ROQUETHYDRAULICS, S.L.

ROQUETHYDRAULICS, S.L. se reserva el derecho de realizar modificaciones, actualizaciones o revisiones de este catálogo sin previo aviso. ROQUETHYDRAULICS, S.L. no es responsable de ningún daño provocado por un uso incorrecto del producto.

This Catalogue shows the product in the most standard configuration; customized or special designs are also available, please contact to ROQUETHYDRAULICS, S.L.

The specifications and data in this catalogue are not open to any interpretation, please contact with ROQUETHYDRAULICS, S.L. in case of doubt. ROQUETHYDRAULICS, S.L. reserves the right to modify, update or revise this catalogue without prior notice.

ROQUETHYDRAULICS, S.L. is not responsible for any damage caused by an incorrect use of the product.

Nuestras bombas están equilibradas hidrostáticamente y provistas de reajuste lateral automático.

Se recomienda el empleo de aceite para instalaciones oleodinámicas con aditivos antiespumantes y de extrema presión.

Para obtener una larga vida, tanto del aceite como de la bomba es preciso trabajar entre una viscosidad de 20 - 80 cSt, según presiones de trabajo a una temperatura de 50° C.

Gama de temperaturas del fluido hidráulico +5° C +80° C.

El apartado de filtraje es muy importante, ya que la mayoría de averías son debidas a la suciedad del aceite. Ver datos técnicos.

La mejor forma de accionamiento es de conexión directa por medio de un acoplamiento elástico, que permite un movimiento mínimo radial y axial de 0,3 a 0,4 mm, por lo que de esta forma quedarán absorbidas todas las vibraciones del motor que tanto perjudican la buena marcha de la bomba.

Los conductos de aspiración serán lo suficientemente dimensionados para que la depresión no exceda de 0,3 bars.

Conexión por bridas S.A.E. o rosca G.

Sentido de giro derecha o izquierda, mirando la bomba por el lado del eje.

Antes de poner por primera vez la bomba en marcha, asegurarse que el sentido de giro es el correcto.

Presentamos en el apartado de bombas dobles, varios tipos de fijación con sus ejes más normales. No obstante se podrán construir bombas dobles con las mismas fijaciones que las simples y sus ejes correspondientes.

Estas consideraciones también son validas para bombas triples y cuadruples, que podemos fabricar.

**NOTA IMPORTANTE: En versión estándar la conexión es de rosca G.**

Our pumps are hydrostatically balanced and have automatic lateral adjustment.

We recommend the use of the oil for oil-dynamic installations with antifoaming additives and for extreme pressure.

To obtain extended pump life it is necessary to work with oil viscosities between 20 - 80 cSt, relating to working pressure and at a temperature of 50°C.

Oil temperature range +5°C - +80°C.

Filtration is extremely important since most problems are due to oil contamination.

The most efficient drive method is by means of axial flexible coupling, with minimum 0,3 - 0,4 mm. radial and axial movement, thus reducing the effects of vibration and maintaining maximum efficiency of the pump.

The suction pipes should be large enough to ensure that cavitation does not exceed 0,3 Bar.

Connection by SAE flange or threaded G.

Rotation direction: Clockwise or anti-clockwise when facing the shaft end.

Before starting the pump, make sure the direction of rotation is correct.

Double and multiple pumps are available with all shafts and flanges shown for single pumps.

**IMPORTANT NOTE: Side ports threaded G are available as standard version.**

**Índice / Index**

**Bomba de engranajes / Gear pump PNC**

Datos técnicos / Technical data .....	<b>4-5</b>
Sistema de codificación / Coding system .....	<b>6</b>
Tapa tipo 01 / Front flange type 01 .....	<b>7</b>
Tapa tipo 10 / Front flange type 10 .....	<b>8</b>
Tapa tipo 09 / Front flange type 09 .....	<b>9</b>
Tapa tipo 50 / Front flange type 50 .....	<b>10</b>

**Bomba de engranajes / Gear pump PNJ**

Tapa tipo 09 / Front flange type 09 .....	<b>11</b>
---	-----------

**Bomba de engranajes / Gear pump PNK**

Tapa tipo 09 / Front flange type 09 .....	<b>12</b>
---	-----------

**Bomba de engranajes / Gear pump PNH**

Tapa tipo 09 / Front flange type 09 .....	<b>13</b>
---	-----------

**Sección / Section**

PNK .....	<b>14</b>
PNH .....	<b>14</b>



<b>Caudal bomba</b> <i>Pump flow rate</i>	L/min. 1500 R.P.M. (US. GPM 1500 RPM)	80 (21)	100 (26)	125 (33)	150 (39)	175 (46)	200 (53)	225 (59)
<b>Cilindrada</b> <i>Displacement</i>	cm <sup>3</sup> /v - cc/rev (in <sup>3</sup> /rev)	53,3 (3,27)	66,6 (4,06)	83,3 (5,08)	100 (6,10)	116,6 (7,11)	133,3 (8,13)	150 (9,15)
<b>Presión máx. continua en</b> <i>Cont. max. pressure</i>	bar (PSI)	260 (3700)		250 (3550)		225 (3200)	200 (2850)	175 (2500)
<b>Presión máx. inter 5 seg. max.</b> <i>Intermittent max. pressure</i>	bar (PSI)	290 (4100)		275 (3900)		250 (3550)	225 (3200)	200 (2850)
<b>R.P.M. máximas</b> <i>Max. R.P.M.</i>		3000				2500	2000	1750
<b>Mínimas R.P.M. según presión</b> <i>Min. R.P.M. at given pressures</i>	100 bar (1425 PSI)	400				350		
	175 bar (2500 PSI)	450				400		
	250 bar (3550 PSI)	550				-	-	-
<b>Aceite recomendado</b> <i>Fluid to be used</i>	ISO 6743 tipo HM, HV ó HG							
<b>Viscosidad</b> <i>Viscosity range</i>	ISO 3448 cat. VG32-VG46							
<b>Grado de limpieza del aceite</b> <i>Recommended fluid cleanliness</i>	19/16 s/. ISO 4406 ó RP70H							
<b>Temperatura de trabajo del aceite</b> <i>Oil temperature</i>	-20°C... +80°C -4°F... +176°F							
<b>Temperatura ambiente</b> <i>Ambient temperature</i>	-20°C... +80°C -4°F... +176°F							

Diagramas / Diagrams

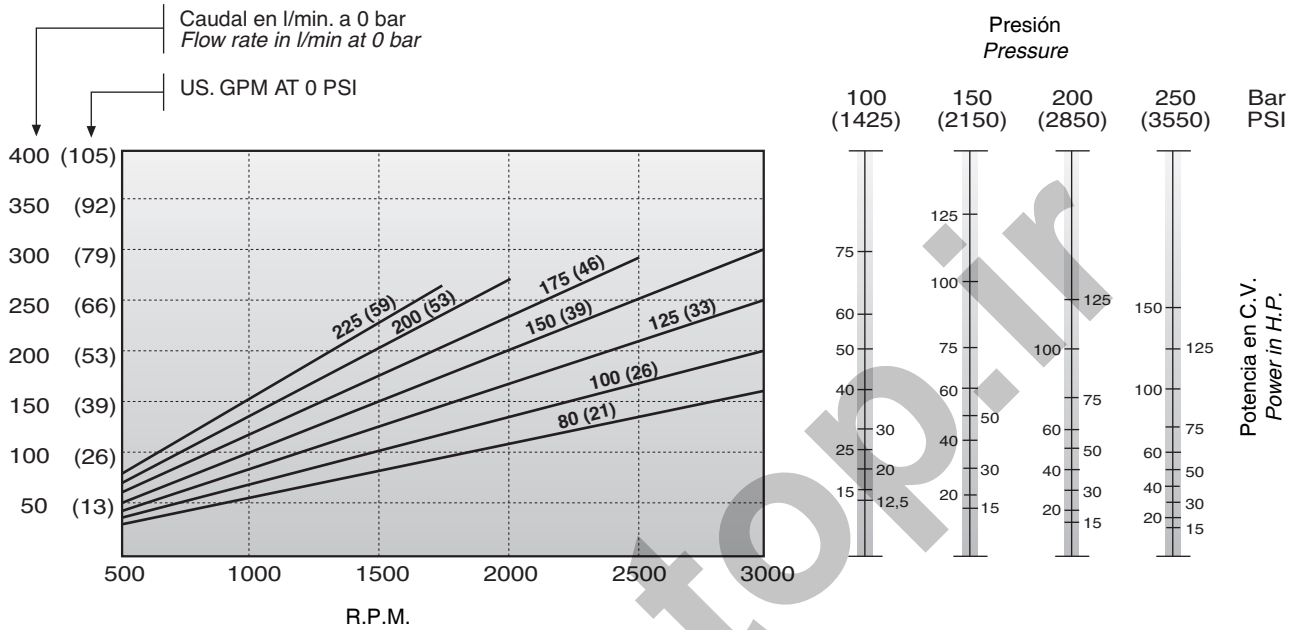

NOTA: Estos diagramas han sido obtenidos con un aceite de viscosidad VG 46 y una temperatura de 50°C.  
NOTE: These results have been obtained with VG 46 viscosity oil and at 50 deg. C (122°F).

**SISTEMA DE CODIFICACIÓN**

1 PNC 80 D A 01 M \*

**CODING SYSTEM**

Tipo / Type	
1	Sin polea / Without pulley
13	Con cojinete de apoyo y retén. <i>With ball bearing and shaft SEAL</i>
14	Con dos retenes y fuga exterior. <i>With two shafts seals and external drain.</i>

Modelo / Model	
PNC	Bomba de engranajes <i>Gear pump</i>
PNJ	Bomba múltiple <i>Multiple-banked</i> PNC + PNC
PNK	Bomba múltiple <i>Multiple-banked</i> PNC + PNA
PNH	Bomba múltiple <i>Multiple-banked</i> PNC + L
PNZ	Bomba múltiple <i>Multiple-banked</i> PNC + LO

Caudal bomba a 1500 RPM a 0 bar <i>Pump flow rate at 1500 RPM and 0 bar</i>	
Ver hoja técnica <i>See technical data</i>	

Datos adicionales <i>Additional data</i>

Formas conexión tomas <i>Port connection form</i>
R M (S.A.E.) R F B

Tipo tapas / Fixing flange
01 - 09 - 10 - 11 - 50

Forma eje motriz / Driving shaft form
A - E - F - G - H - J - S - X

Sentido de giro / Rotation direction	
D	Derecha <i>Clockwise</i>
I	Izquierda <i>Counterclockwise</i>

### Tapa tipo / Front flange type 01

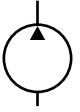

#### Eje forma A / Shaft form A

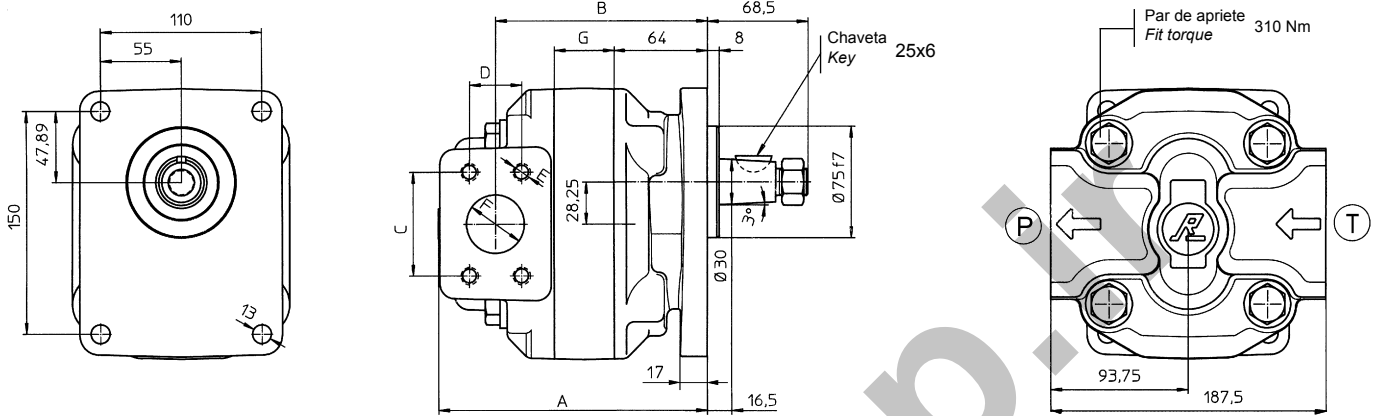

Sentido de giro Rotation sense	Aspiración Suction	Presión Pressure
*D Derecha Clockwise	T	P
*I Izquierda Counter Clockwise	P	T

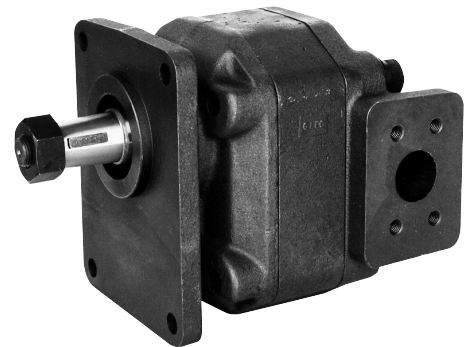
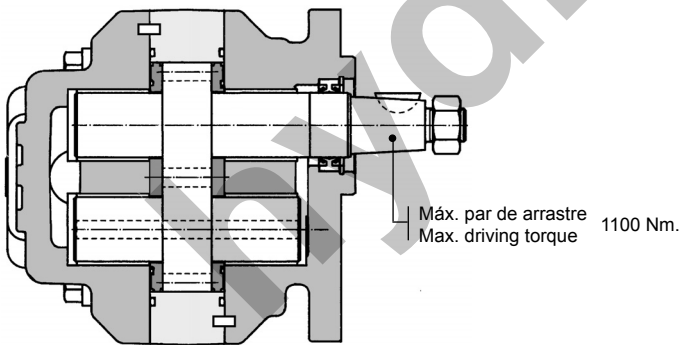

Referencia Reference	Cilindrada cm <sup>3</sup> /v Displacement cc/r.	G	A	B	Presión Pressure				Aspiración Suction				Peso Weight Kg.
					C	D	E	F	C	D	E	F	
1 PNC80* A01M	53,3	41	184	145	58,7	30,2	M.10	32	69,8	35,7	M.12	38	23
1 PNC100* A01M	66,6	47,5	190,5	151,5									24
1 PNC125* A01M	83,3	55,5	198,5	159,5									25
1 PNC150* A01M	100	64	207	168	69,8	35,7	M.12	38	77,8	42,9	M.12	50	26
1 PNC175* A01M	116,6	72	215	176									27
1 PNC200* A01M	133,3	80,5	223,5	184,5									28
1 PNC225* A01M	150	88,5	231,5	192,5									29

### Tapa tipo / Front flange type 10

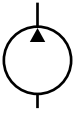

#### Eje forma E / Shaft form E

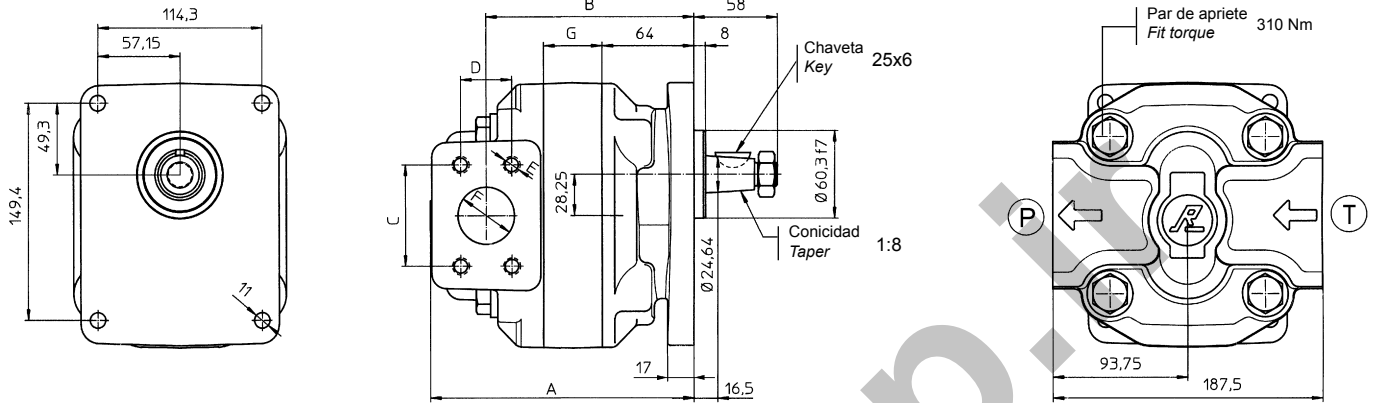

Sentido de giro Rotation sense	Aspiración Suction	Presión Pressure
*D Derecha Clockwise	T	P
*I Izquierda Counter Clockwise	P	T

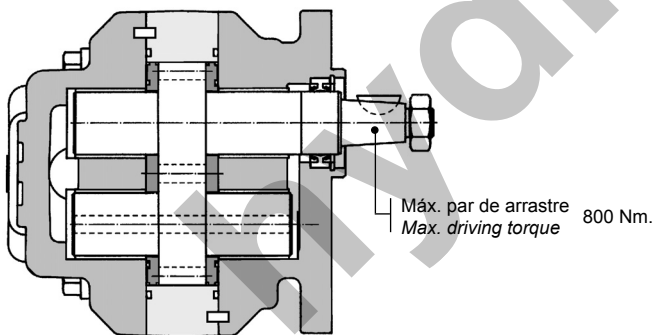

Referencia Reference	Cilindrada cm <sup>3</sup> /v Displacement cc/r.	G	A	B	Presión Pressure				Aspiración Suction				Peso Weight Kg.	
					C	D	E	F	C	D	E	F		
1 PNC80*E10M	53,3	41	184	145										23
1 PNC100*E10M	66,6	47,5	190,5	151,5	58,7	30,2	M.10	32	69,8	35,7	M.12	38		24
1 PNC125*E10M	83,3	55,5	198,5	159,5										25
1 PNC150*E10M	100	64	207	168										26
1 PNC175*E10M	116,6	72	215	176										27
1 PNC200*E10M	133,3	80,5	223,5	184,5	69,8	35,7	M.12	38	77,8	42,9	M.12	50		28
1 PNC225*E10M	150	88,5	231,5	192,5										29



### Tapa tipo / Front flange type 09

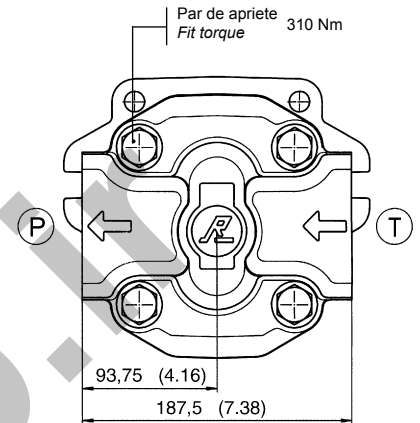
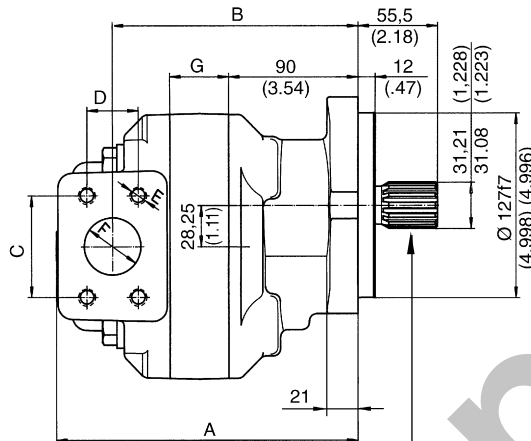
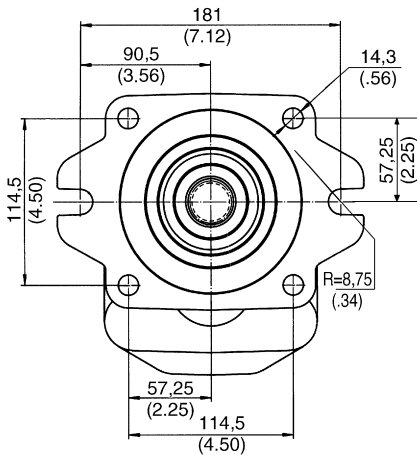
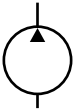

#### Eje forma / Shaft form G

Características / Spline data  
ANSI B92.1  
Diametral pitch 12/24  
Ángulo de presión 30° / Pressure angle 30°  
Nº de dientes 14 / Teeth number 14

Sentido de giro Rotation sense	Aspiración Suction	Presión Pressure
*D Derecha Clockwise	T	P
*I Izquierda Counter Clockwise	P	T

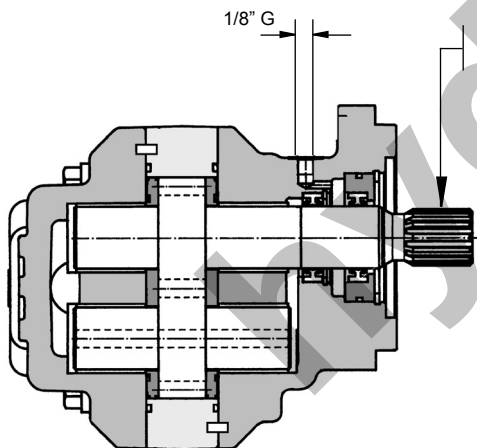

▲ 14 PNC... Con dos retenes y fuga exterior.  
With two shafts seals and external drain.

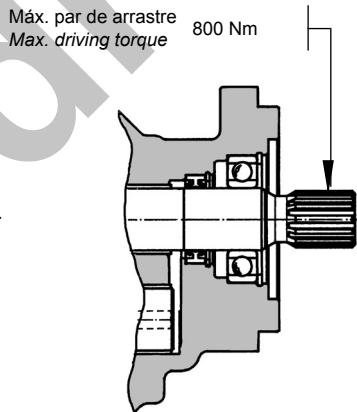

▲ 13 PNC... Con cojinete de apoyo y retén.  
With ball bearing and shaft seal.



Referencia Reference	Cilindrada cm <sup>3</sup> /v Displacement cc/r.		G		A		B		Presión Pressure				Aspiración Suction				Peso Weight	
	cm <sup>3</sup> /v cc/r.	in <sup>3</sup> /rev.	mm	in.	mm	in.	mm	in.	C	D	E	F	C	D	E	F	Kg.	Lb.
▲ PNC80*G09M	53,3	3,27	41	(1,61)	210	(8,26)	171	(6,73)									25,5	56,1
▲ PNC100*G09M	66,6	4,06	47,5	(1,87)	216,5	(8,52)	177,5	(6,98)	58,7 (2,31)	30,2 (1,18)	M.10	32 (1,25)	69,8 (2,75)	35,7 (1,40)	M.12	38 (1,49)	26,5	58,3
▲ PNC125*G09M	83,3	5,08	55,5	(2,18)	224,5	(8,83)	185,5	(7,30)									27,5	60,5
▲ PNC150*G09M	100	6,10	64	(2,51)	233	(9,17)	194	(7,63)									28,5	62,7
▲ PNC175*G09M	116,6	7,11	72	(2,83)	241	(9,48)	202	(7,95)	69,8 (2,75)	35,7 (1,40)	M.12	38 (1,49)	77,8 (3,06)	42,9 (1,68)	M.12	50 (1,96)	29,5	64,9
▲ PNC200*G09M	133,3	8,13	80,5	(3,16)	249,5	(9,82)	210,5	(8,28)									30,5	67,1
▲ PNC225*G09M	150	9,15	88,5	(3,48)	257,5	(10,13)	218,5	(8,60)									31,5	69,3

### Tapa tipo / Front flange type 50

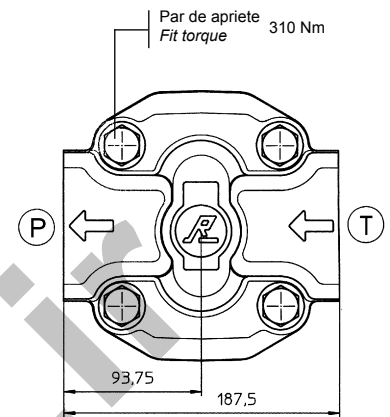
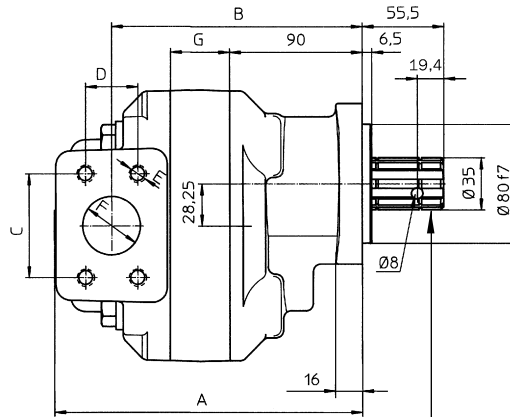
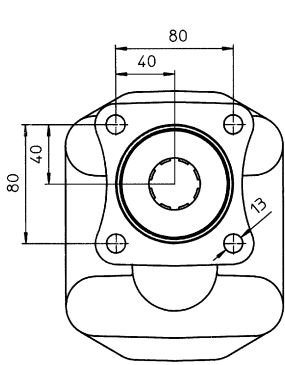
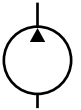

**Eje forma / Shaft form X**  
 Características / Spline data  
 DIN-5462  
 B - 8 x 32 x 36  
 Ancho del diente 6 H8 / Tooth width 6 H8  
 N° de dientes 8 / Teeth number 8

Sentido de giro Rotation sense	Aspiración Suction	Presión Pressure
*D Derecha Clockwise	T	P
*I Izquierda Counter Clockwise	P	T

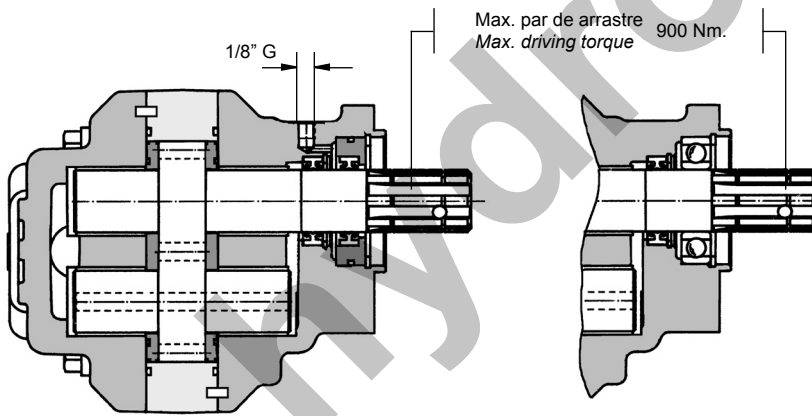

▲ 14 PNC... Con dos retenes y fuga exterior.  
 With two shafts seals and external drain.

▲ 13 PNC... Con cojinete de apoyo y retén.  
 With ball bearing and shaft seal.

Referencia Reference	Cilindrada cm <sup>3</sup> /v Displacement cc/r.	G	A	B	Presión Pressure				Aspiración Suction				Peso Weight Kg.
					C	D	E	F	C	D	E	F	
▲ PNC80* X50M	53,3	41	210	171	58,7	30,2	M.10	32	69,8	35,7	M.12	38	24,5
▲ PNC100* X50M	66,6	47,5	216,5	177,5									25,5
▲ PNC125* X50M	83,3	55,5	224,5	185,5									26,5
▲ PNC150* X50M	100	64	233	194	69,8	35,7	M.12	38	77,8	42,9	M.12	50	27,5
▲ PNC175* X50M	116,6	72	241	202									28,5
▲ PNC200* X50M	133,3	80,5	249,5	210,5									29,5
▲ PNC225* X50M	150	88,5	257,5	218,5									30,5

Tapa tipo / Front flange type 09

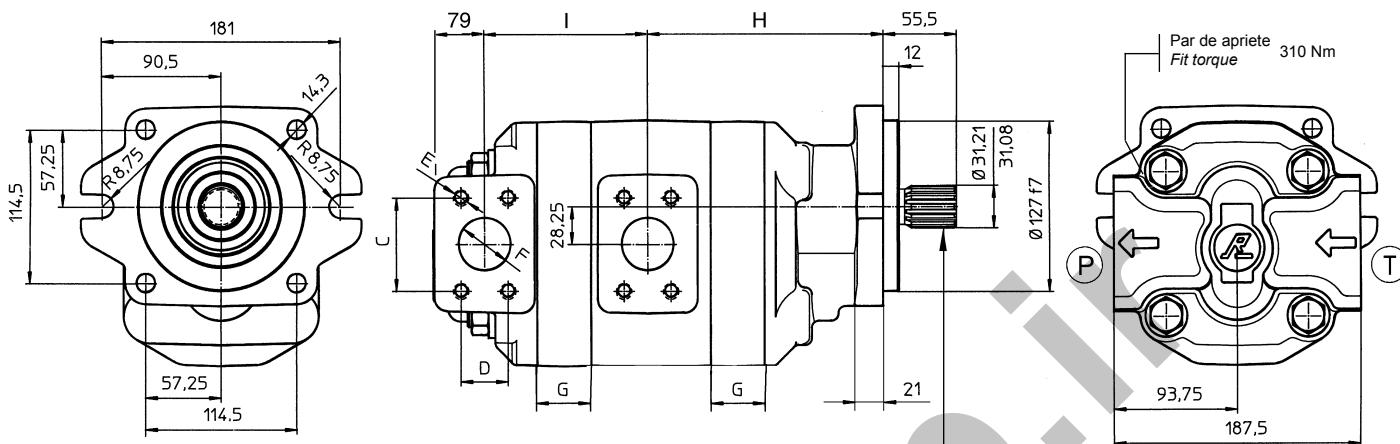
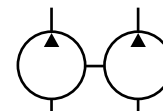

Sentido de giro Rotation sense	Aspiración Suction	Presión Pressure
*D Derecha Clockwise	T	P
*I Izquierda Counter Clockwise	P	T

Eje forma / Shaft form G
Características / Spline data
ANSI B92.1
Diametral pitch 12/24
Ángulo de presión 30° / Pressure angle 30°
Nº de dientes 4 / Teeth number 14

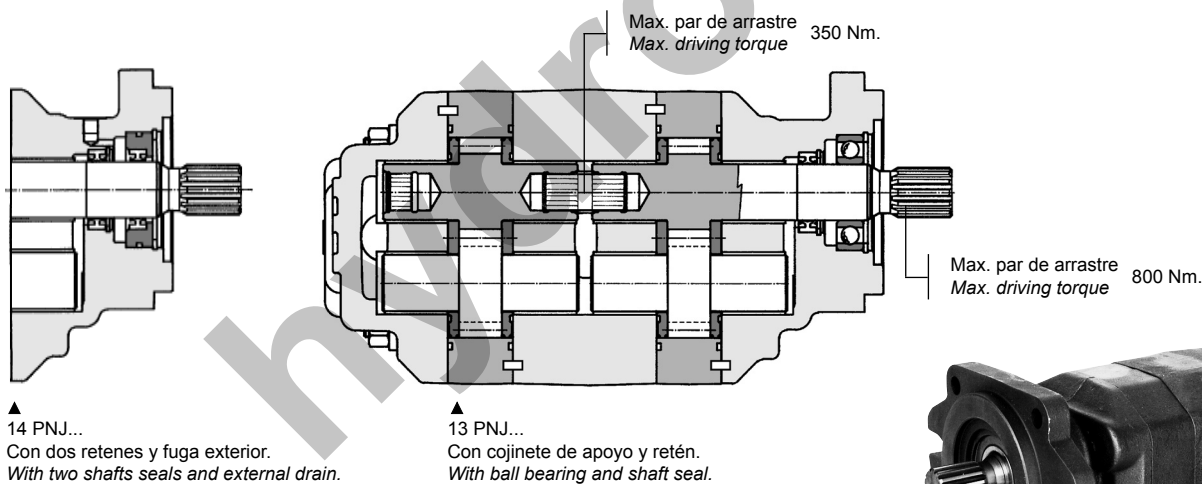

▲ 14 PNJ...  
Con dos retenes y fuga exterior.  
With two shaft seals and external drain.

▲ 13 PNJ...  
Con cojinete de apoyo y retén.  
With ball bearing and shaft seal.

- Sustituir por el caudal deseado a 1500 rpm  
Replace with flow at 1500 rpm



Referencia Reference	G	H	I	Presión Pressure				Aspiración Suction			
				C	D	E	F	C	D	E	F
▲ PNJ80-●*G09M	41	179	124	58,7	30,2	M.10	32	69,8	35,7	M.12	38
▲ PNJ100-●*G09M	47,5	185,5	130,5								
▲ PNJ125-●*G09M	55,5	193,5	138,5								
▲ PNJ150-●*G09M	64	202	147								
▲ PNJ175-●*G09M	72	290	155	69,8	35,7	M.12	38	77,8	42,9	M.12	50
▲ PNJ200-●*G09M	80,5	218,5	163,5								
▲ PNJ225-●*G09M	88,5	226,5	171,5								

### Tapa tipo / Front flange type 09

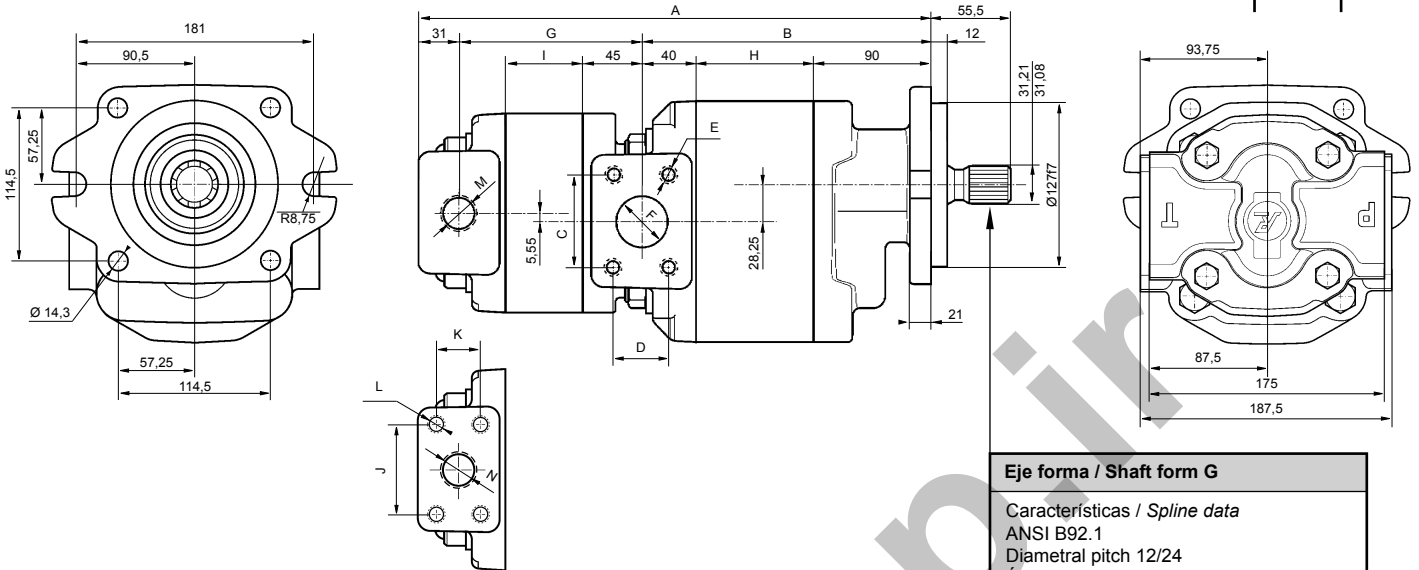

**Eje forma / Shaft form G**  
 Características / Spline data  
 ANSI B92.1  
 Diametral pitch 12/24  
 Ángulo de presión 30° / Pressure angle 30°  
 N° de dientes 14 / Teeth number 14

Sentido de giro Rotation sense	Aspiración Suction	Presión Pressure
*D Derecha Clockwise	T	P
*I Izquierda Counter Clockwise	P	T

Referencia Reference	Cilindrada Displacement cm <sup>3</sup> /v		A	B	G	H	I	Presión / Pressure Conexión / Connection M (S.A.E.)							Aspiración / Suction Conexión / Connection M (S.A.E.)												
	PNC	PNA						C	D	E	F	J	K	L	N	M	R	C	D	E	F	J	K	L	N	M	R
	▲ PNK 80 - 36 *G09MR	24						314	53.3	171	111.5	41	31.5	58.7	30.2	M.10	Ø32	52.4	26.2	M.10	26	3/4" G	69.8	35.7	M.12	Ø38	58.7
45 *G09MR	30	319	116.5	36.5																							
54 *G09MR	36	324	121.5	41.5																							
66 *G09MR	44	330	128	48																							
▲ PNK 100 - 36 *G09MR	24	320	66.6	177.5	111.5	47.5	31.5	58.7																			
45 *G09MR	30	325							116.5	36.5																	
54 *G09MR	36	330							121.5	41.5																	
66 *G09MR	44	337							128	48																	
84 *G09MR	56	346							137.5	57.5																	
96 *G09MR	64	353	144.5	64.5																							
▲ PNK 125 - 36 *G09MR	24	328	83.3	185.5	111.5	55.5	31.5	58.7	30.2	M.10	Ø32	52.4	26.2	M.10	26	3/4" G	69.8	35.7	M.12	Ø38	58.7	30.2	M.10	32	1" G		
45 *G09MR	30	333																								116.5	36.5
54 *G09MR	36	338																								121.5	41.5
66 *G09MR	44	345																								128	48
84 *G09MR	56	354																								137.5	57.5
96 *G09MR	64	361	144.5	64.5																							
110 *G09MR	73.3	369	152	72																							
▲ PNK 150 - 36 *G09MR	24	337	100	194	111.5	64	31.5	58.7	35.7	M.12	Ø38	52.4	26.2	M.10	26	3/4" G	77.8	42.9	M.12	Ø50	58.7	30.2	M.10	32	1" G		
45 *G09MR	30	342																								116.5	36.5
54 *G09MR	36	347																								121.5	41.5
66 *G09MR	44	353																								128	48
84 *G09MR	56	363																								137.5	57.5
96 *G09MR	64	370	144.5	64.5																							
110 *G09MR	73.3	377	152	72																							
▲ PNK 175 - 36 *G09MR	24	345	116.6	202	111.5	72	31.5	58.7	35.7	M.12	Ø38	52.4	26.2	M.10	26	3/4" G	77.8	42.9	M.12	Ø50	58.7	30.2	M.10	32	1" G		
45 *G09MR	30	350																								116.5	36.5
54 *G09MR	36	355																								121.5	41.5
66 *G09MR	44	361																								128	48
84 *G09MR	56	371																								137.5	57.5
96 *G09MR	64	378	144.5	64.5																							
110 *G09MR	73.3	385	152	72																							
▲ PNK 200 - 36 *G09MR	24	353	133.3	210.5	111.5	80.5	31.5	58.7	35.7	M.12	Ø38	52.4	26.2	M.10	26	3/4" G	77.8	42.9	M.12	Ø50	58.7	30.2	M.10	32	1" G		
45 *G09MR	30	358																								116.5	36.5
54 *G09MR	36	363																								121.5	41.5
66 *G09MR	44	370																								128	48
84 *G09MR	56	379																								137.5	57.5
96 *G09MR	64	386	144.5	64.5																							
110 *G09MR	73.3	394	152	72																							
▲ PNK 225 - 36 *G09MR	24	361	150	218.5	111.5	88.5	31.5	58.7	35.7	M.12	Ø38	52.4	26.2	M.10	26	3/4" G	77.8	42.9	M.12	Ø50	58.7	30.2	M.10	32	1" G		
45 *G09MR	30	366																								116.5	36.5
54 *G09MR	36	371																								121.5	41.5
66 *G09MR	44	378																								128	48
84 *G09MR	56	387																								137.5	57.5
96 *G09MR	64	394	144.5	64.5																							
110 *G09MR	73.3	402	152	72																							

### Tapa tipo / Front flange type 09

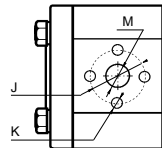
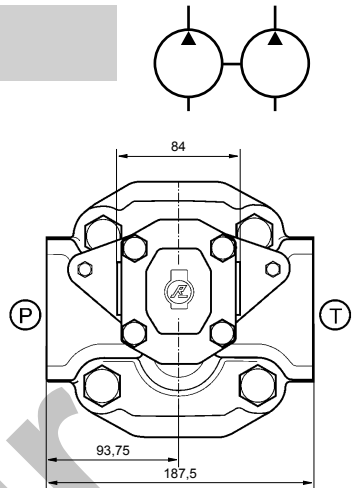
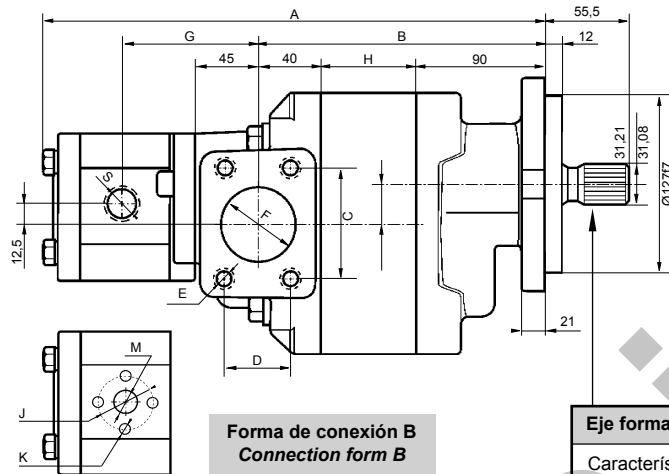
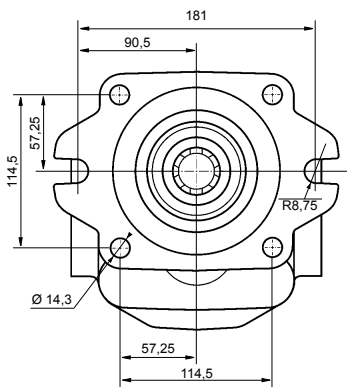

**Forma de conexión B**  
Connection form B

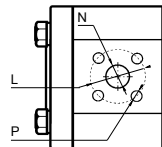

**Forma de conexión F**  
Connection form F

**Eje forma / Shaft form G**

Características / Spline data  
ANSI B92.1  
Diametral pitch 12/24  
Angulo de presión 30° / Pressure angle 30°  
Nº de dientes 14 / Teeth number 14

Sentido de giro Rotation sense	Aspiración Suction	Presión Pressure
*D Derecha Clockwise	T	P
*I Izquierda Counter Clockwise	P	T

Referencia Reference	Cilindrada Displacement cm <sup>3</sup> /v		A	B	G	H	Presión / Pressure Conexión / Connection												Aspiración / Suction Conexión / Connection																	
	PNC	L					M(S.A.E.)						R			B			F			M(S.A.E.)						R			B			F		
							C	D	E	F	S	J	K	M	L	P	N	C	D	E	F	S	J	K	M	L	P	N								
▲ PNH 80 - 9 *G09MR	6	304	53.3	171	82.5	41	58.7	30.2	M.10	Ø32	3/8" G	30	M.6	15	35	M.6	15	69.8	35.7	M.12	Ø38	1/2" G	30	M6	13.5	40	M.8	20	40	M.6	20					
12 *G09MR	8	308																														88				
16 *G09MR	10.6	312																														88				
22 *G09MR	14.6	319																														88				
27 *G09MR	18	325																														88				
35 *G09MR	23.3	334	95.5																																	
▲ PNH 100 - 9 *G09MR	6	311	66.6	177.5	82.5	47.5	58.7	30.2	M.10	Ø32	3/8" G	30	M.6	15	35	M.6	15	69.8	35.7	M.12	Ø38	1/2" G	30	M6	13.5	40	M.8	20	40	M.6	20					
12 *G09MR	8	314																														88				
16 *G09MR	10.6	319																														88				
22 *G09MR	14.6	325																														88				
27 *G09MR	18	331																														88				
35 *G09MR	23.3	340	96.5																																	
▲ PNH 125 - 9 *G09MR	6	319	83.3	185.5	82.5	55.5	58.7	30.2	M.10	Ø32	3/8" G	30	M.6	15	35	M.6	15	69.8	35.7	M.12	Ø38	1/2" G	30	M6	13.5	40	M.8	20	40	M.6	20					
12 *G09MR	8	322																														88				
16 *G09MR	10.6	327																														88				
22 *G09MR	14.6	333																														88				
27 *G09MR	18	339																														88				
35 *G09MR	23.3	348	96.5																																	
▲ PNH 150 - 9 *G09MR	6	327	100	194	82.5	64	69.8	35.7	M.12	Ø38	3/8" G	30	M.6	15	35	M.6	15	77.8	42.9	M.12	Ø50	1/2" G	30	M6	13.5	40	M.8	20	40	M.6	20					
12 *G09MR	8	331																														88				
16 *G09MR	10.6	335																														88				
22 *G09MR	14.6	342																														88				
27 *G09MR	18	348																														88				
35 *G09MR	23.3	357	96.5																																	
▲ PNH 175 - 9 *G09MR	6	335	116.6	202	82.5	72	69.8	35.7	M.12	Ø38	3/8" G	30	M.6	15	35	M.6	15	77.8	42.9	M.12	Ø50	1/2" G	30	M6	13.5	40	M.8	20	40	M.6	20					
12 *G09MR	8	339																														88				
16 *G09MR	10.6	343																														88				
22 *G09MR	14.6	350																														88				
27 *G09MR	18	356																														88				
35 *G09MR	23.3	365	96.5																																	
▲ PNH 200 - 9 *G09MR	6	344	133.3	210.5	82.5	80.5	69.8	35.7	M.12	Ø38	3/8" G	30	M.6	15	35	M.6	15	77.8	42.9	M.12	Ø50	1/2" G	30	M6	13.5	40	M.8	20	40	M.6	20					
12 *G09MR	8	347																														88				
16 *G09MR	10.6	351																														88				
22 *G09MR	14.6	358																														88				
27 *G09MR	18	364																														88				
35 *G09MR	23.3	373	96.5																																	
▲ PNH 225 - 9 *G09MR	6	352	150	21.5	82.5	88.5	69.8	35.7	M.12	Ø38	3/8" G	30	M.6	15	35	M.6	15	77.8	42.9	M.12	Ø50	1/2" G	30	M6	13.5	40	M.8	20	40	M.6	20					
12 *G09MR	8	355																														88				
16 *G09MR	10.6	360																														88				
22 *G09MR	14.6	366																														88				
27 *G09MR	18	372																														88				
35 *G09MR	23.3	381	96.5																																	

**PNK**

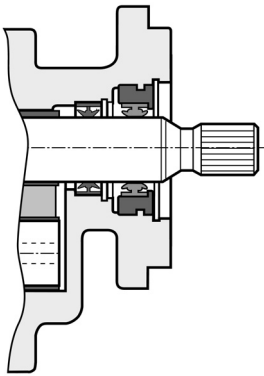

▲ 14 PNK... Con dos retenes y fuga exterior.  
*With two shaft seals and external drain.*

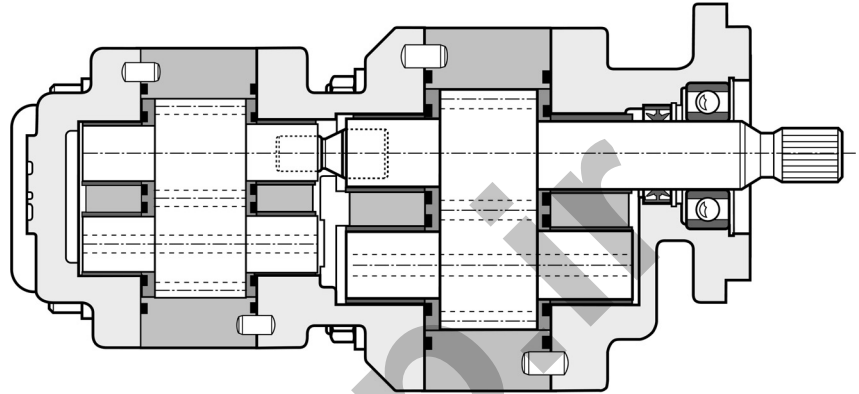

▲ 13 PNK... Con cojinete de apoyo y retén.  
*With ball bearing and shaft seal.*

**PNH**

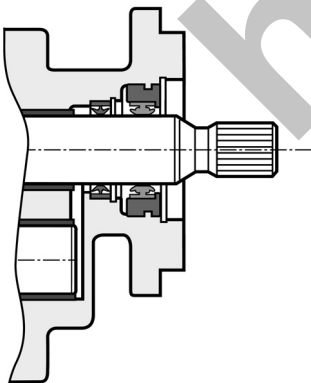

▲ 14 PNH... Con dos retenes y fuga exterior.  
*With two shaft seals and external drain.*

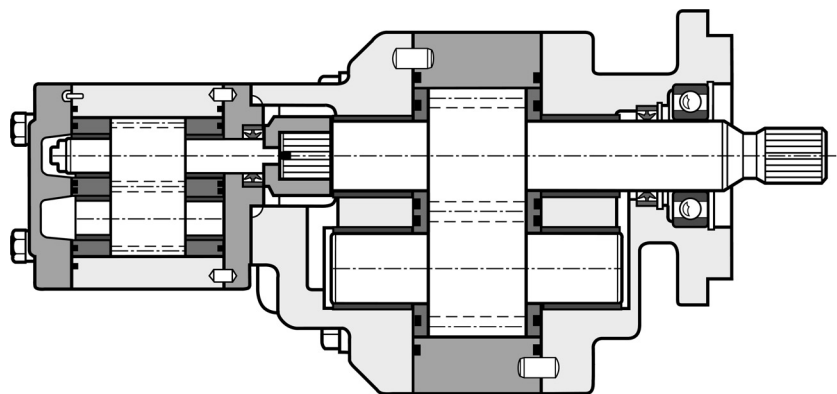

▲ 13 PNH... Con cojinete de apoyo y retén.  
*With ball bearing and shaft seal.*

Hydrotopir

**Roquet**  
*making moves*

[www.roquetgroup.com](http://www.roquetgroup.com)

hydrotop.ir