

---

# 1.5PE

---

## Aluminium gear pumps

---

### Technical Catalogue

---

E0.109.0219.02.00IM03



hydrotop.ir

**GEAR PUMPS**

SALAMI gear pumps are available with displacements from 1.4 cm<sup>3</sup>/rev to 99 cm<sup>3</sup>/rev (*from 0.09 cu.in/rev to 6.03 cu.in/rev*).

Multiple pumps can always be realized combining stages taken from different or same series.

Several options of shafts, flanges and ports as for European, German and American standards are available for all the pumps.

SALAMI gear pumps offer:

- High volumetric efficiency thanks to an innovative design and an accurate control of machining tolerances.
- Axial compensation achieved by the use of floating bushes that allow high volumetric efficiency throughout the working pressure range.
- DU bearings to ensure high pressure capability.
- 12 teeth integral gear and shaft.
- Aluminium body.
- Cast iron flange and cover.
- Double shaft seals.
- Nitrile seals as standard and Viton seals in high temperature applications.
- All pumps are hydraulically tested after assembly to ensure the highest standard performance.
- Gear pumps are ideal for mobile equipment including: snow plows, light duty equipment, farm vehicles, town trucks, cherry pickers, lift gates, utility vehicles, aerial devices, hoists, spreaders, fan drive.
- Also available Bidirectional rotation.

**WORKING CONDITIONS**

- Pump inlet pressure (absolute pressure)	0.8 to 1.5 bar (11.6 to 21.7 psi)
- Minimum operating fluid viscosity	12 mm <sup>2</sup> / sec
- Max starting viscosity	800 mm <sup>2</sup> / sec
- Suggested fluid viscosity range	17 - 65 mm <sup>2</sup> / sec
- Fluid operating temperature range	-20 to 80 °C
- Fluid operating temperature range with FPM seals (Viton)	-15 to 110°C
- Fluid operating temperature range with HNBR seals*	-30 to 110°C
- Hydraulic fluid	Mineral oil according to DIN 51524. Other hydraulic fluids on request.

\*Available on request.

**DEFINITION OF PRESSURES**

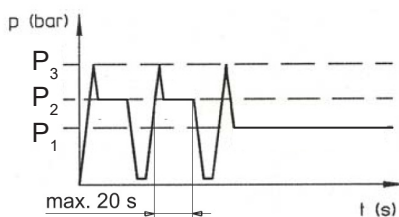

$P_3$  = Peak pressure

$P_2$  = Intermittent operating pressure (1/3 of working time)

$P_1$  = Continuous operating pressure

EO.100.0821.02.001M03



### DRIVE SHAFTS

Radial and axial loads on the shafts must be avoided since they reduce the life of the unit. In order to avoid misalignment during the assembly with the primary engine, a connection with “Oldham” coupling (or coupling having convex toothed hub) is recommended.

### ROTATION

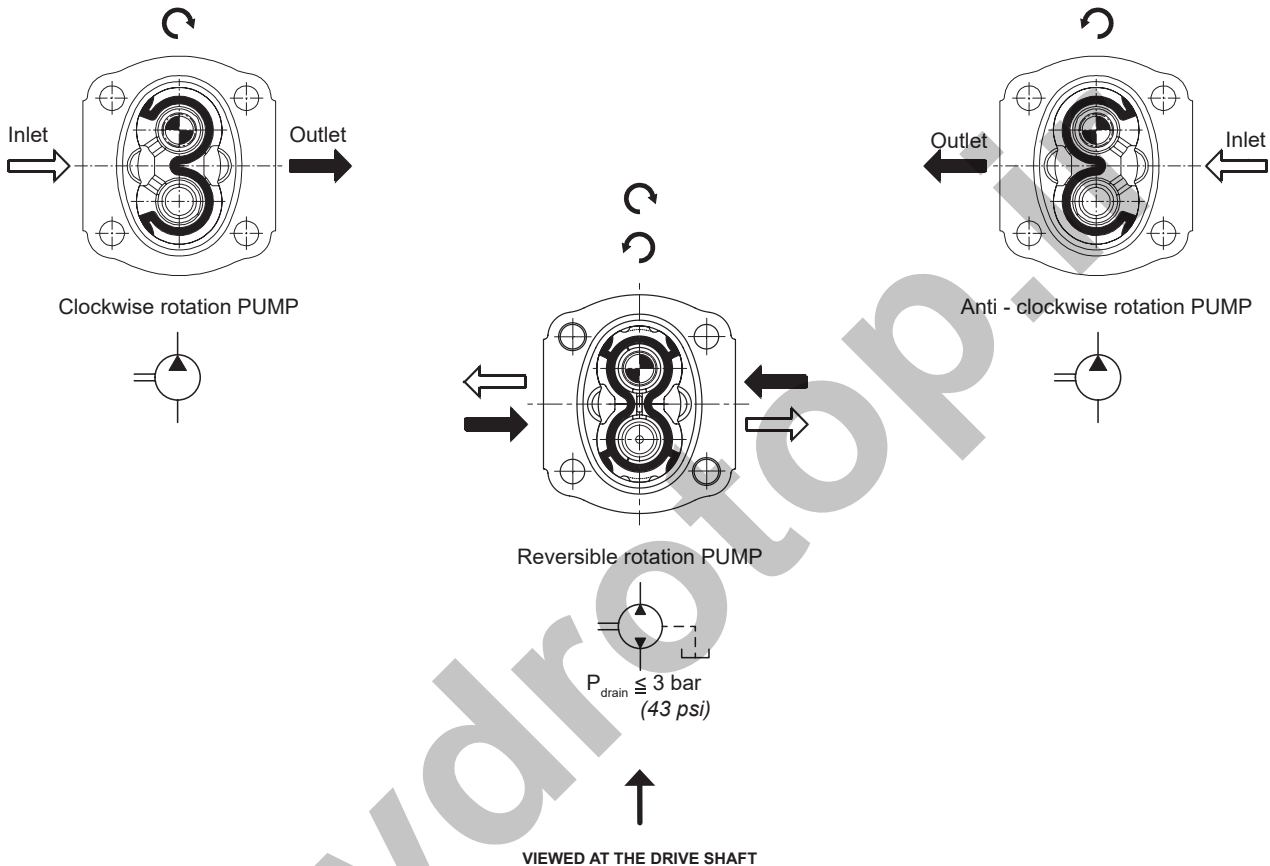

### HYDRAULIC PIPE LINE

To ensure favorable suction conditions it is important to keep pressure drop in suction pipe line to a minimum value (see TECHNICAL DATA). To calculate hydraulic pipe line size, the designer can use; as an approximate guide, the following fluid speed figures:

From 1 to 2 m/sec on suction pipe line  
From 6 to 10 m/sec on pressure pipe line

From 3.28 to 6.36 ft/sec on suction pipe line  
From 19.7 to 32.8 ft/sec on pressure pipe line

The lowest fluid speed values in pipe lines is recommended when the operating temperature range is high and/or for continuous duty.

The highest value is recommended when the temperature difference is low and/or for intermittent duty.

When tandem pumps are supplied by 2 different reservoirs with 2 different fluids it is necessary to specify “AS” version.

**FILTRATION INDEX RECOMMENDED**

Working pressure	>200 bar/2900 psi	<200 bar/2900 psi
Contamination class NAS 1638	9	10
Contamination class ISO 4406	19/18/15	20/19/16
Achieved with filter $\beta_x=75$	15 $\mu\text{m}$	25 $\mu\text{m}$

**COMMON FORMULAS FOR PUMPS**

$$C = \text{Input torque} = \frac{q \cdot \Delta p}{62.8 \cdot \eta_m} \text{ (Nm)}$$

$$P = \text{Input power} = \frac{q \cdot n \cdot \Delta p \cdot 10^{-3}}{600 \eta_m} \text{ (kW)}$$

$$Q = \text{Outlet flow} = \frac{q \cdot n \cdot \eta_v}{1000} \text{ (l/min)}$$

LEGENDA

$\Delta p$  = Working pressure (bar)

$q$  = Displacement ( $\text{cm}^3/\text{rev}$ )

$n$  = Speed ( $\text{min}^{-1}$ )

$\eta_m$  = Mechanical eff. (0.92)

$\eta_v$  = Volumetric eff. (0.95)

**IDENTIFICATION LABEL**

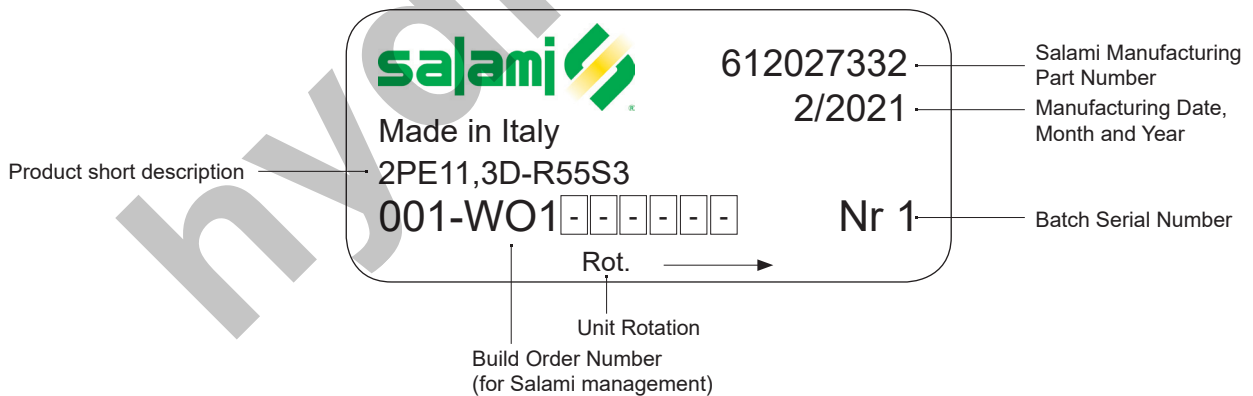

EO.100.0821.02.001M03

### TECHNICAL DATA

GROUP 1.5 - E SERIES	Displacement		Continuous pressure P <sup>1</sup>		Intermittent pressure P <sup>2</sup>		Peak pressure P <sup>3</sup>		Max. speed	Min. speed
	cm <sup>3</sup> /rev	cu.in/rev	bar	psi	bar	psi	bar	psi	rpm	
1.5PE - 1.4	1.4	0.09	250	3625	270	3915	290	4205	5000	700
1.5PE - 2.1	2.1	0.13	250	3625	270	3915	290	4205	5000	700
1.5PE - 2.8	2.8	0.17	250	3625	270	3915	290	4205	4500	700
1.5PE - 3.5	3.5	0.21	250	3625	270	3915	290	4205	4500	700
1.5PE - 4.1	4.1	0.25	250	3625	270	3915	290	4205	4000	700
1.5PE - 5.2	5.2	0.32	230	3335	250	3625	270	3915	4000	700
1.5PE - 6.2	6.2	0.38	230	3335	250	3625	270	3915	3600	600
1.5PE - 7.6	7.6	0.46	200	2900	220	3190	250	3625	3300	600
1.5PE - 9.3	9.3	0.57	180	2610	200	2900	240	3480	3000	600
1.5PE - 11	11	0.67	170	2465	190	2755	220	3190	3000	600

GROUP 2 - E SERIES	cm <sup>3</sup> /rev	cu.in/rev	bar	psi	bar	psi	bar	psi	rpm	
2PE - 3.2*	3.2	0.19	250	3625	280	4060	300	4350	4000	600
2PE - 3.9*	3.9	0.24	250	3625	280	4060	300	4350	4000	600
2PE - 4.5	4.6	0.27	250	3625	280	4060	300	4350	4000	600
2PE - 6.5	6.5	0.4	250	3625	280	4060	300	4350	4000	600
2PE - 8.3	8.2	0.5	250	3625	280	4060	300	4350	3500	500
2PE - 10.5	10.6	0.65	250	3625	280	4060	300	4350	3500	500
2PE - 11.3	11.5	0.68	250	3625	280	4060	300	4350	3500	500
2PE - 12.5	12.7	0.77	250	3625	280	4060	300	4350	3500	500
2PE - 13.8	13.8	0.84	250	3625	280	4060	300	4350	3500	500
2PE - 16	16.6	1.01	250	3625	280	4060	300	4350	3000	400
2PE - 19	19.4	1.15	220	3190	240	3480	260	3750	3000	400
2PE - 22.5	22.9	1.37	200	2900	220	3190	240	3480	2750	400
2PE - 26	26.6	1.62	180	2610	200	2900	220	3190	2500	400

\*Available only as rear pump

GROUP 2.5 - B SERIES	cm <sup>3</sup> /rev	cu.in/rev	bar	psi	bar	psi	bar	psi	rpm	
2.5PB - 5.5*	5.97	0.36	250	3625	280	4060	300	4350	3000	600
2.5PB - 8.3*	8.29	0.50	250	3625	280	4060	300	4350	3000	600
2.5PB - 11.5*	11.76	0.72	250	3625	280	4060	300	4350	3000	600
2.5PB - 13.8*	14.07	0.86	250	3625	280	4060	300	4350	3000	600
2.5PB - 16	16	0.97	250	3625	280	4060	300	4350	3000	600
2.5PB - 19	19.3	1.17	250	3625	280	4060	300	4350	3000	600
2.5PB - 22	22.2	1.35	250	3625	280	4060	300	4350	3000	500
2.5PB - 25	25.2	1.53	250	3625	280	4060	300	4350	3000	500
2.5PB - 28	27.6	1.68	250	3625	280	4060	300	4350	3000	500
2.5PB - 32	32.4	1.97	230	3335	250	3625	260	3750	3000	500
2.5PB - 38	38.1	2.32	200	2900	220	3190	240	3480	2750	400
2.5PB - 44	44.2	2.69	170	2465	190	2755	210	3040	2500	400

\*Available only as rear pump. Displacements 11.5-13.8 are available as single pump only with drive shaft “55”.



**TECHNICAL DATA**

	Displacement		Continuous pressure P <sup>1</sup>		Intermittent pressure P <sup>2</sup>		Peak pressure P <sup>3</sup>		Max. speed	Min. speed
	cm <sup>3</sup> /rev	cu.in/rev	bar	psi	bar	psi	bar	psi		
<b>GROUP 3 - E SERIES</b>									rpm	
3PE - 21	20.6	1.26	250	3625	280	4060	300	4350	3000	600
3PE - 27	27	1.65	250	3625	280	4060	300	4350	3000	600
3PE - 33	33.5	2.04	250	3625	280	4060	300	4350	3000	600
3PE - 38	38.7	2.36	250	3625	280	4060	300	4350	2750	500
3PE - 46	46.9	2.86	250	3625	270	3915	280	4060	2750	500
3PE - 55	54.1	3.3	220	3190	240	3480	250	3625	2500	400
3PE - 65	63.1	3.85	200	2900	220	3190	240	3480	2500	400
3PE - 75	73.4	4.48	180	2610	200	2900	220	3190	2500	400

	Displacement		Continuous pressure P <sup>1</sup>		Intermittent pressure P <sup>2</sup>		Peak pressure P <sup>3</sup>		Max. speed	Min. speed
	cm <sup>3</sup> /rev	cu.in/rev	bar	psi	bar	psi	bar	psi		
<b>GROUP 3.5 - C SERIES</b>									rpm	
3.5PC - 55	54.8	3.34	250	3625	280	4060	300	4350	2750	400
3.5PC - 64	63.2	3.85	250	3625	280	4060	300	4350	2750	350
3.5PC - 75	74.7	4.55	230	3335	250	3625	280	4060	2500	300
3.5PC - 87	88	5.36	210	3040	230	3330	260	3750	2250	300
3.5PC - 98*	99	6.03	200	2900	220	3190	250	3625	2000	300

\*Displacement 98 are special release, please contact sales department.

- ⚠ *Max Speed must be lowered by 10% for system working continuously at p<sup>1</sup> pressure.  
Max pressure must be lowered by 10% for bi-directional pump.*

### ROTATION CHANGING INSTRUCTIONS FOR UNITS

Keep the working surface cleaned as well as the exterior of the pump before starting and avoid inner contamination of the pump. The pump shown below is a clockwise rotating pump. To achieve anti-clockwise rotation, please read the following instructions carefully.

#### CLOCKWISE ROTATION

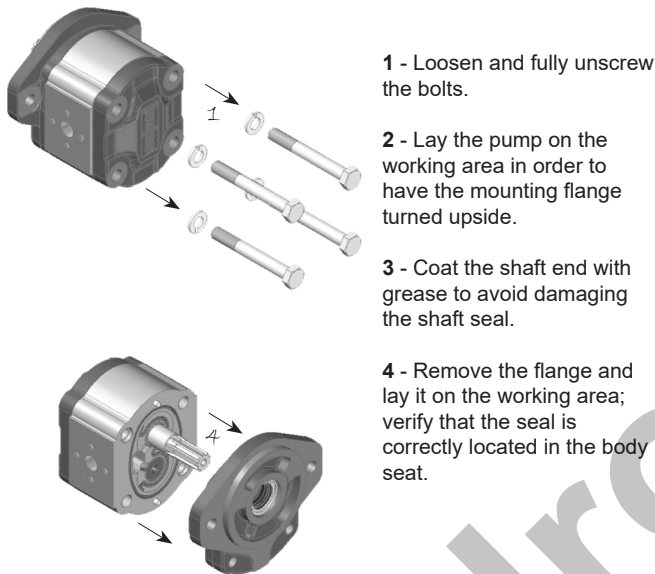

**1** - Loosen and fully unscrew the bolts.

**2** - Lay the pump on the working area in order to have the mounting flange turned upside.

**3** - Coat the shaft end with grease to avoid damaging the shaft seal.

**4** - Remove the flange and lay it on the working area; verify that the seal is correctly located in the body seat.

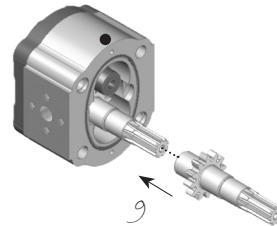

**9** - Re-locate the driving gear in the position previously occupied by the driven gear.

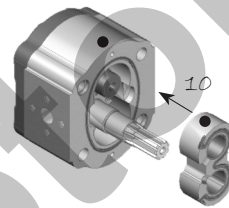

**10** - Replace the bushing and thrust plate taking care that:  
- marks are located as on the picture  
- surface containing the seal is visible  
- seal and its protection are correctly located.

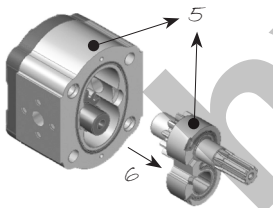

**5** - Mark the position of the bushing and eventually of the thrust plate, as well, with reference to the body.

**6** - Remove the bushing, thrust plate and the driving gear taking care to avoid driven gear axial shifts.

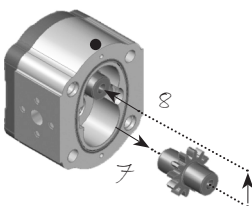

**7** - Draw out the driven gear from its housing, taking care to avoid rear cover axial shifts.

**8** - Re-locate the driven gear in the position previously occupied by the driving gear.

**11** - Clean the body and mounting flange facing surfaces.

**12** - Verify that the two plugs are located in the body.

**13** - Refit the mounting flange, turned 180° from its original position.

**14** - Replace the bolts and tighten clockwise evenly to an appropriate torque.

**15** - Check that the shaft rotates freely.

**16** - Mark on the flange the new direction of rotation.

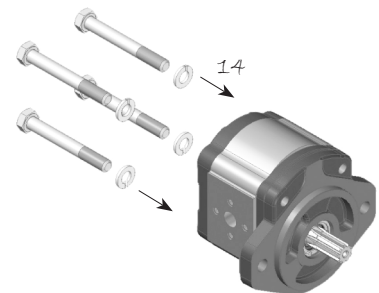

#### ANTI - CLOCKWISE ROTATION





**INDEX**

Shafts And Flanges Combination .....	15
Assembling Dimensions And Working Conditions .....	16
Flanged And Threaded Ports.....	17
Drive Shafts .....	18
Mounting Flanges .....	19
Rear Covers With Relief Valve .....	20
Multiple Gear Pumps Assembling Dimensions.....	21
Performance Curves.....	22
How To Order Single Pumps .....	27
How To Order Multiple Pumps.....	28

hydrotop.ir

**Final revised edition** - February 2019





The data in this catalogue refers to the standard product.

The policy of Salami S.p.A. consists of a continuous improvement of its products. It reserves the right to change the specifications of the different products whenever necessary and without giving prior information.

***If any doubts, please contact our sales department.***

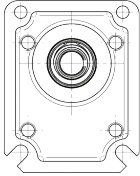
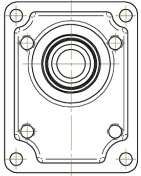
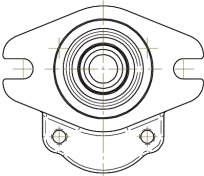
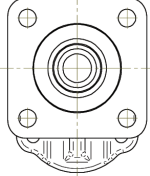
hydrotop.ir

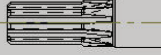
**SHAFTS AND FLANGES COMBINATION**

<p><b>1.5PE</b></p>	 CODE <b>P0</b> - (Ø25,4 mm) European standard	 CODE <b>P01</b> - (Ø30 mm) European standard	 CODE <b>S0</b> - SAE AA 2 bolts	 CODE <b>S1</b> - SAE AA 4 bolts
 CODE <b>18</b> - Tapered 1:8	18P0			
 CODE <b>19</b> - Tapered 1:8		19P01		
 CODE <b>51</b> - SAE A Splined 9T			51S0	
 CODE <b>80</b> - SAE AA Parallel Ø12,7			80S0	
 CODE <b>83</b> - SAE Parallel Ø12,7				83S1

EO.109.0219.02.001M02

Displacements up to 0.67 cu.in./rev  
Pressure up to 4205 psi



GEAR PUMPS

Displacements up to 11 cm<sup>3</sup>/rev  
Pressure up to 290 bar

### ASSEMBLING DIMENSIONS AND WORKING CONDITIONS

Type		1.4	2.1	2.8	3.5	4.1	5.2	6.2	7.6	9.3	11
Displacement	cm <sup>3</sup> /rev	1.4	2.1	2.8	3.5	4.1	5.2	6.2	7.6	9.3	11
	cu.in./rev	0.09	0.13	0.17	0.21	0.25	0.32	0.38	0.46	0.57	0.67
Dimension A	mm	44	45.9	47.9	49.9	51.6	54.7	57.5	61.5	66.3	71.1
	in	1.73	1.81	1.89	1.96	2.03	2.15	2.26	2.42	2.61	2.80
Dimension C	mm	22	22.95	23.95	24.95	25.8	27.35	28.75	30.75	33.15	35.55
	in	0.87	0.90	0.94	0.98	1.02	1.08	1.13	1.21	1.31	1.40
Continuous pressure*	P <sup>1</sup>	bar	250	250	250	250	230	230	200	180	170
		psi	3625	3625	3625	3625	3335	3335	2900	2610	2465
Intermittent pressure	P <sup>2</sup>	bar	270	270	270	270	250	250	220	200	190
		psi	3615	3615	3615	3615	3625	3625	3190	2900	2755
Peak pressure	P <sup>3</sup>	bar	290	290	290	290	290	270	270	240	220
		psi	4205	4205	4205	4205	4205	3915	3915	3925	3480
Max speed		rpm	5000	5000	4500	4500	4000	4000	3600	3300	3000
Min speed		rpm	700	700	700	700	700	600	600	600	600
Weight		kg	1.25	1.27	1.30	1.34	1.37	1.42	1.45	1.52	1.59
		lbs	2.76	2.80	2.87	2.94	3.02	3.13	3.20	3.35	3.66

\*For working conditions, using exclusively pressure P<sup>1</sup>, the value of max. speed must be reduced of 10%.

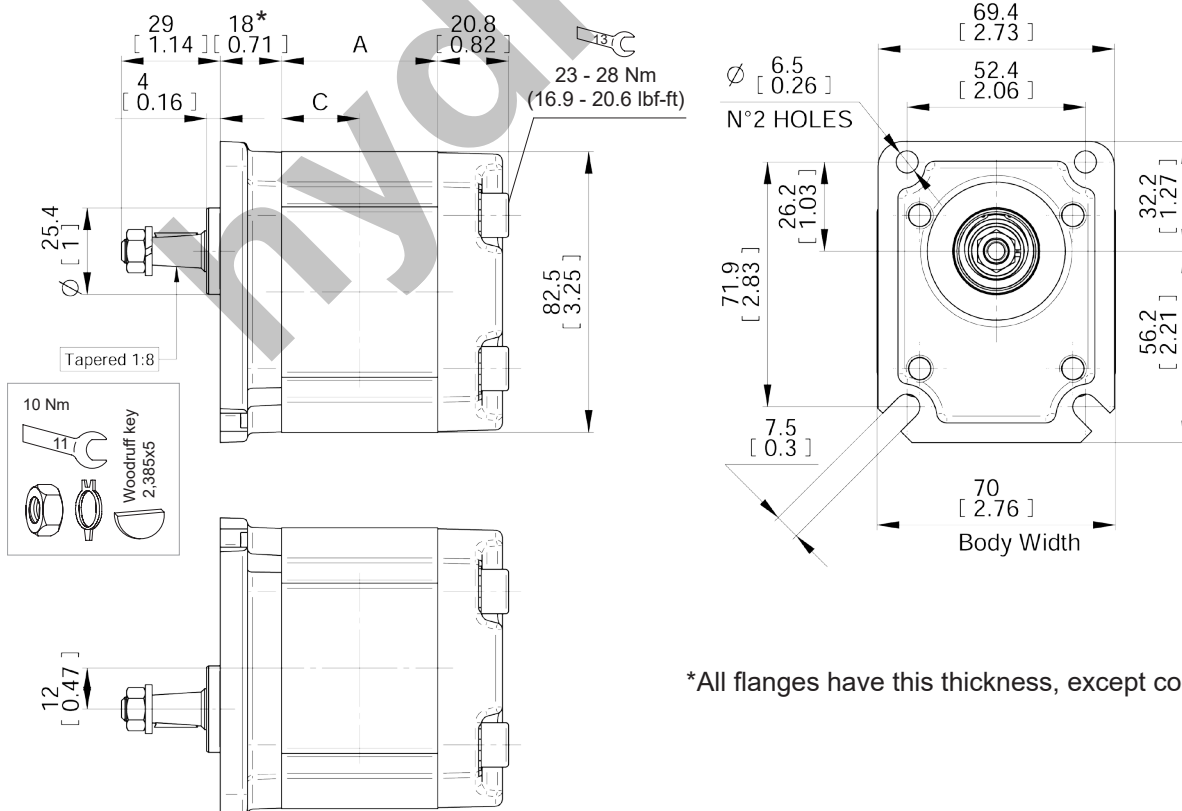

\*All flanges have this thickness, except code S1.

E0.109.0219.02.001M03



**FLANGED AND THREADED PORTS**

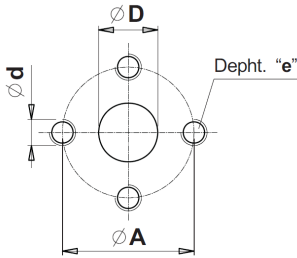

**code P**

Flanged ports  
european standard

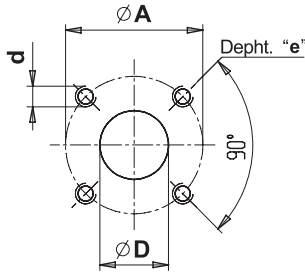

**code B**

Flanged ports  
german standard

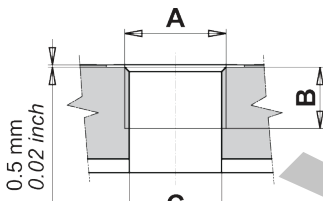

**code G**

Threaded ports  
GAS (BSPP)

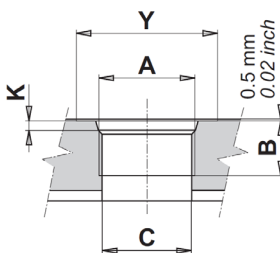

**code R**

Threaded ports  
SAE (ODT)



UNI-DIRECTIONAL PUMP	TYPE	INLET				OUTLET			
		Ø D	Ø A	d	e	Ø D	Ø A	d	e
	From 1.4 to 11	12 (0.47")	30 (1.18")	M6	13 (0.51")	12 (0.47")	30 (1.18")	M6	13 (0.51")



BI-DIRECTIONAL PUMPS Special version available on request.



UNI-DIRECTIONAL PUMP	TYPE	INLET				OUTLET			
		Ø D	Ø A	d	e	Ø D	Ø A	d	e
	From 1.4 to 11	12 (0.47")	30 (1.18")	M6	13 (0.51")	12 (0.47")	30 (1.18")	M6	13 (0.51")



BI-DIRECTIONAL PUMPS Special version available on request.



UNI-DIRECTIONAL PUMP	TYPE	INLET			OUTLET		
		A	B	C	A	B	C
	From 1.4 to 6.2	G1/2	15 (0.59")	18 (0.71")	G3/8	13 (0.51")	13 (0.51")
	From 7.6 to 11				G1/2	15 (0.59")	



BI-DIRECTIONAL PUMPS Special version available on request.



UNI-DIRECTIONAL PUMP	TYPE	INLET					OUTLET				
		A	B	C	Y	K	A	B	C	Y	K
	From 1.4 to 6.2	3/4 -16 UNF (SAE 8)	14.5 (0.57")	13 (0.51")	30 (1.18")	2.5 (0.10")	9/16 - 18 UNF (SAE6)	13 (0.51")	25 (0.98")	2.5 (0.10")	
	From 7.6 to 11	7/8 -14 UNF (SAE10)	16.7 (0.66")	20 (0.79")	34 (1.34")	2.5 (0.10")					



BI-DIRECTIONAL PUMPS Special version available on request.

EO.109.0219.02.001M02



### DRIVE SHAFTS

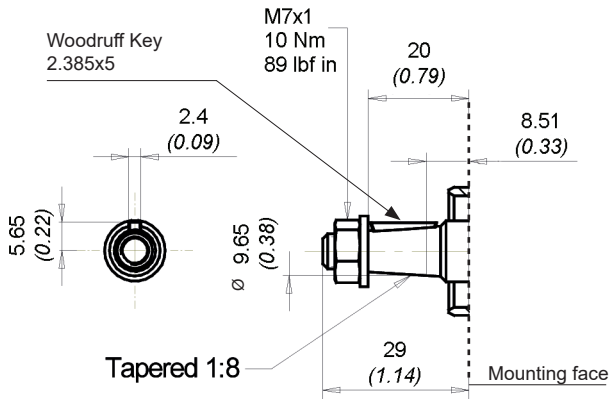

**code 18** Max torque 20 Nm (177 lbf in)  
European Tapered 1:8

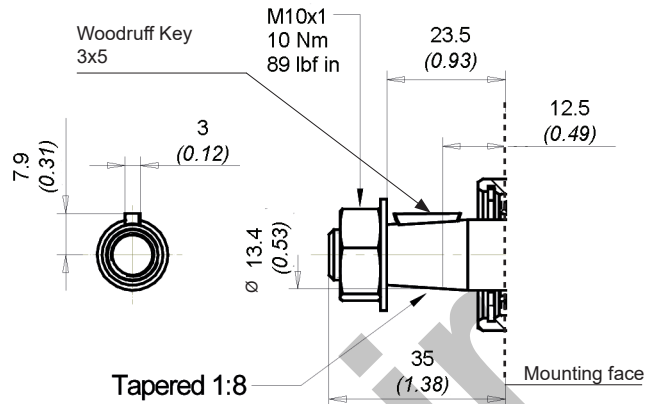

**code 19** Max torque 60 Nm (531 lbf in)  
European Tapered 1:8

Ext. Involute Spline ANSI B92.1  
with major diameter modified  
9 teeth - 20/40 Pitch - 30 deg  
Flat Root - Side fit - Class 5

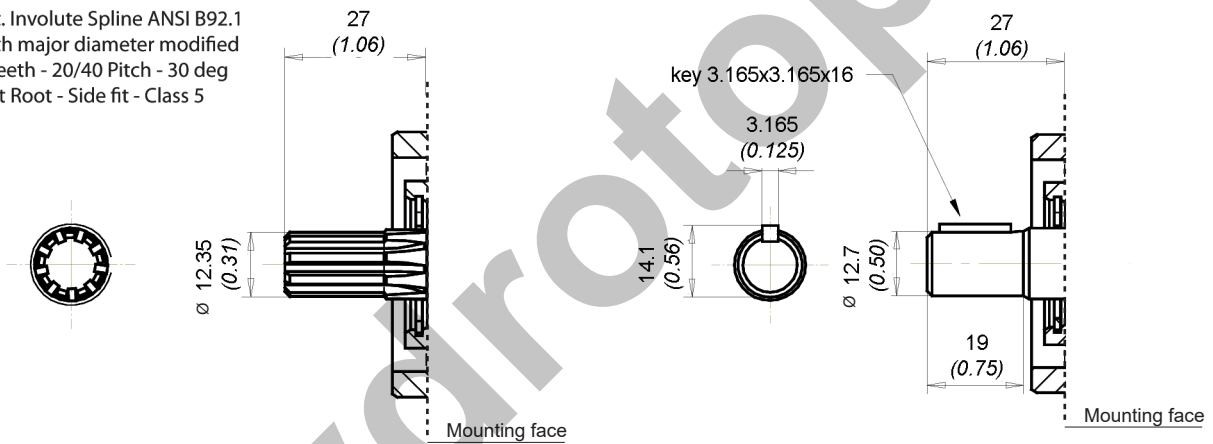

**code 51** Max torque 50 Nm (442 lbf in)  
SAE A Spline 9T

**code 80** Max torque 40 Nm (354 lbf in)  
SAE AA Parallel

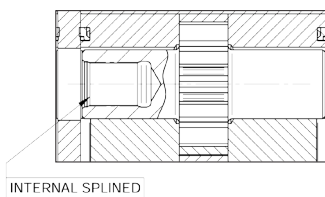

**code 59** Max torque 30 Nm (266 lbf in)  
DIN 5480 internal splined  
(only for rear pumps)

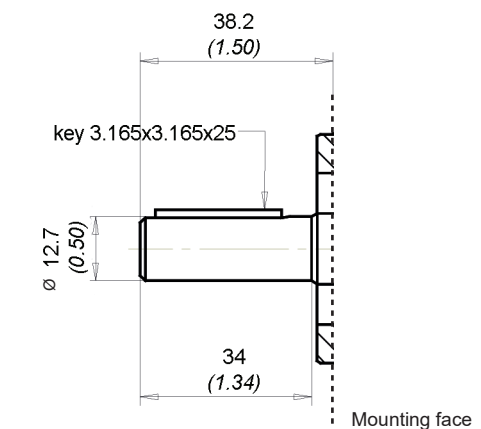
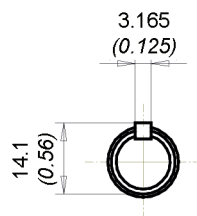

**code 83** Max torque 40 Nm (354 lbf in)  
SAE Parallel

E0.109.0219.02.00IM03



**MOUNTING FLANGES**

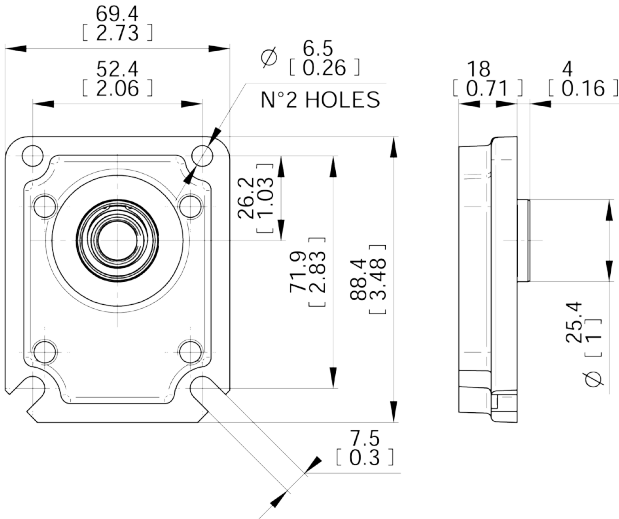

**P0** European standard  
With shaft code 18

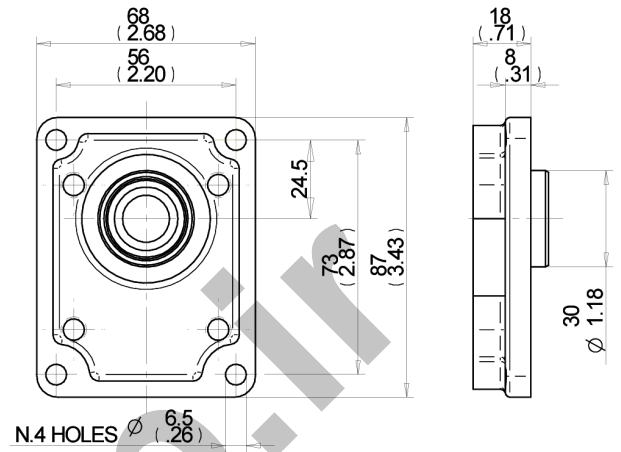

**P01** European standard  
With shaft code 19

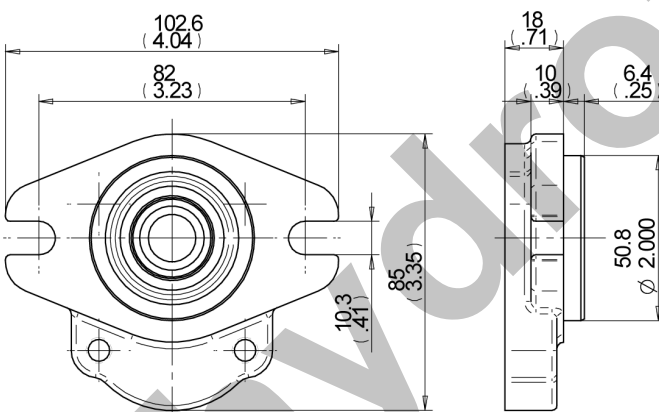

**S0** SAE AA 2 bolts  
With shaft code 51-80

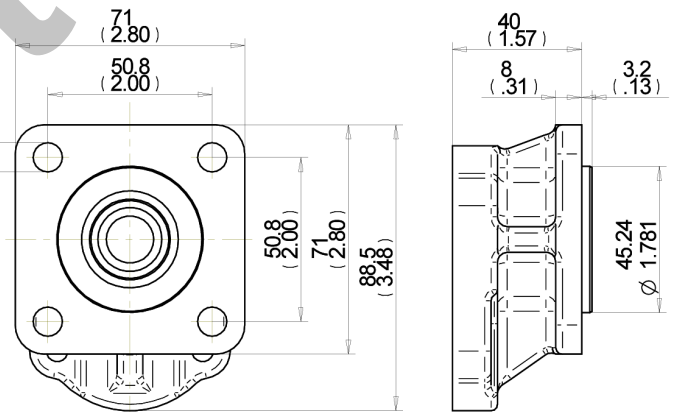

**S1** SAE AA 4 bolts  
With shaft code 83

EO.109.0219.02.001M02

REAR COVERS WITH RELIEF VALVE

code VS

With main relief valve  
with internal unloading line.

Rear cover with fixed setting main relief valve.

Available values of fixed setting from 20 bar to 250 bar/290 psi-3625 psi  
(Standard setting are multiple of 10 bar).

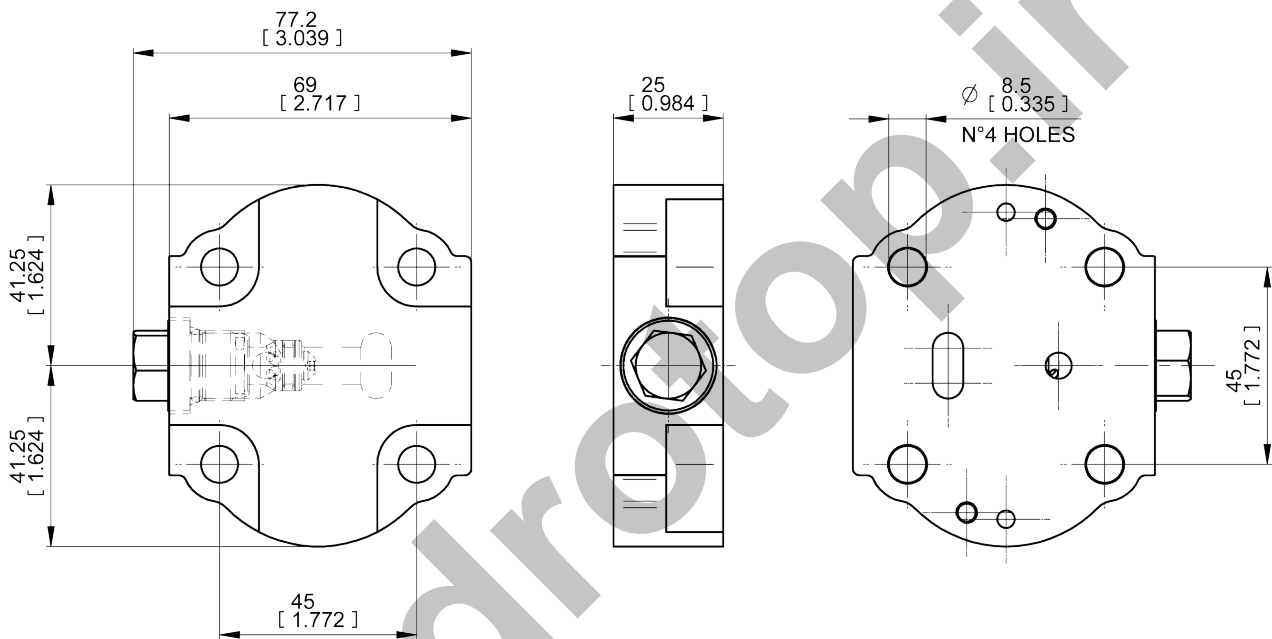
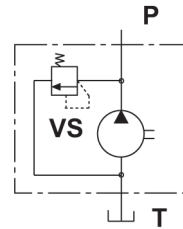

E0.109.0219.02.001M03



**MULTIPLE GEAR PUMPS  
ASSEMBLING DIMENSIONS**

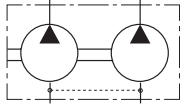

**MULTIPLE GEAR PUMPS with inlet port on each body**

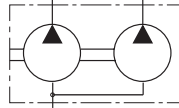

**MULTIPLE GEAR PUMPS with common inlet port\***

\*In case of common inlet port, to avoid too high value of oil speed, 12 l/min is the max sucked flow for the downstream pump.

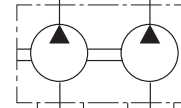

**MULTIPLE GEAR PUMPS with separated stages**

**code AS**

Type		1.4	2.1	2.8	3.5	4.1	5.2	6.2	7.6	9.3	11
Dimension A	mm	44	45.9	47.9	49.9	51.6	54.7	57.5	61.5	66.3	71.1
	in	1.73	1.81	1.89	1.96	2.03	2.15	2.26	2.42	2.61	2.80
Dimension C	mm	22	22.95	23.95	24.95	25.80	27.35	28.75	30.75	33.15	35.55
	in	0.87	0.90	0.94	0.98	1.02	1.08	1.13	1.21	1.31	1.40

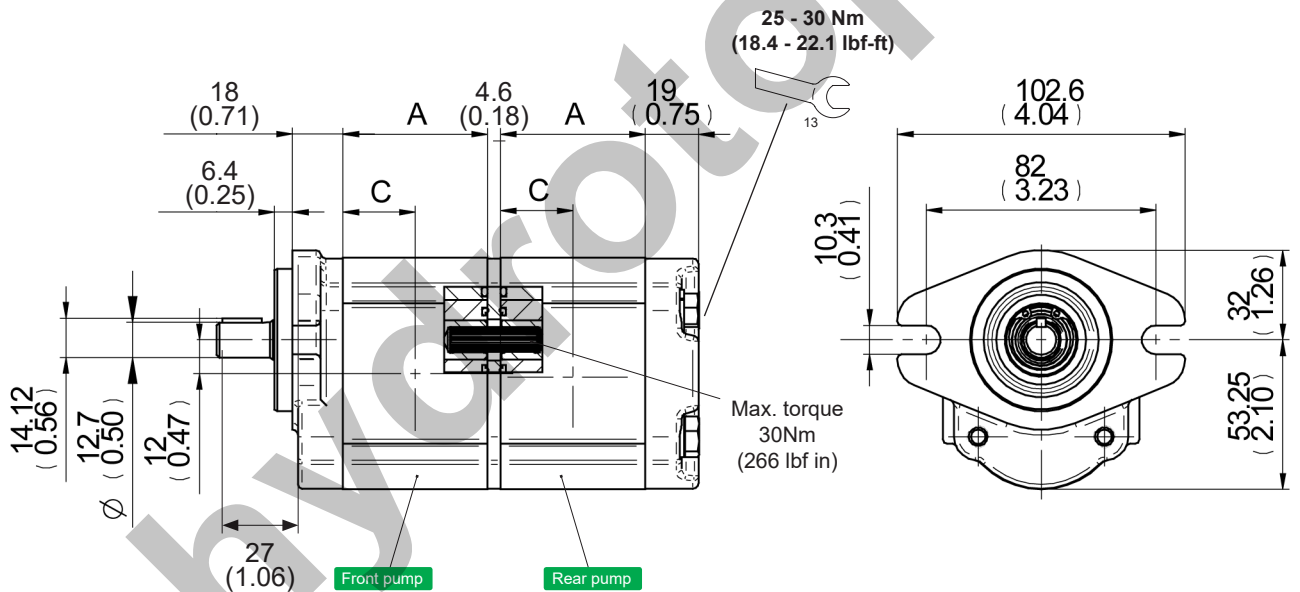

This is a Salami standard pump, alla drive shafts have a splined end. These units are pre-arranged for multiple pumps, they have the drive shaft code 59.

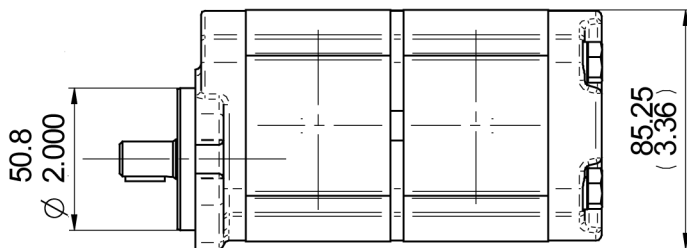

EO.109.0219.02.001M02



### PERFORMANCE CURVES

Performance curves carried out with oil viscosity at 21 cSt and oil temperature at 50°C.  
The performance of these diagrams are approximate. In case you need approved values, please contact our technical department.

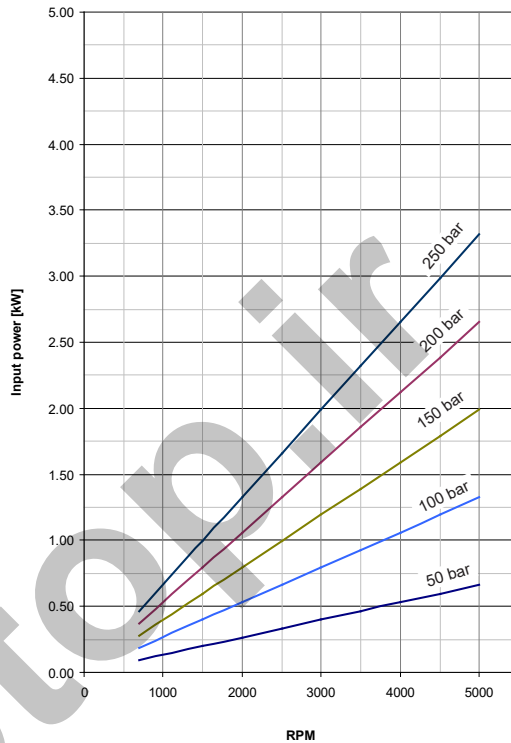
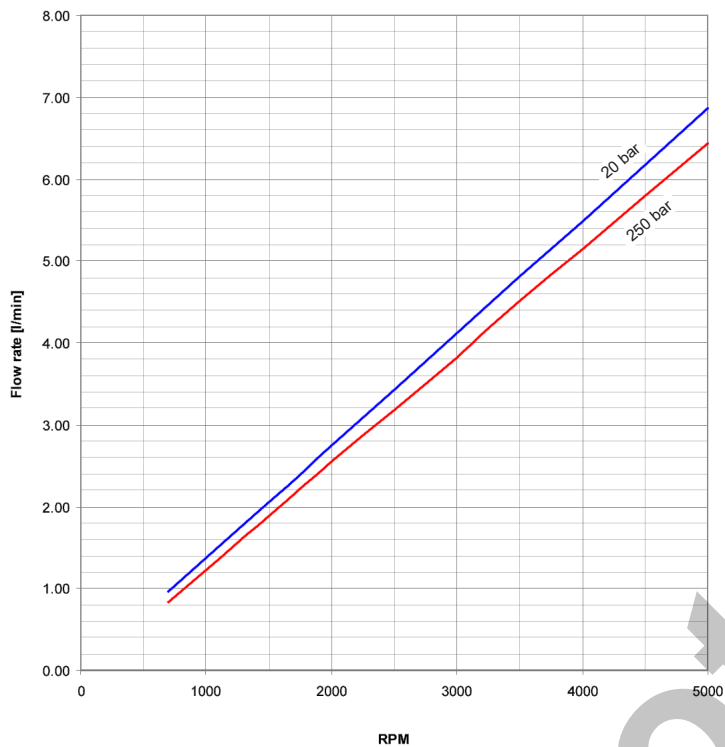

#### 1.5PE - 1.4

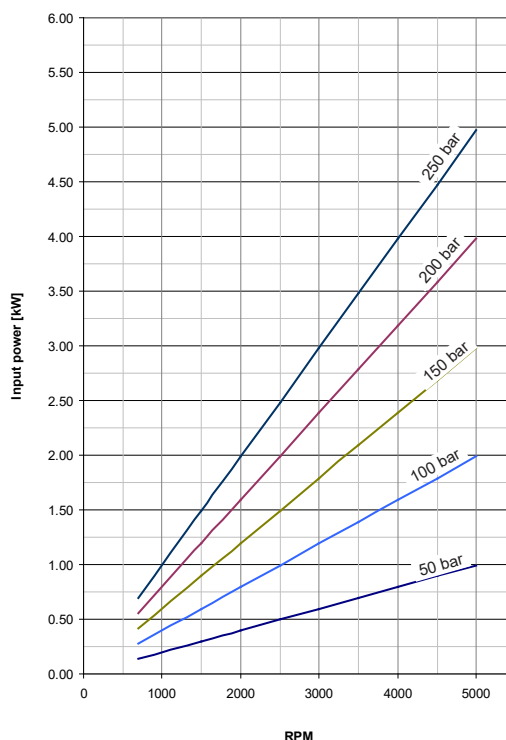
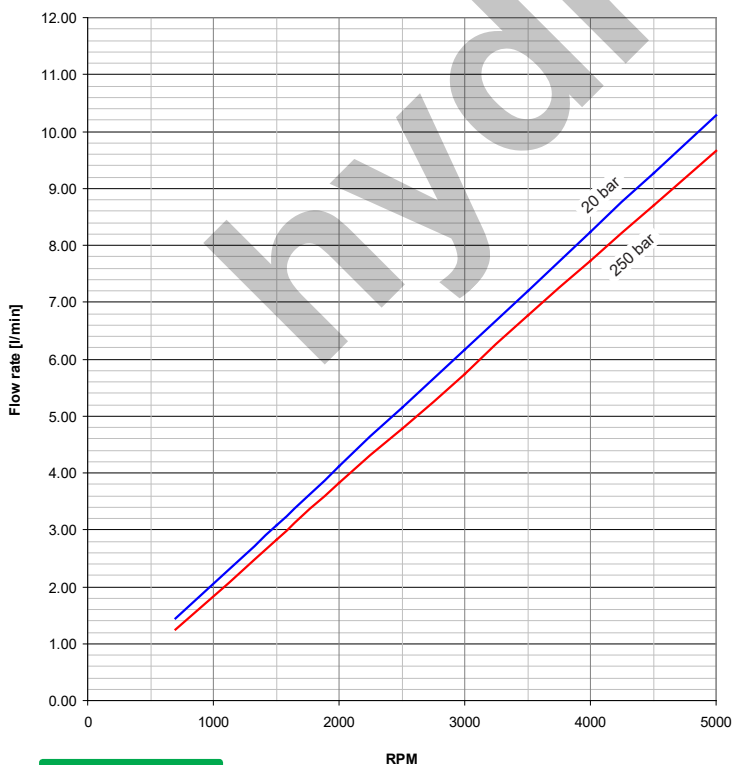

#### 1.5PE - 2.1

**PERFORMANCE CURVES**

Performance curves carried out with oil viscosity at 21 cSt and oil temperature at 50°C.  
The performance of these diagrams are approximate. In case you need approved values, please contact our technical department.

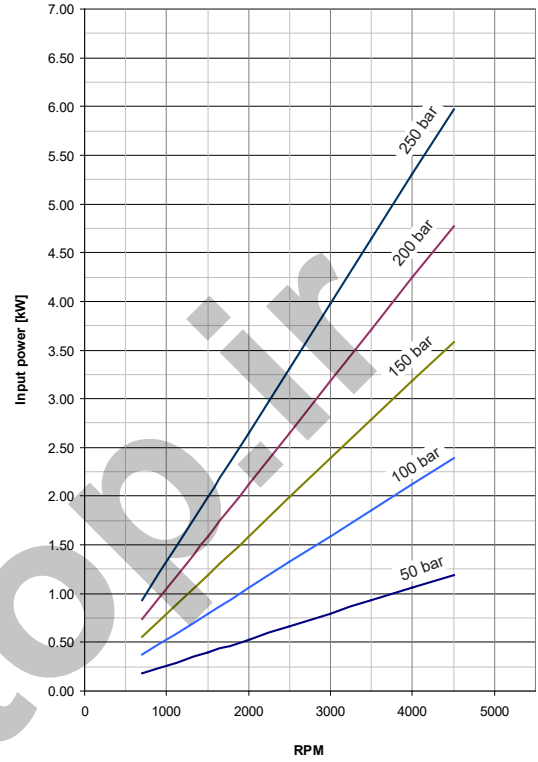
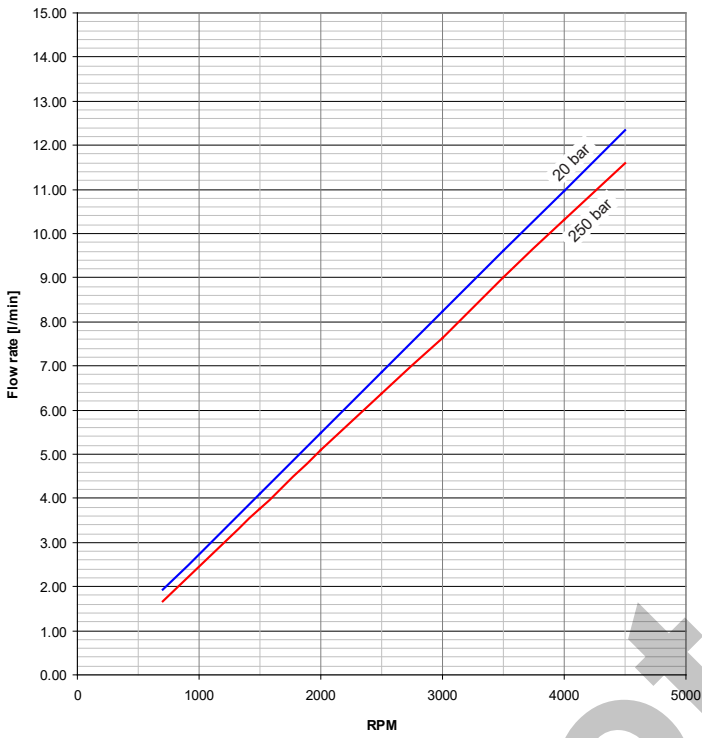

**1.5PE - 2.8**

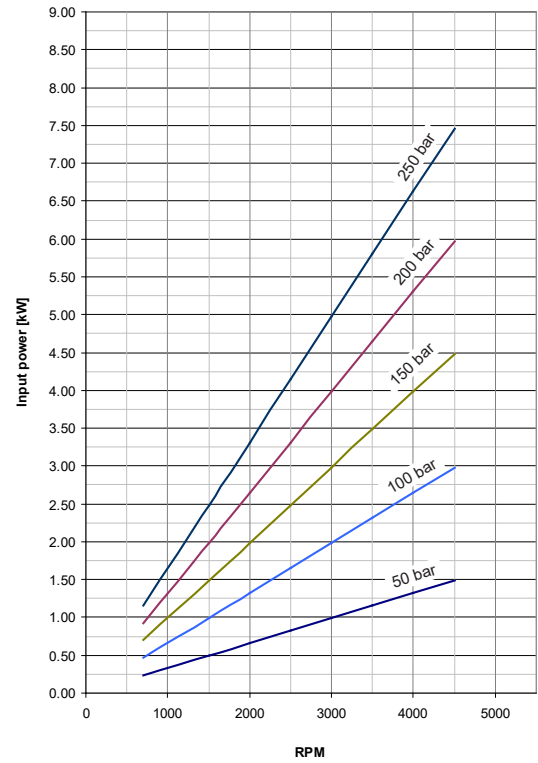
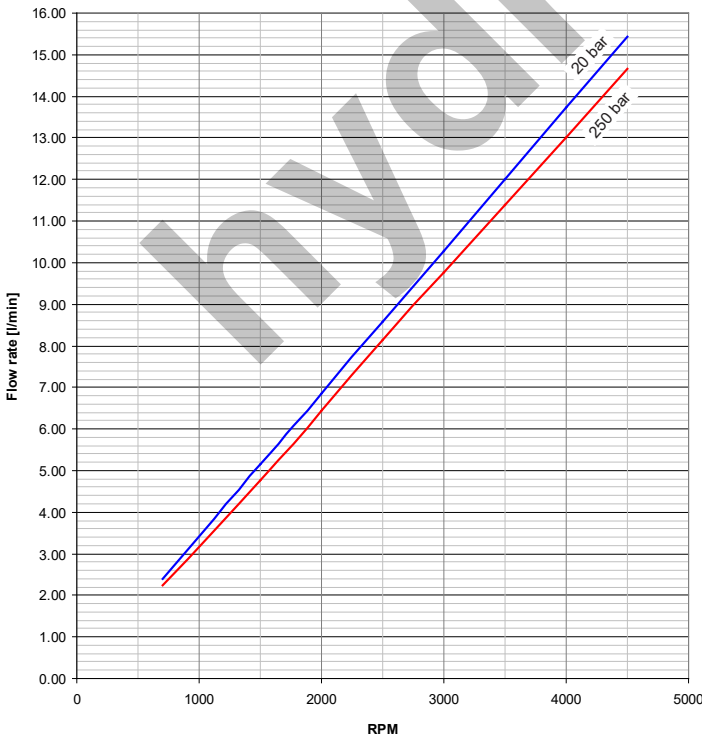

**1.5PE - 3.5**

EO.109.0219.02.001M02



### PERFORMANCE CURVES

Performance curves carried out with oil viscosity at 21 cSt and oil temperature at 50°C.  
The performance of these diagrams are approximate. In case you need approved values, please contact our technical department.

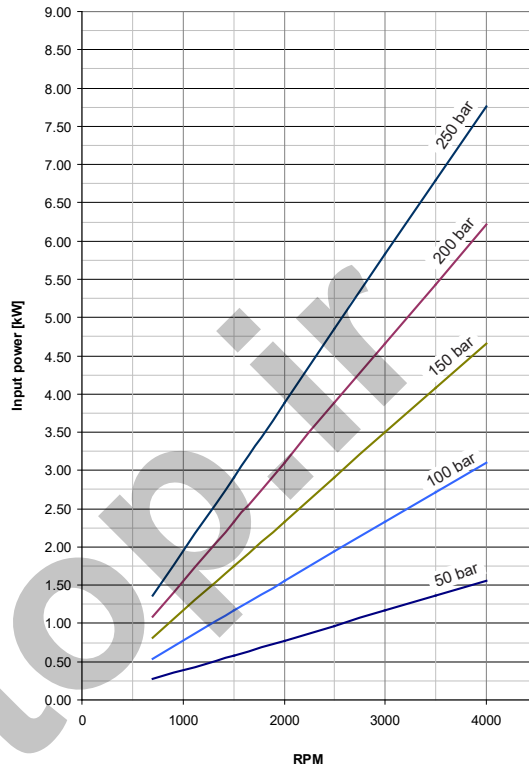
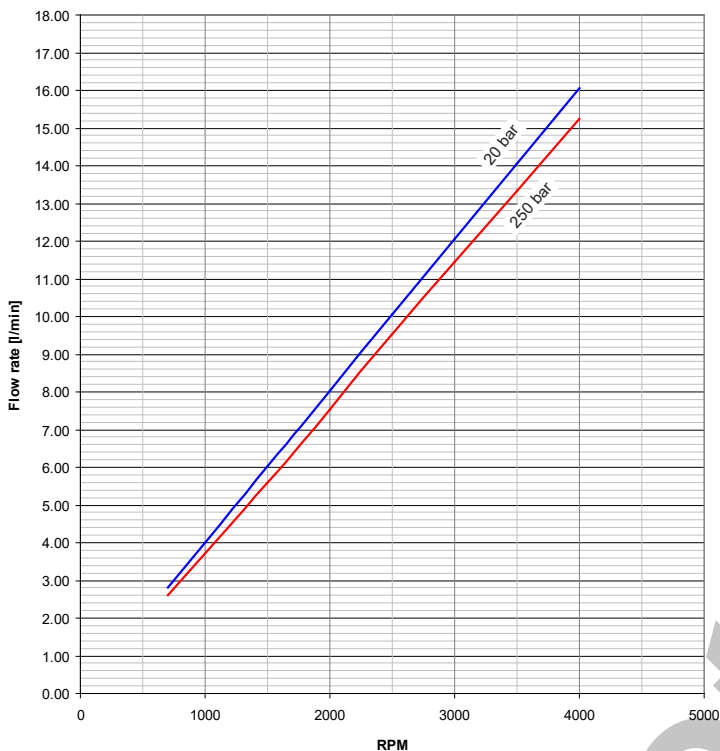

#### 1.5PE - 4.1

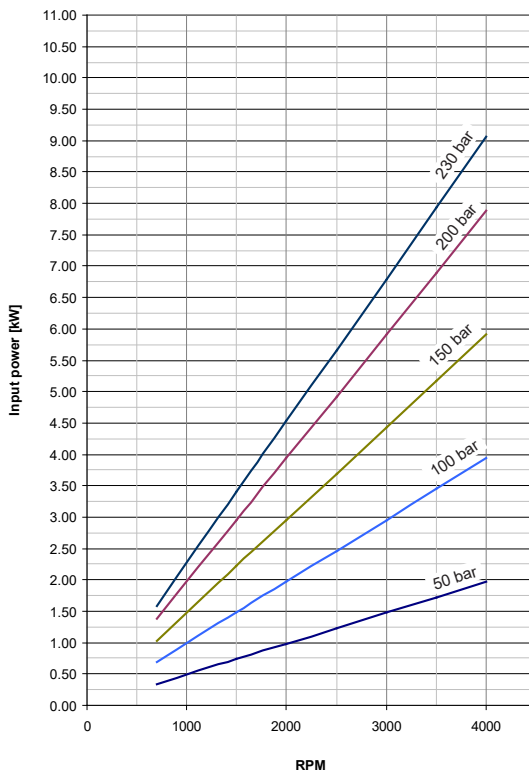
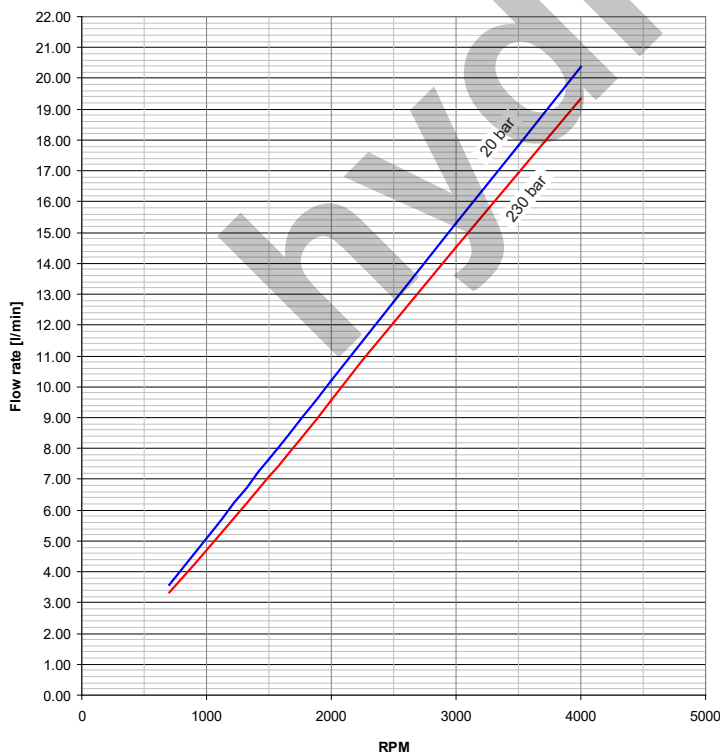

#### 1.5PE - 5.2



**PERFORMANCE CURVES**

Performance curves carried out with oil viscosity at 21 cSt and oil temperature at 50°C.  
The performance of these diagrams are approximate. In case you need approved values, please contact our technical department.

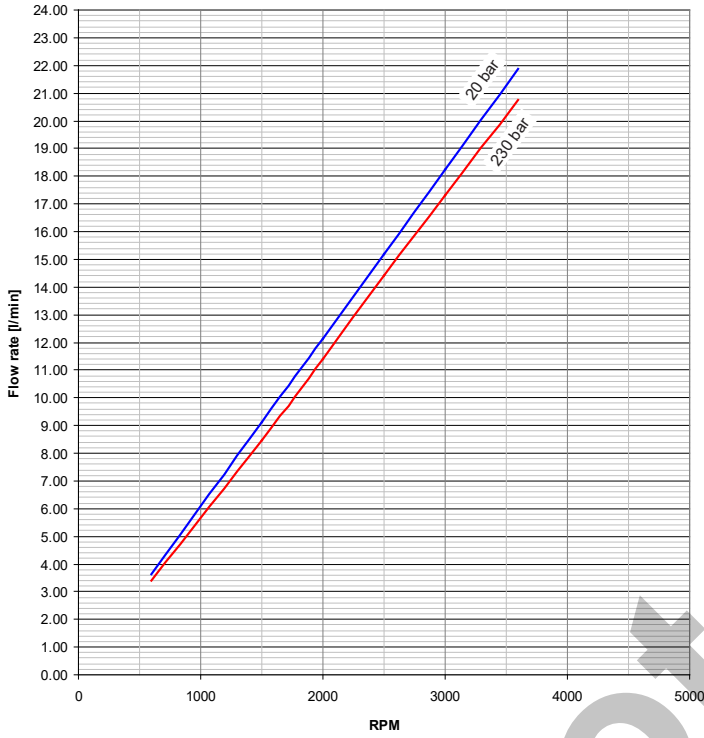

**1.5PE - 6.2**

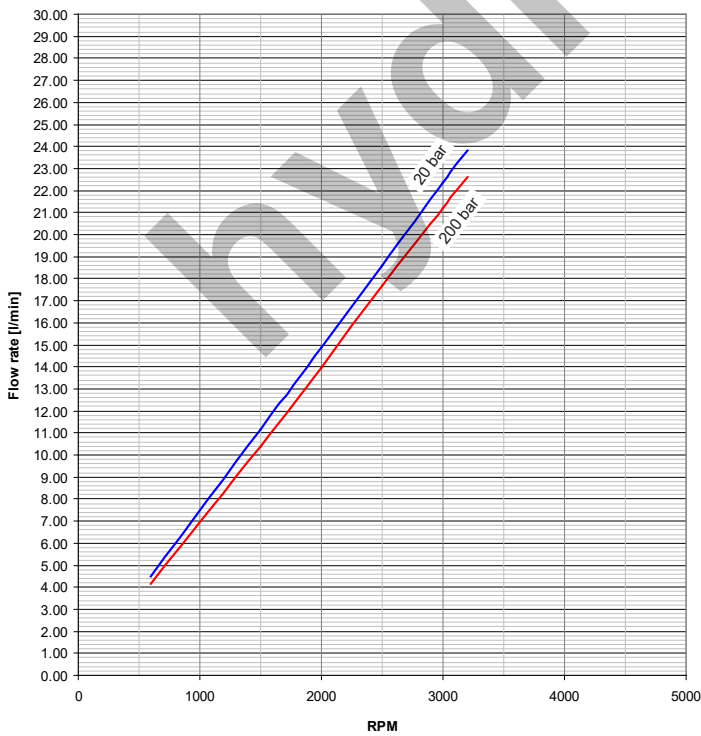
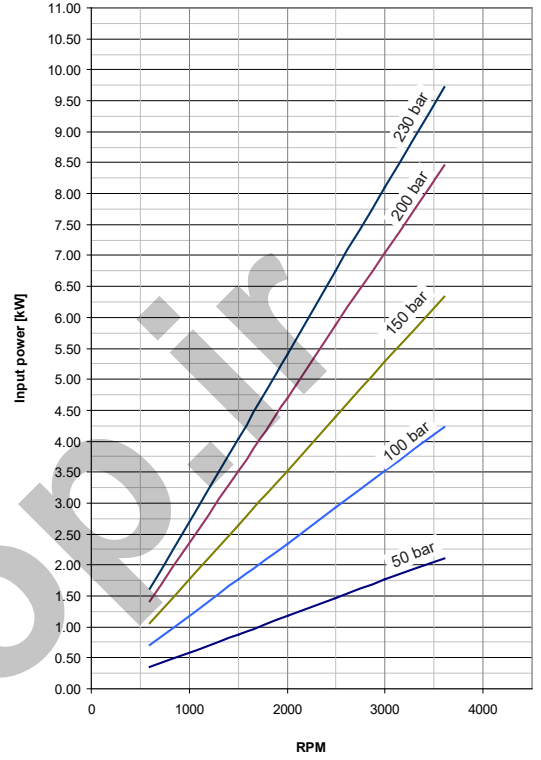

**1.5PE - 7.6**

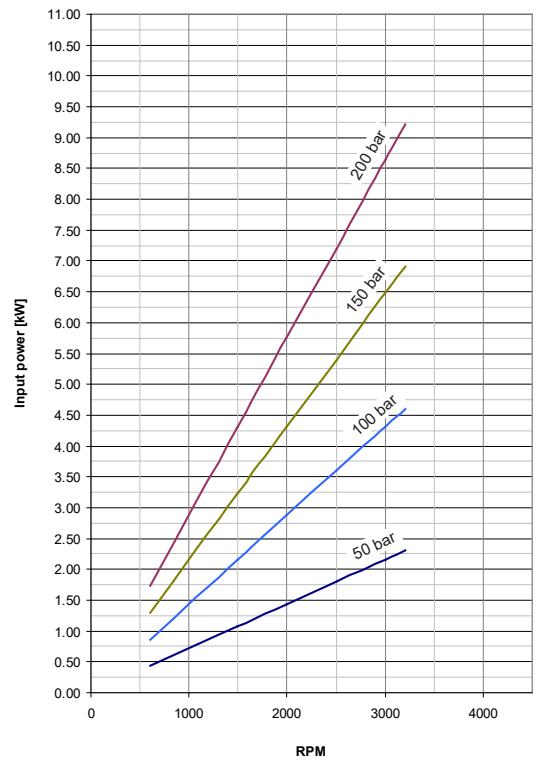

EO.109.0219.02.00IM02



### PERFORMANCE CURVES

Performance curves carried out with oil viscosity at 21 cSt and oil temperature at 50°C.  
The performance of these diagrams are approximate. In case you need approved values, please contact our technical department.

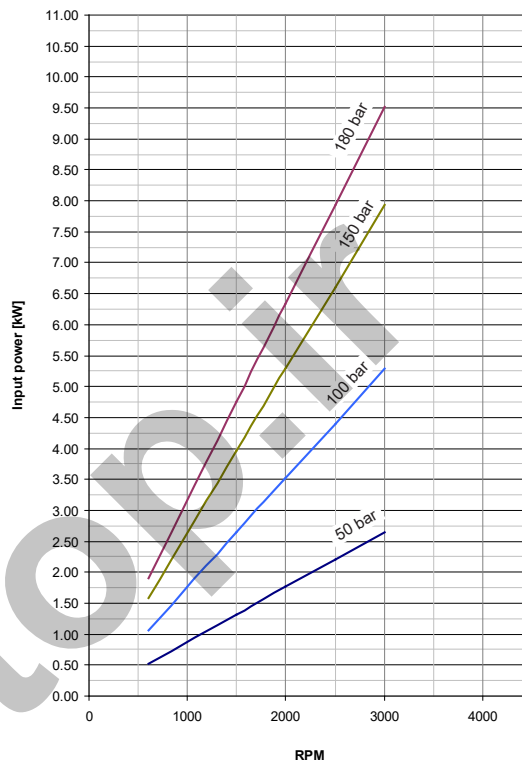
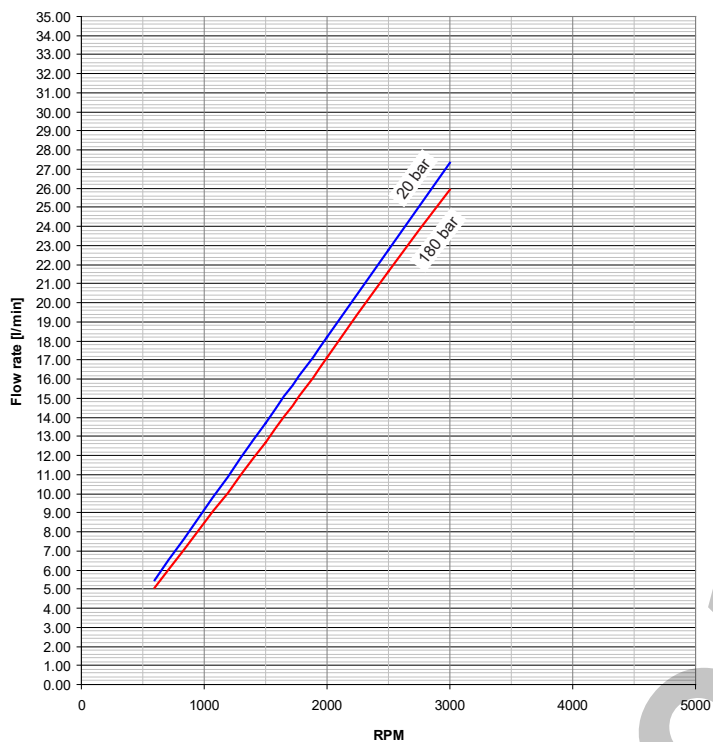

### 1.5PE - 9.3

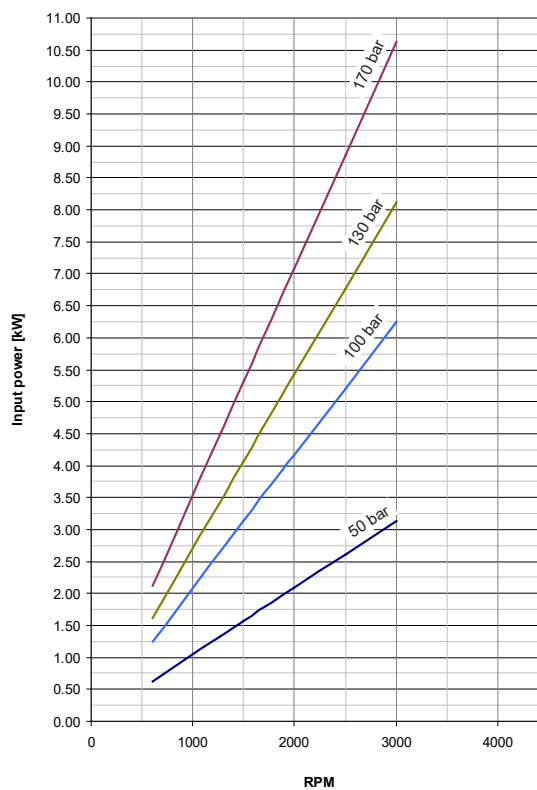
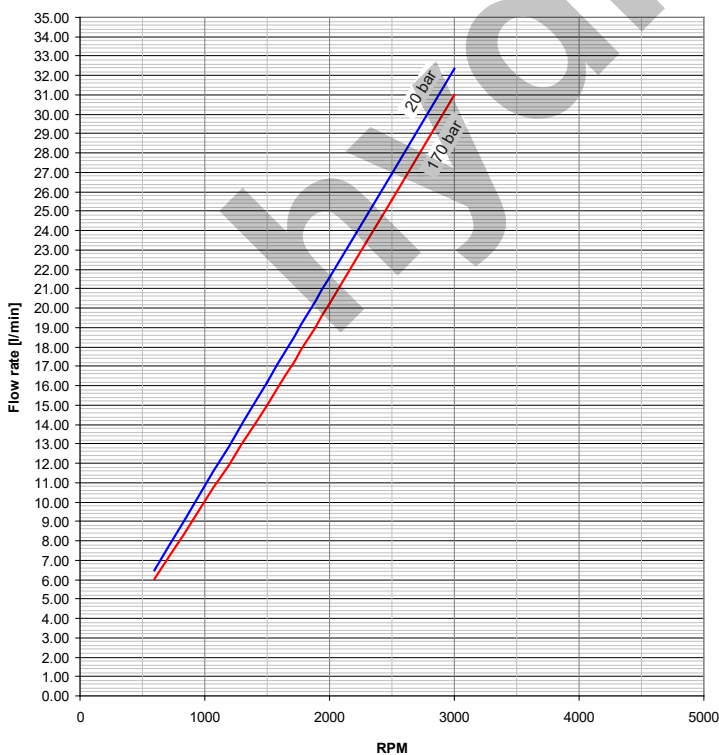

### 1.5PE - 11



**SINGLE PUMPS**

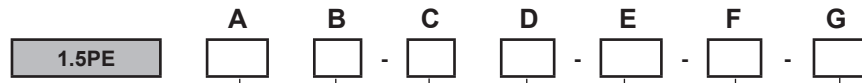

DISPLACEMENTS		CODES	A
1.4 cm <sup>3</sup> /rev.	0.09 cu.in/rev.	1.4	
2.1 cm <sup>3</sup> /rev.	0.13 cu.in/rev.	2.1	
2.8 cm <sup>3</sup> /rev.	0.17 cu.in/rev.	2.8	
3.5 cm <sup>3</sup> /rev.	0.21 cu.in/rev.	3.5	
4.1 cm <sup>3</sup> /rev.	0.25 cu.in/rev.	4.1	
5.2 cm <sup>3</sup> /rev.	0.32 cu.in/rev.	5.2	
6.2 cm <sup>3</sup> /rev.	0.38 cu.in/rev.	6.2	
7.6 cm <sup>3</sup> /rev.	0.46 cu.in/rev.	7.6	
9.3 cm <sup>3</sup> /rev.	0.57 cu.in/rev.	9.3	
11 cm <sup>3</sup> /rev.	0.67 cu.in/rev.	11	

ROTATION (page 132)	CODES	B
Clockwise	D	
Anti-clockwise	S	
Reversible	R	

PORTS (page 141)	CODES	C
Flanged ports european standard	P	
Flanged ports german standard	B	
Threaded ports GAS (BSPP)	G	
Threaded ports SAE (ODT)	R	

DRIVE SHAFTS (page 142)	CODES	D
European Tapered 1:8	18	
European Tapered 1:8	19	
SAE A splined 9T	51	
DIN 5480 internal splined (only for rear pumps- see page 21)	59	
SAE AA parallel Ø12,7	80	
SAE parallel Ø12,7	83	

G	VALVES IN THE COVER (page 20)	CODE
	Fixed main relief valve	VS

F	SEALS	CODE
	Nitrile-butadiene rubber (nbr)	
	Viton	V

E	MOUNTING FLANGES (page 19)	CODES
	European standard	P0
	European standard	P01
	SAE AA (2 bolts)	S0
	SAE AA (4 bolts)	S1

**Order example:** 1.5PE 6.2D, ports European standard (P), drive shaft (51), mounting flange (P0)  
**1.5PE6.2D-P51P0**

EO.109.0219.02.001M02



### MULTIPLE PUMPS

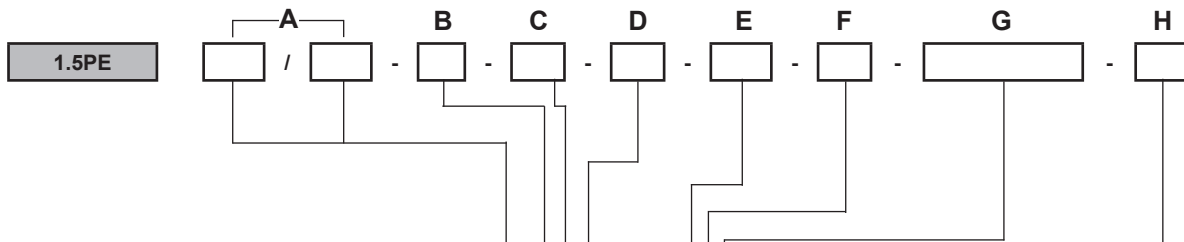

DISPLACEMENTS		CODES	A
1.4 cm <sup>3</sup> /rev.	0.09 cu.in/rev.	1.4	
2.1 cm <sup>3</sup> /rev.	0.13 cu.in/rev.	2.1	
2.8 cm <sup>3</sup> /rev.	0.17 cu.in/rev.	2.8	
3.5 cm <sup>3</sup> /rev.	0.21 cu.in/rev.	3.5	
4.1 cm <sup>3</sup> /rev.	0.25 cu.in/rev.	4.1	
5.2 cm <sup>3</sup> /rev.	0.32 cu.in/rev.	5.2	
6.2 cm <sup>3</sup> /rev.	0.38 cu.in/rev.	6.2	
7.6 cm <sup>3</sup> /rev.	0.46 cu.in/rev.	7.6	
9.3 cm <sup>3</sup> /rev.	0.57 cu.in/rev.	9.3	
11 cm <sup>3</sup> /rev.	0.67 cu.in/rev.	11	

ROTATION (page 132)	CODES	B
Clockwise	D	
Anti-clockwise	S	

PORTS (page 141)	CODES	C
Flanged ports european standard	P	
Flanged ports german standard	B	
Threaded ports GAS (BSPP)	G	
Threaded ports SAE (ODT)	R	

DRIVE SHAFTS (page 142)	CODES	D
European Tapered 1:8	18	
European Tapered 1:8	19	
SAE A splined 9T	51	
SAE AA parallel Ø12,7	80	
SAE parallel Ø12,7	83	

H	VALVES IN THE COVER (page 20)	CODE
	Fixed main relief valve	VS

G	SUCTION TYPES	CODE
	Common suction	UA*

F	SEALS	CODE
	Nitrile-butadiene rubber (nbr)	
	Viton	V

E	MOUNTING FLANGES (page 19)	CODES
	European standard	P0
	European standard	P01
	SAE AA (2 bolts)	S0
	SAE (4 bolts)	S1

\*UA: this type of multiple pump is a Salami standard multiple pump which has only one inlet port opened, all the other inlet port are closed.  
In case of common suction, the code 1 - 2 or 3, correspond to the body where inlet is located.

**Order example:** 1.5PE 6.2 - 4.1D, ports GAS (G), drive shaft (19), mounting flange (P01).  
**1.5PE6.2/4.1D-G19P01**





---

**[www.salami.it](http://www.salami.it)**

You can find our most up to date "STANDARD SALES CONDITIONS" on our website.  
Potete trovare le nostre più aggiornate "CONDIZIONI DI VENDITA STANDARD" sul nostro sito.

Ph. +39 059 387 411 - [sales@salami.it](mailto:sales@salami.it)

---



Watch our tutorials on our official youtube channels:

Salami Fluid Power  
Salami Fluid Power World  
Salami Fluid Power France  
Salami Fluid Power España  
Salami Fluid Power Deutsch

---

**SALAMI S.P.A.**

Via Emilia Ovest 1006  
41123 Modena (Italy)  
Ph. +39 059 387 411  
F. +39 059 387 639  
sales@salami.it

**SALAMI ESPAÑA**

Poligono Industrial Armenteres  
C/Primer de Maig, 18, Nave 4  
08980 San Feliu de Llobregat  
Barcelona  
Ph. +34-93-6665451  
F. +34-93-6667826  
info@salamispain.com

**SALAMI FRANCE**

22, rue Louis Saillant  
69120 Valux en Velin  
Lyon  
Ph. +33-04-78809941  
F. +33-04-78803669  
e.pasian@salami.fr

**SALAMI HYDRAULICS N.A INC**

4630 Crossroads Park Drive  
Liverpool  
NY 13088 - USA  
Ph. +1-315-295-2363  
F. +1-315-295-2364  
info@salamihydraulics.com

hydratop.it