2.5PB

Aluminium gear pumps

Technical Catalogue

E0.138.0219.02.00IM05



salami 

hydrotop.ir

GEAR PUMPS

SALAMI gear pumps are available with displacements from 1.4 cm³/rev to 99 cm³/rev (*from 0.09 cu.in/rev to 6.03 cu.in/rev*).

Multiple pumps can always be realized combining stages taken from different or same series.

Several options of shafts, flanges and ports as for European, German and American standards are available for all the pumps.

SALAMI gear pumps offer:

- High volumetric efficiency thanks to an innovative design and an accurate control of machining tolerances.
- Axial compensation achieved by the use of floating bushes that allow high volumetric efficiency throughout the working pressure range.
- DU bearings to ensure high pressure capability.
- 12 teeth integral gear and shaft.
- Aluminium body.
- Cast iron flange and cover.
- Double shaft seals.
- Nitrile seals as standard and Viton seals in high temperature applications.
- All pumps are hydraulically tested after assembly to ensure the highest standard performance.
- Gear pumps are ideal for mobile equipment including: snow plows, light duty equipment, farm vehicles, town trucks, cherry pickers, lift gates, utility vehicles, aerial devices, hoists, spreaders, fan drive.
- Also available Bidirectional rotation.

WORKING CONDITIONS

- Pump inlet pressure (absolute pressure)	0.8 to 1.5 bar (11.6 to 21.7 psi)
- Minimum operating fluid viscosity	12 mm ² / sec
- Max starting viscosity	800 mm ² / sec
- Suggested fluid viscosity range	17 - 65 mm ² / sec
- Fluid operating temperature range	-20 to 80 °C
- Fluid operating temperature range with FPM seals (Viton)	-15 to 110°C
- Fluid operating temperature range with HNBR seals*	-30 to 110°C
- Hydraulic fluid	Mineral oil according to DIN 51524. Other hydraulic fluids on request.

*Available on request.

DEFINITION OF PRESSURES

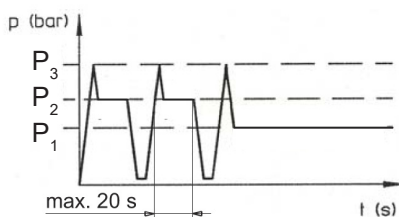

P_3 = Peak pressure

P_2 = Intermittent operating pressure (1/3 of working time)

P_1 = Continuous operating pressure

EO.100.0821.02.001M03



DRIVE SHAFTS

Radial and axial loads on the shafts must be avoided since they reduce the life of the unit. In order to avoid misalignment during the assembly with the primary engine, a connection with “Oldham” coupling (or coupling having convex toothed hub) is recommended.

ROTATION

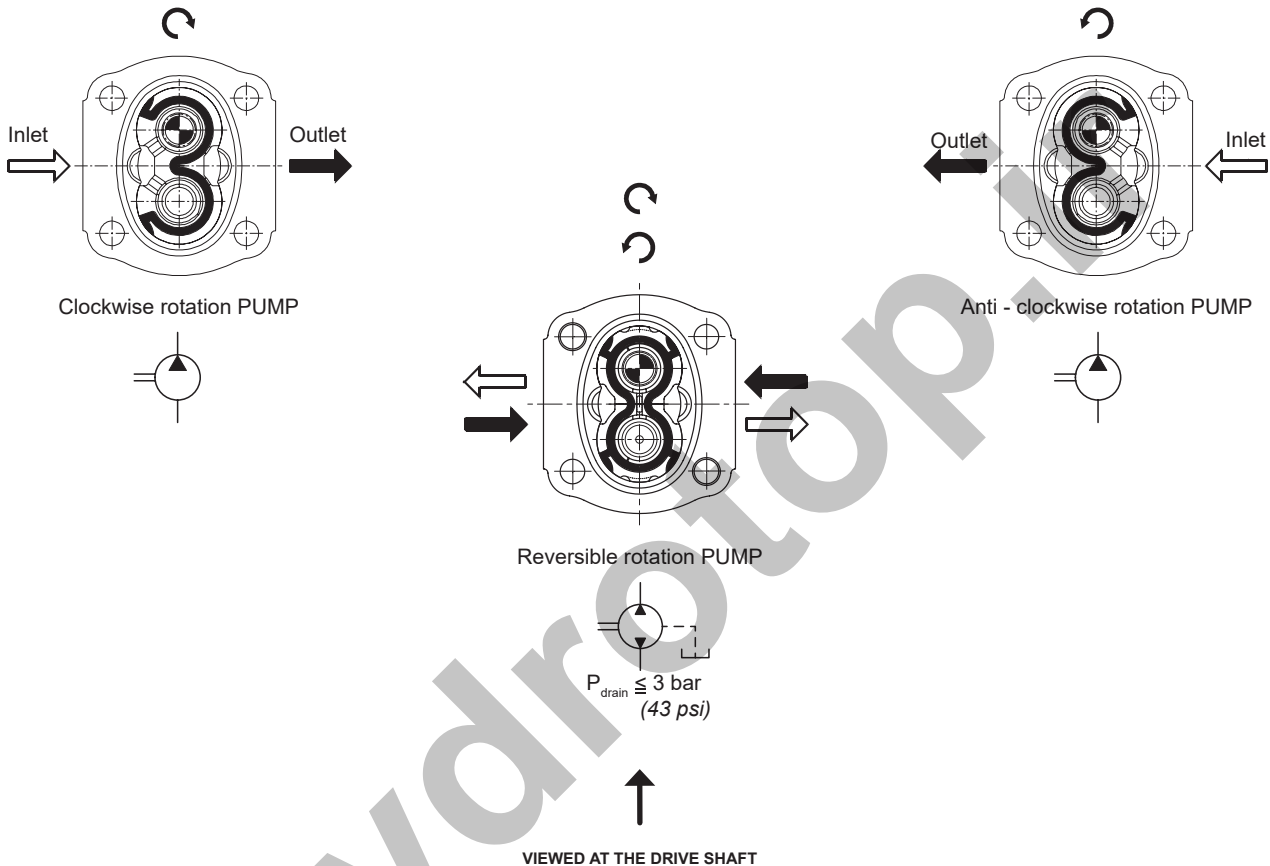

HYDRAULIC PIPE LINE

To ensure favorable suction conditions it is important to keep pressure drop in suction pipe line to a minimum value (see TECHNICAL DATA). To calculate hydraulic pipe line size, the designer can use; as an approximate guide, the following fluid speed figures:

From 1 to 2 m/sec on suction pipe line
From 6 to 10 m/sec on pressure pipe line

From 3.28 to 6.36 ft/sec on suction pipe line
From 19.7 to 32.8 ft/sec on pressure pipe line

The lowest fluid speed values in pipe lines is recommended when the operating temperature range is high and/or for continuous duty.

The highest value is recommended when the temperature difference is low and/or for intermittent duty.

When tandem pumps are supplied by 2 different reservoirs with 2 different fluids it is necessary to specify “AS” version.

FILTRATION INDEX RECOMMENDED

Working pressure	>200 bar/2900 psi	<200 bar/2900 psi
Contamination class NAS 1638	9	10
Contamination class ISO 4406	19/18/15	20/19/16
Achieved with filter $\beta_x=75$	15 μm	25 μm

COMMON FORMULAS FOR PUMPS

$$C = \text{Input torque} = \frac{q \cdot \Delta p}{62.8 \cdot \eta_m} \text{ (Nm)}$$

$$P = \text{Input power} = \frac{q \cdot n \cdot \Delta p \cdot 10^{-3}}{600 \eta_m} \text{ (kW)}$$

$$Q = \text{Outlet flow} = \frac{q \cdot n \cdot \eta_v}{1000} \text{ (l/min)}$$

LEGENDA

Δp = Working pressure (bar)

q = Displacement (cm^3/rev)

n = Speed (min^{-1})

η_m = Mechanical eff. (0.92)

η_v = Volumetric eff. (0.95)

IDENTIFICATION LABEL

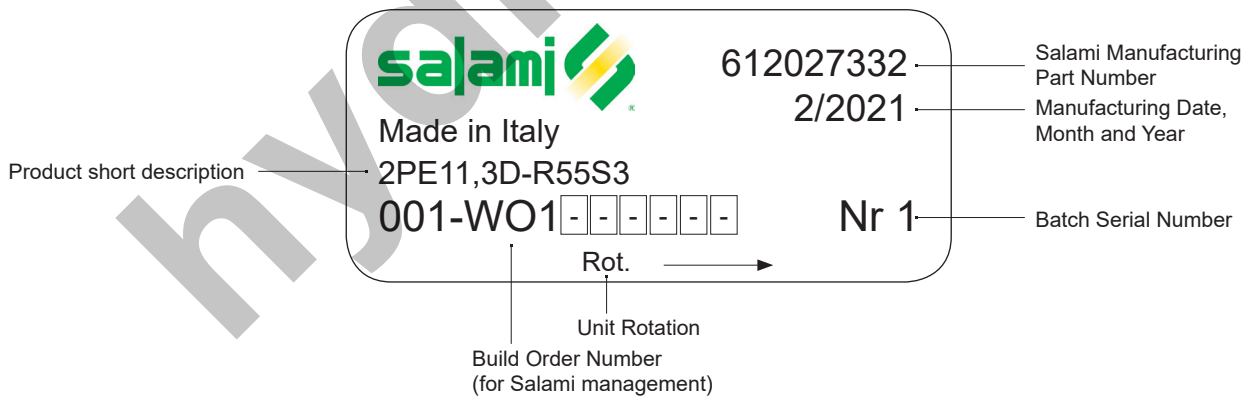

EO.100.0821.02.001M03

TECHNICAL DATA

GROUP 1.5 - E SERIES	Displacement		Continuous pressure P ¹		Intermittent pressure P ²		Peak pressure P ³		Max. speed	Min. speed
	cm ³ /rev	cu.in/rev	bar	psi	bar	psi	bar	psi	rpm	
1.5PE - 1.4	1.4	0.09	250	3625	270	3915	290	4205	5000	700
1.5PE - 2.1	2.1	0.13	250	3625	270	3915	290	4205	5000	700
1.5PE - 2.8	2.8	0.17	250	3625	270	3915	290	4205	4500	700
1.5PE - 3.5	3.5	0.21	250	3625	270	3915	290	4205	4500	700
1.5PE - 4.1	4.1	0.25	250	3625	270	3915	290	4205	4000	700
1.5PE - 5.2	5.2	0.32	230	3335	250	3625	270	3915	4000	700
1.5PE - 6.2	6.2	0.38	230	3335	250	3625	270	3915	3600	600
1.5PE - 7.6	7.6	0.46	200	2900	220	3190	250	3625	3300	600
1.5PE - 9.3	9.3	0.57	180	2610	200	2900	240	3480	3000	600
1.5PE - 11	11	0.67	170	2465	190	2755	220	3190	3000	600

GROUP 2 - E SERIES	cm ³ /rev	cu.in/rev	bar	psi	bar	psi	bar	psi	rpm	
2PE - 3.2*	3.2	0.19	250	3625	280	4060	300	4350	4000	600
2PE - 3.9*	3.9	0.24	250	3625	280	4060	300	4350	4000	600
2PE - 4.5	4.6	0.27	250	3625	280	4060	300	4350	4000	600
2PE - 6.5	6.5	0.4	250	3625	280	4060	300	4350	4000	600
2PE - 8.3	8.2	0.5	250	3625	280	4060	300	4350	3500	500
2PE - 10.5	10.6	0.65	250	3625	280	4060	300	4350	3500	500
2PE - 11.3	11.5	0.68	250	3625	280	4060	300	4350	3500	500
2PE - 12.5	12.7	0.77	250	3625	280	4060	300	4350	3500	500
2PE - 13.8	13.8	0.84	250	3625	280	4060	300	4350	3500	500
2PE - 16	16.6	1.01	250	3625	280	4060	300	4350	3000	400
2PE - 19	19.4	1.15	220	3190	240	3480	260	3750	3000	400
2PE - 22.5	22.9	1.37	200	2900	220	3190	240	3480	2750	400
2PE - 26	26.6	1.62	180	2610	200	2900	220	3190	2500	400

*Available only as rear pump

GROUP 2.5 - B SERIES	cm ³ /rev	cu.in/rev	bar	psi	bar	psi	bar	psi	rpm	
2.5PB - 5.5*	5.97	0.36	250	3625	280	4060	300	4350	3000	600
2.5PB - 8.3*	8.29	0.50	250	3625	280	4060	300	4350	3000	600
2.5PB - 11.5*	11.76	0.72	250	3625	280	4060	300	4350	3000	600
2.5PB - 13.8*	14.07	0.86	250	3625	280	4060	300	4350	3000	600
2.5PB - 16	16	0.97	250	3625	280	4060	300	4350	3000	600
2.5PB - 19	19.3	1.17	250	3625	280	4060	300	4350	3000	600
2.5PB - 22	22.2	1.35	250	3625	280	4060	300	4350	3000	500
2.5PB - 25	25.2	1.53	250	3625	280	4060	300	4350	3000	500
2.5PB - 28	27.6	1.68	250	3625	280	4060	300	4350	3000	500
2.5PB - 32	32.4	1.97	230	3335	250	3625	260	3750	3000	500
2.5PB - 38	38.1	2.32	200	2900	220	3190	240	3480	2750	400
2.5PB - 44	44.2	2.69	170	2465	190	2755	210	3040	2500	400

*Available only as rear pump. Displacements 11.5-13.8 are available as single pump only with drive shaft "55".



TECHNICAL DATA

	Displacement		Continuous pressure P ¹		Intermittent pressure P ²		Peak pressure P ³		Max. speed	Min. speed
	cm ³ /rev	cu.in/rev	bar	psi	bar	psi	bar	psi		
GROUP 3 - E SERIES									rpm	
3PE - 21	20.6	1.26	250	3625	280	4060	300	4350	3000	600
3PE - 27	27	1.65	250	3625	280	4060	300	4350	3000	600
3PE - 33	33.5	2.04	250	3625	280	4060	300	4350	3000	600
3PE - 38	38.7	2.36	250	3625	280	4060	300	4350	2750	500
3PE - 46	46.9	2.86	250	3625	270	3915	280	4060	2750	500
3PE - 55	54.1	3.3	220	3190	240	3480	250	3625	2500	400
3PE - 65	63.1	3.85	200	2900	220	3190	240	3480	2500	400
3PE - 75	73.4	4.48	180	2610	200	2900	220	3190	2500	400

	Displacement		Continuous pressure P ¹		Intermittent pressure P ²		Peak pressure P ³		Max. speed	Min. speed
	cm ³ /rev	cu.in/rev	bar	psi	bar	psi	bar	psi		
GROUP 3.5 - C SERIES									rpm	
3.5PC - 55	54.8	3.34	250	3625	280	4060	300	4350	2750	400
3.5PC - 64	63.2	3.85	250	3625	280	4060	300	4350	2750	350
3.5PC - 75	74.7	4.55	230	3335	250	3625	280	4060	2500	300
3.5PC - 87	88	5.36	210	3040	230	3330	260	3750	2250	300
3.5PC - 98*	99	6.03	200	2900	220	3190	250	3625	2000	300

*Displacement 98 are special release, please contact sales department.

- ⚠ *Max Speed must be lowered by 10% for system working continuously at p¹ pressure.
Max pressure must be lowered by 10% for bi-directional pump.*

ROTATION CHANGING INSTRUCTIONS FOR UNITS

Keep the working surface cleaned as well as the exterior of the pump before starting and avoid inner contamination of the pump. The pump shown below is a clockwise rotating pump. To achieve anti-clockwise rotation, please read the following instructions carefully.

CLOCKWISE ROTATION

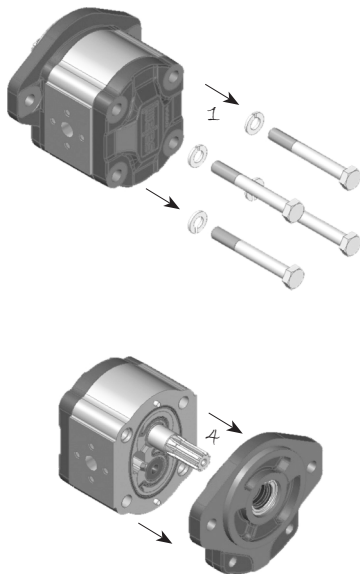

1 - Loosen and fully unscrew the bolts.

2 - Lay the pump on the working area in order to have the mounting flange turned upside.

3 - Coat the shaft end with grease to avoid damaging the shaft seal.

4 - Remove the flange and lay it on the working area; verify that the seal is correctly located in the body seat.

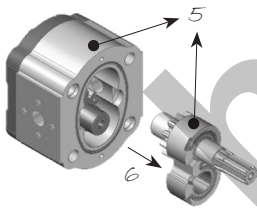

5 - Mark the position of the bushing and eventually of the thrust plate, as well, with reference to the body.

6 - Remove the bushing, thrust plate and the driving gear taking care to avoid driven gear axial shifts.

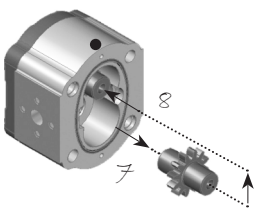

7 - Draw out the driven gear from its housing, taking care to avoid rear cover axial shifts.

8 - Re-locate the driven gear in the position previously occupied by the driving gear.

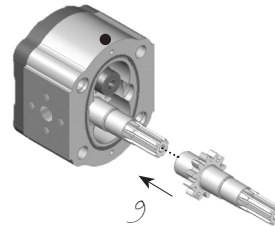

9 - Re-locate the driving gear in the position previously occupied by the driven gear.

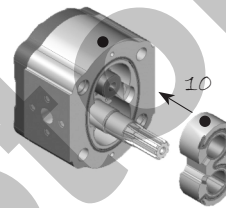

10 - Replace the bushing and thrust plate taking care that:

- marks are located as on the picture
- surface containing the seal is visible
- seal and its protection are correctly located.

11 - Clean the body and mounting flange facing surfaces.

12 - Verify that the two plugs are located in the body.

13 - Refit the mounting flange, turned 180° from its original position.

14 - Replace the bolts and tighten clockwise evenly to an appropriate torque.

15 - Check that the shaft rotates freely.

16 - Mark on the flange the new direction of rotation.

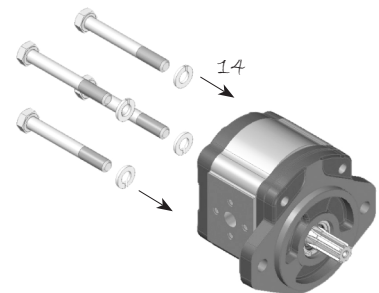

ANTI - CLOCKWISE ROTATION



INDEX

Shafts And Flanges Combination	67
Assembling Dimensions And Working Conditions.....	68
Flanged And Threaded Ports.....	69
Drive Shafts.....	70
Mounting Flanges	71
Outrigger Bearing	72
Rear Covers	74
Pressure Compensated Control And Priority Flow Valve	76
Load Sensing Priority Valve.....	77
Multiple Gear Pumps Assembling Dimensions.....	78
2.5PB Combination With Pump 2PE	79
Performance Curves.....	80
How To Order Single Pumps	84
How To Order Multiple Pumps.....	85

Final revised edition - February 2019





The data in this catalogue refers to the standard product.

The policy of Salami S.p.A. consists of a continuous improvement of its products. It reserves the right to change the specifications of the different products whenever necessary and without giving prior information.

If any doubts, please contact our sales department.

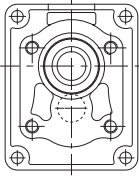
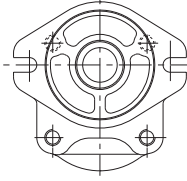
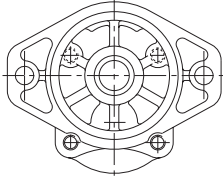
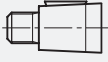
hydrotop.ir

SHAFTS AND FLANGES COMBINATION

2.5PB			
	CODE P2 European standard	CODE S2 SAE A 2 Bolts	CODE S3 SAE B 2 Bolts
 CODE 38 - Tapered 1:8	38P2		
 CODE 53 - SAE A splined 10T		53S2	
 CODE 54 - SAE A splined 11T		54S2	
 CODE 55 - SAE B splined 13T		55S2	55S3
 CODE 87 - SAE B parallel		87S2	87S3

Note: other versions available, see shafts and flanges information.

Displacements up to 2.69 cu.in./rev
Pressure up to 4350 psi



GEAR PUMPS

Displacements up to 44.2 cm³/rev
Pressure up to 300 bar

ASSEMBLING DIMENSIONS AND WORKING CONDITIONS

Type		5.5*	8.3*	11.5*	13.8*	16	19	22	25	28	32	38	44
Displacement	cm ³ /rev	5.97	8.29	11.76	14.07	16	19.3	22.2	25.2	27.6	32.4	38.1	44.2
	cu.in./rev	0.36	0.50	0.72	0.86	0.97	1.17	1.35	1.53	1.68	1.97	2.32	2.69
Dimension A	mm	52.2	54.6	58.2	60.6	63	66.5	70	72.5	85	90.5	96.5	103
	in	2.05	2.15	2.29	2.38	2.45	2.59	2.73	2.82	3.31	3.52	3.76	4.06
Dimension C	mm	26.1	27.3	29.1	30.3	31.5	33.25	35	36.25	42.5	45.25	48.25	51.5
	in	1.02	1.07	1.14	1.19	1.20	1.29	1.36	1.41	1.65	1.76	1.88	2.03
Continuous pressure	P ¹ bar	250	250	250	250	250	250	250	250	250	230	200	170
	psi	3625	3625	3625	3625	3625	3625	3625	3625	3625	3335	2900	2465
Intermittent pressure	P ² bar	280	280	280	280	280	280	280	280	280	250	220	190
	psi	4060	4060	4060	4060	4060	4060	4060	4060	4060	3625	3190	2755
Peak pressure	P ³ bar	300	300	300	300	300	300	300	300	300	260	240	210
	psi	4350	4350	4350	4350	4350	4350	4350	4350	4350	3750	3480	3040
Max speed	rpm	3000	3000	3000	3000	3000	3000	3000	3000	3000	3000	2750	2500
Min speed	rpm	600	600	600	600	600	600	500	500	500	500	400	400
Weight	kg	3.40	3.60	3.80	4.10	3.40	3.60	3.80	4.10	4.50	4.75	5.00	5.30
	lbs	7.48	7.92	8.36	9.02	7.48	7.92	8.36	9.02	9.92	10.47	11.00	11.66

*Available only as rear pump, displacements 11.5-13.8 are available as single pump only with drive shaft "55".

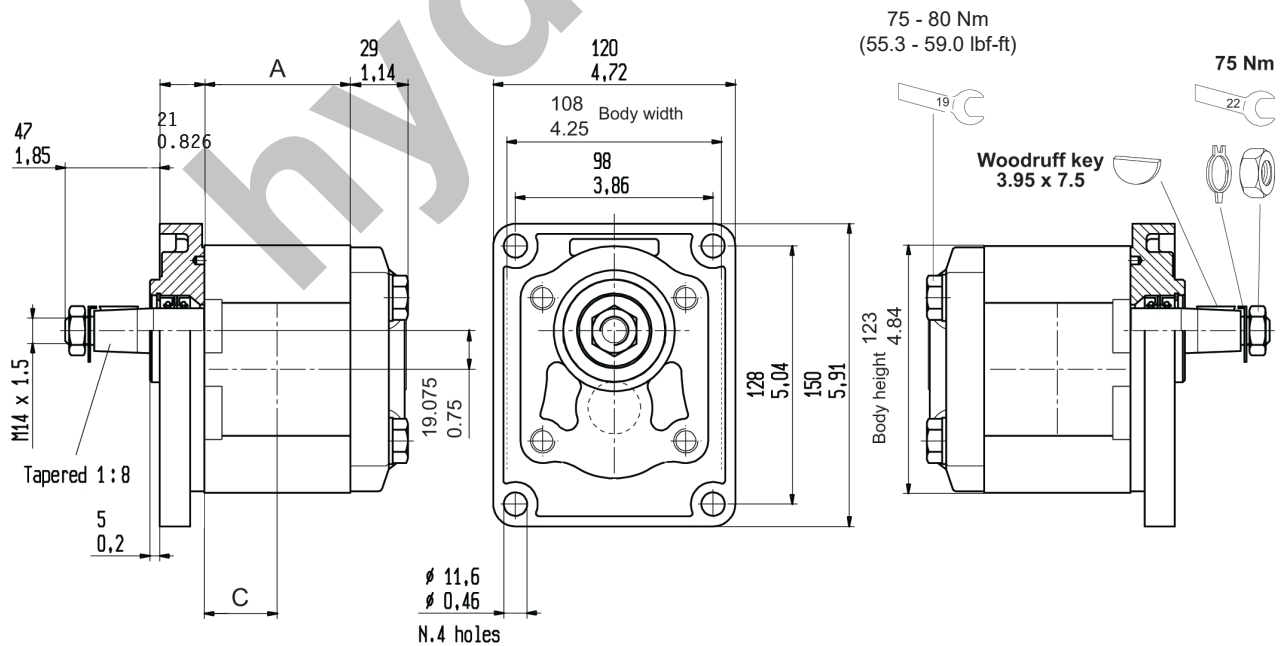

E0.138.0219.02.00IM05

FLANGED AND THREADED PORTS

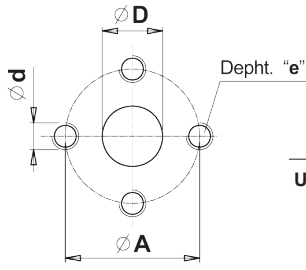

code P

Flanged ports
european standard



TYPE	INLET				OUTLET			
	Ø D	Ø A	d	e	Ø D	Ø A	d	e
From 5.5 to 8.3	13 (0.51")	30 (1.18")	M6	13 (0.51")	13 (0.51")	30 (1.18")	M6	13 (0.51")
From 11.5 to 19	20 (0.79")	40 (1.57")	M8					
From 22 to 44	25 (0.97")	51 (2.01")	M10	16 (0.62")	18 (0.70")	40 (1.56")	M8	18 (0.70")

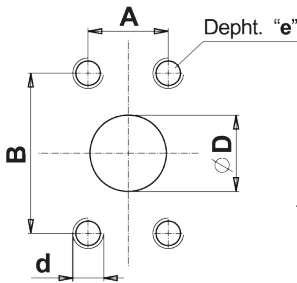

code S

Flanged ports
SAE J518
AMERICAN STANDARD
THREAD



BI-DIRECTIONAL PUMPS Special version available on request.



TYPE	INLET					OUTLET				
	Ø D	B	A	d	e	Ø D	B	A	d	e
From 16 to 44	25 (0.97")	52.4 (2.06")	26.2 (1.02")	3/8 16 unc	16 (0.62")	18 (0.70")	47.6 (1.87")	22.2 (0.86")	3/8 16 unc	16 (0.62")



BI-DIRECTIONAL PUMPS Special version available on request.

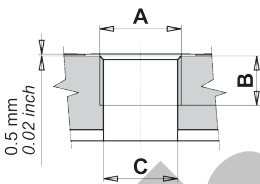

code G

Threaded ports
GAS (BSPP)



TYPE	INLET			OUTLET		
	A	B	ØC	A	B	ØC
From 5.5 to 22	G3/4	16 (0.62")	20 (0.78")	G1/2	15 (0.59")	
From 25 to 44	G1	19 (0.74")	23 (0.91")	G3/4	16 (0.62")	20 (0.78")



BI-DIRECTIONAL PUMPS Special version available on request.

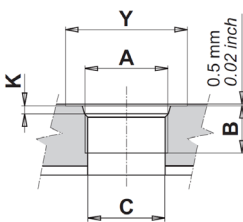

code R

Threaded ports
SAE (ODT)



TYPE	INLET					OUTLET				
	A	B	ØC	Y	K	A	B	ØC	Y	K
From 5.5 to 22	1-1/16-12 UN (SAE 12)	19 (0.74")	20 (0.78")	41 (1.61")	3.3 (0.12")	7/8-14 UNF (SAE 10)	14 (0.54")	15 (0.59")	34 (1.32")	2.5 (0.10")
From 25 to 44	1-5/16-12 UN (SAE 16)		23 (0.91")	49 (1.93")		1-1/16-12 UN (SAE 12)	19 (0.74")	20 (0.78")	41 (1.61")	3.3 (0.12")



BI-DIRECTIONAL PUMPS Special version available on request.

EO.138.0219.02.001M05



DRIVE SHAFTS

Woodruff Key (3.95x7.5)

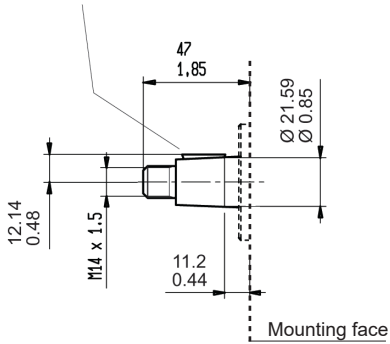

code 38 Max torque 250 Nm (2213 lbf in)
Tapered 1:8

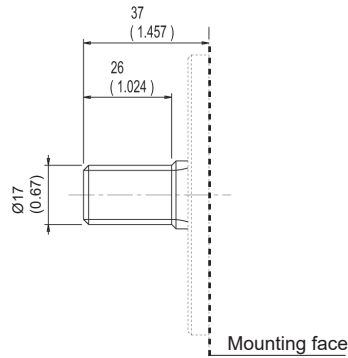

code 53 Max torque 125 Nm (1106 lbf in)
**SAE A Splined 10T-16/32DP Ansi B92
1a 1976**

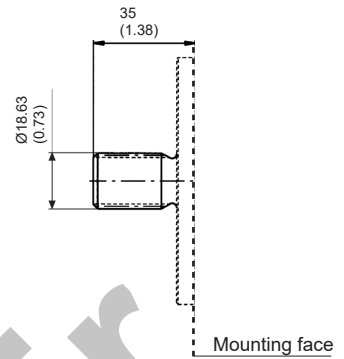

code 54 Max torque 150 Nm (1327 lbf in)
**SAE A Splined 11T-16/32DP Ansi B92
1a 1976**

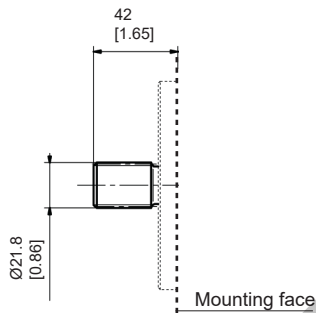

code 55 Max torque 320 Nm (2832 lbf in)
**SAE B Splined 13T-16/32DP Ansi B92
1a 1976**

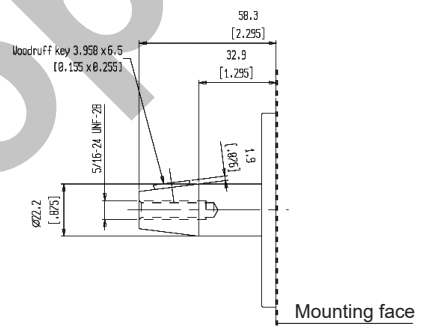

code 37 Max torque 200 Nm (1770 lbf in)
Tapered 1:4

Woodruff Key (6.35x6.35x17.7)

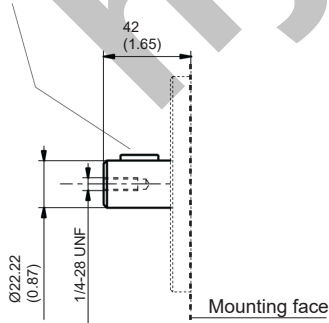

code 87 Max torque 220 Nm (1950 lbf in)
SAE B Parallel

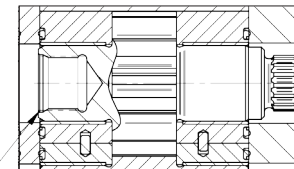

INTERNAL SPLINED

code 64 Max torque 115 Nm (1017.8 lbf in)
**DIN 5480 internal splined
(only for rear pumps)**

E0.138.0219.02.00IM05

MOUNTING FLANGES

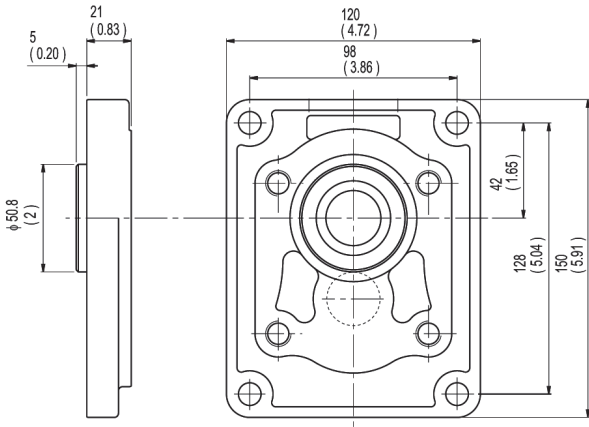

P2 European standard
With shaft code 38

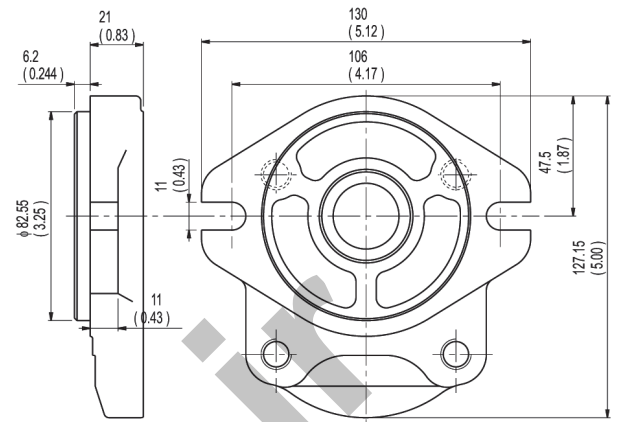

S2 SAE A 2 bolts
With shaft code 53-54-55-87

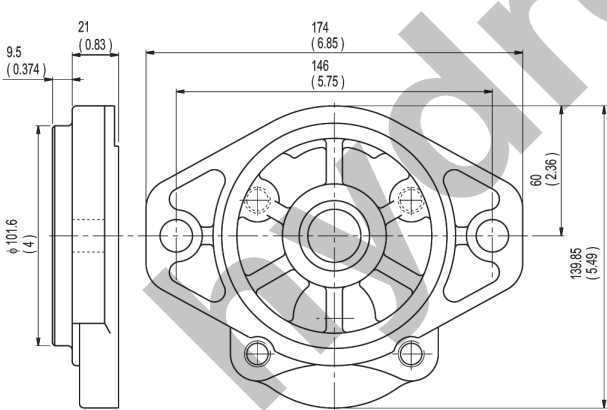

S3 SAE B 2 bolts
With shaft code 55-87

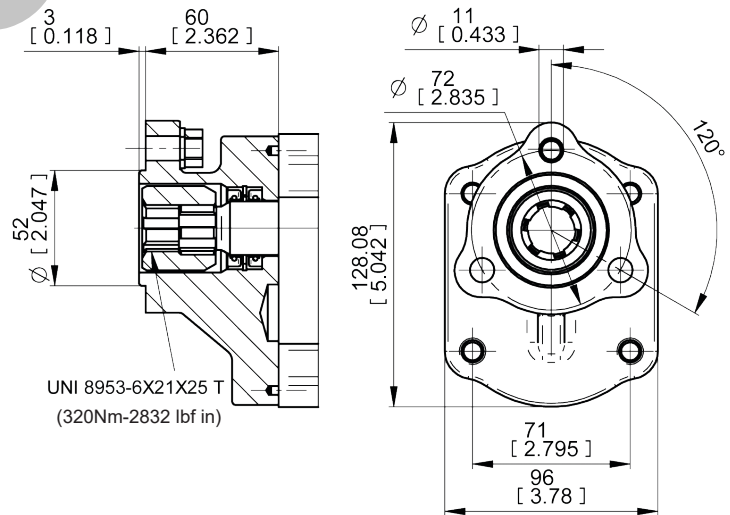

T1 3 BOLT UNI 8953
With shaft code 73

EO.138.0219.02.001M05

OUTRIGGER BEARING

The following diagrams show radial load capability of the bearing.

Calculation according to ISO 281 at 10 cSt.

TYPE	H
16	63 (2.45")
19	66.5 (2.59")
22	70 (2.73")
25	72.5 (2.82")
28	85 (3.31")
32	90.5 (3.52")
38	96.5 (3.76")
44	103 (4.06")

L=Distance between mounting flange and radial force point of application.

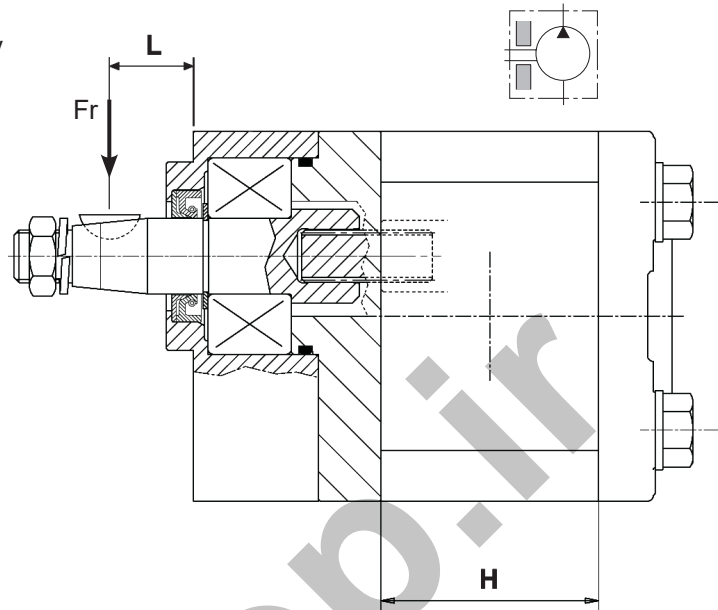

Example:
Fr = 2500 N
L = 12.5
Speed = 1000 rpm

Expected life: 700 hrs

For Code CP

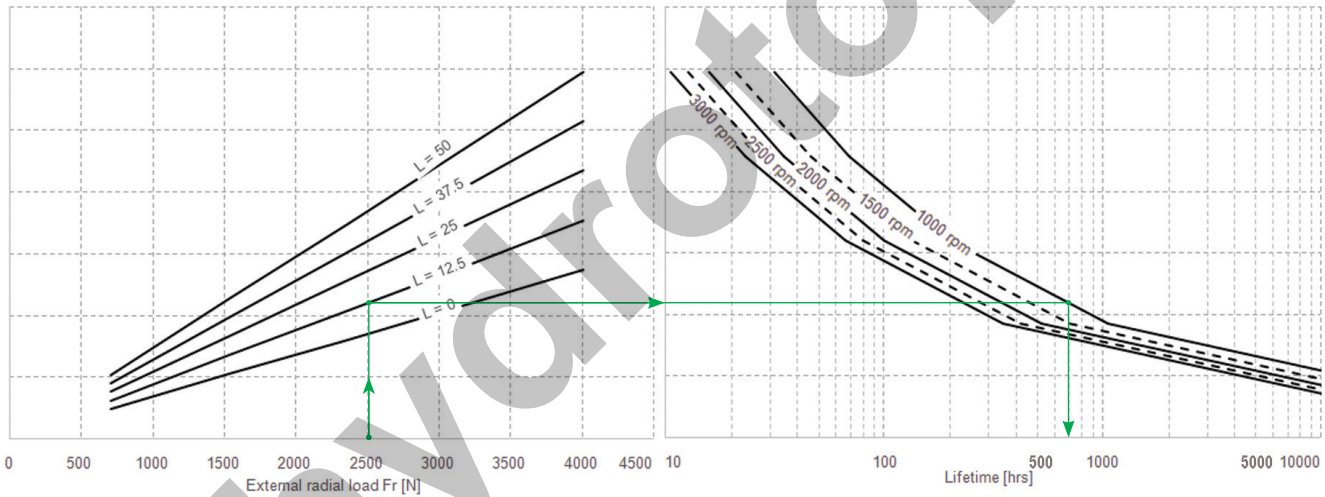

For Code Z1

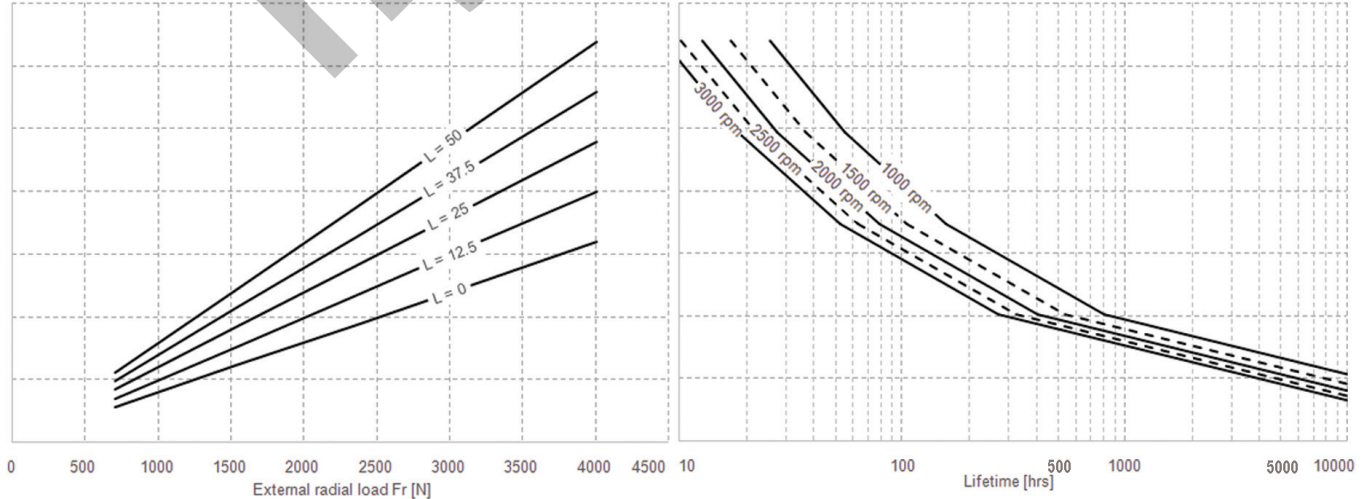

E0.138.0219.02.00IM05



MOUNTING FLANGES WITH BEARING

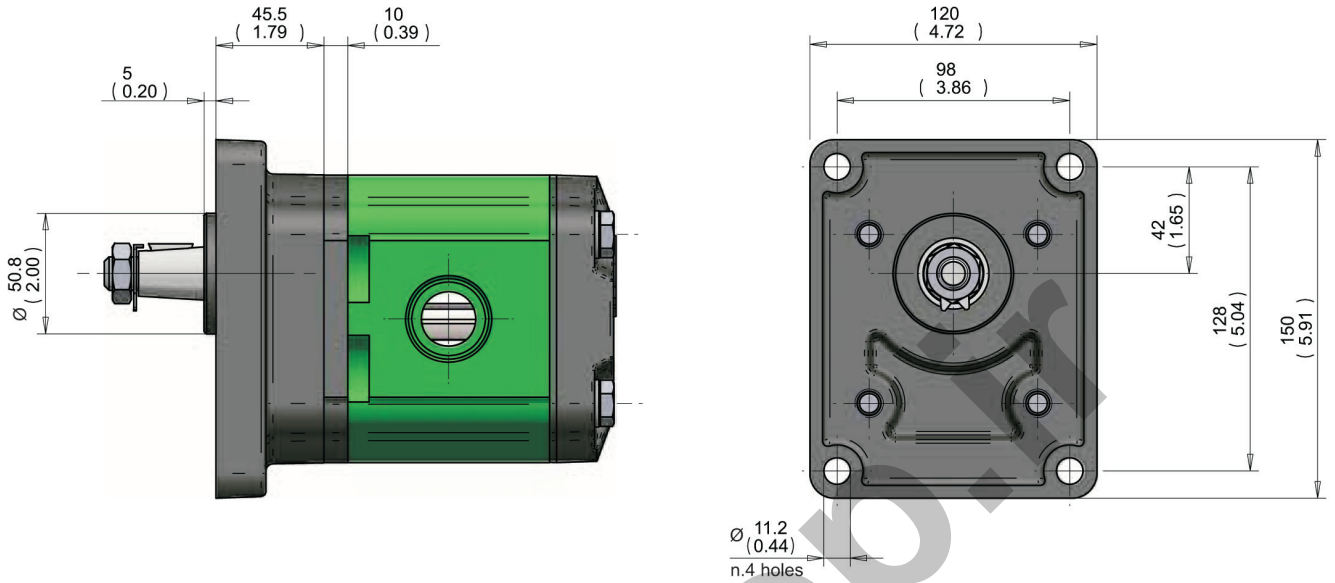

CP European standard mounting flange
With shaft code 38 (see page 70)

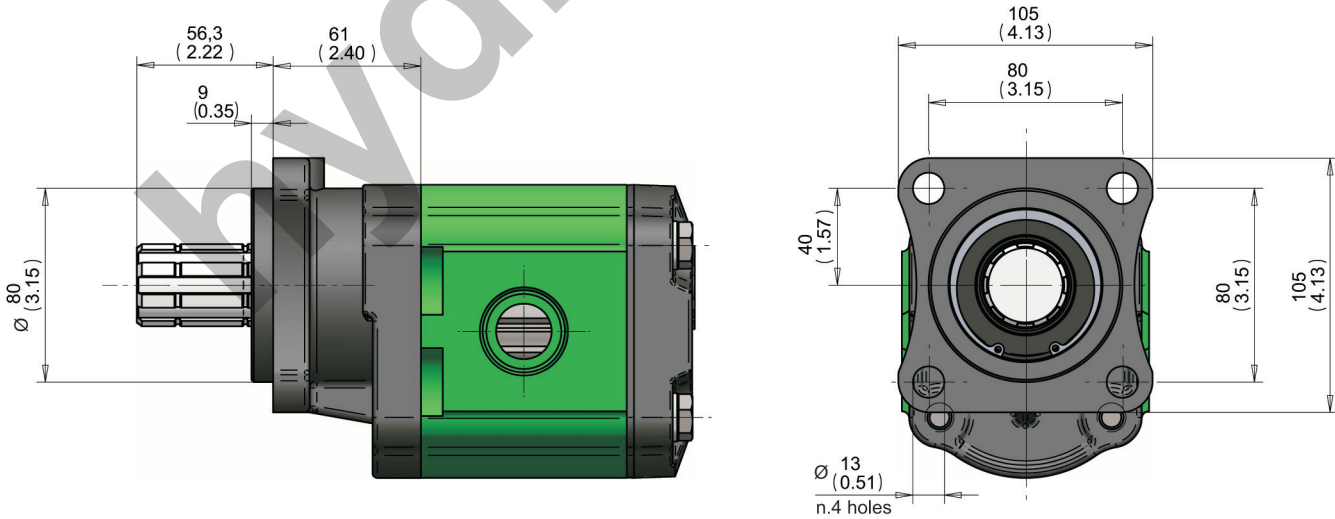

Z1 4 Bolts (ZF gear box) ISO 7653
With shaft code 66

EO.138.0219.02.001M05



REAR COVERS

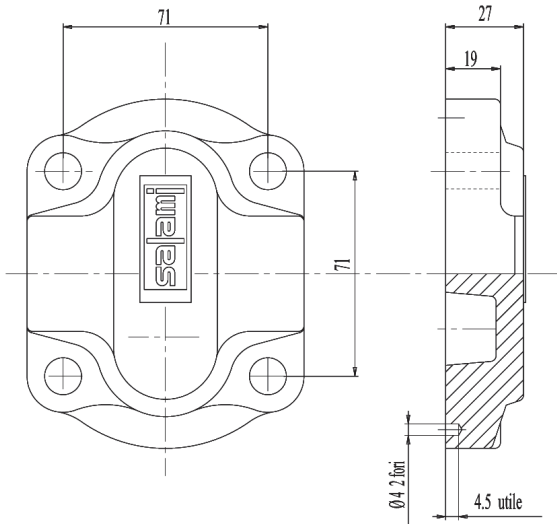

Standard rear cover for unidirectional pumps

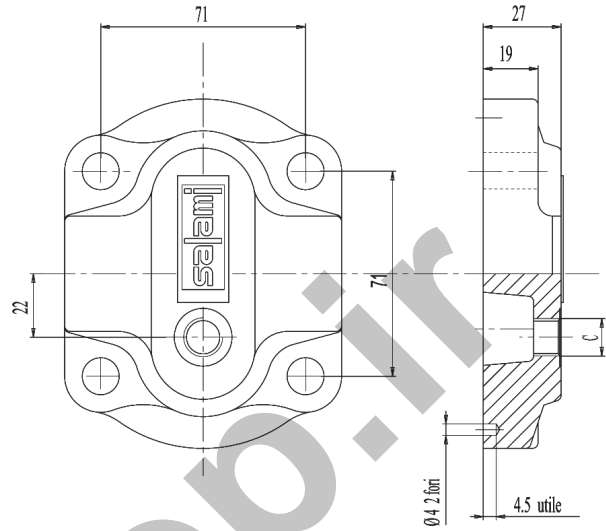

Standard rear cover for reversible pumps, with external drain C.

C
9/16-18 UNF-2B (SAE6)
G3/8

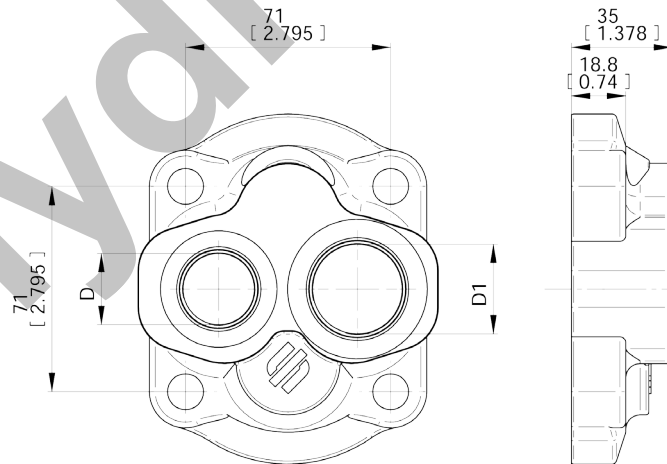

UNIDIRECTIONAL PUMPS

code 1

D	D1
1-1/16-12 UN-2B (SAE12)	1-5/16-12 UN-2B (SAE16)
G3/4	G1

On request outlet port only.

E0.138.0219.02.00IM05



REAR COVERS WITH RELIEF VALVE

code VS

With main relief valve
with internal unloading line.
Rear cover with fixed setting main relief valve.

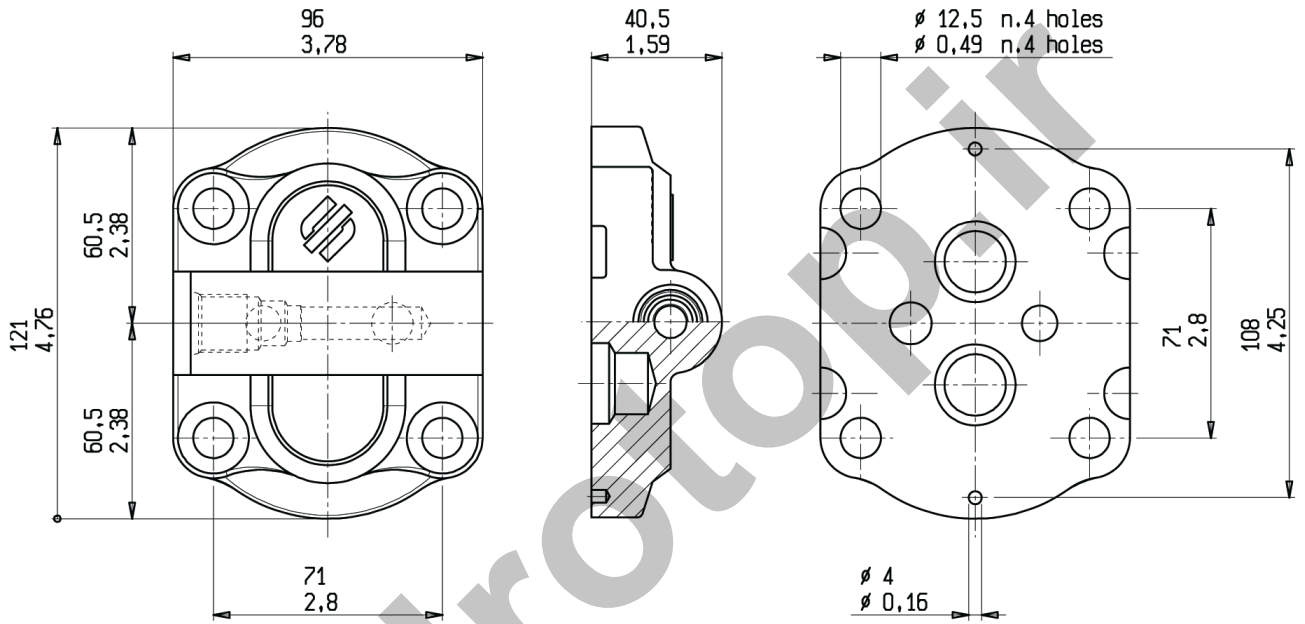
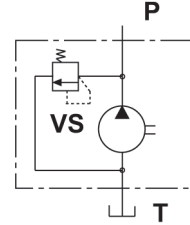

Available values of fixed setting

bar	psi	bar	psi
25	362	160	2320
32	464	175	2538
40	580	190	2756
50	725	210	3046
63	914	230	3336
80	1160	250	3626
100	1450	280	4061
125	1813	315	4569
140	2030	350	5076

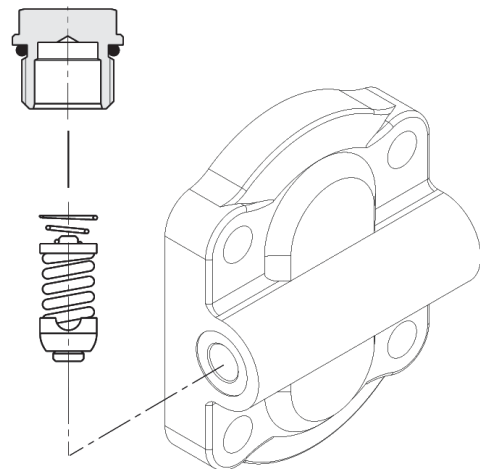

EO.138.0219.02.001M05

PRESSURE COMPENSATED CONTROL AND PRIORITY FLOW VALVE

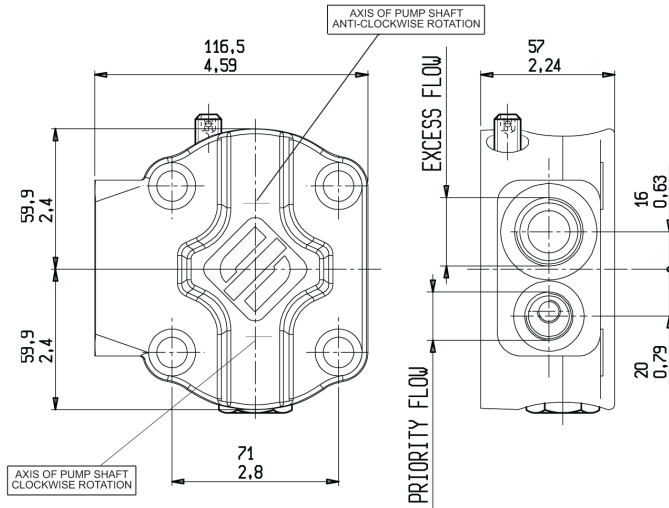

VP1 - VPS1
SIDE PORTS

Priority flow ports	Excess flow ports
G 3/8	G 3/4
(SAE8)	(SAE12)
3/4 - 16 UNF - 2B	1-1/16 - 12 UNF - 2B

CALIBRATED ORIFICE Φ d (mm/inch)	FLOW RATE (l/min - gpm) ± 10%
1.5 / (0.06")	2.5 - (0.66)
2 / (0.08")	4 - (1.06)
2.4 / (0.09")	6 - (1.59)
2.8 / (0.11")	8 - (2.11)
3.1 / (0.12")	10 - (2.64)
3.5 / (0.14")	12.5 - (3.30)
4 / (0.16")	16 - (4.23)
4.4 / (0.17")	20 - (5.28)
4.9 / (0.19")	25 - (6.61)

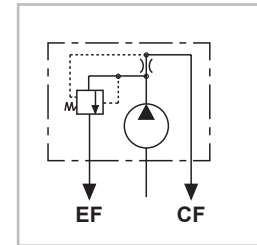

code VP1

Priority flow valve, excess flow to second actuator.

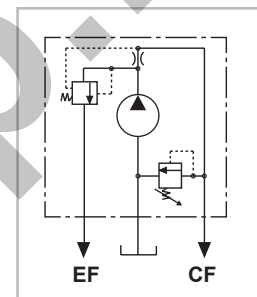

code VPS1

Priority flow valve, excess flow to second actuator with pressure relief valve on priority flow line.

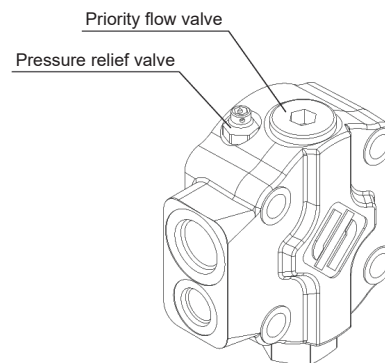

PRIORITY FLOW VALVE (VP - VPS)

3 Ways flow control priority valve. It ensures a constant flow to CF port, given by the screwed control orifice (see table) and regardless of the pump speed; the excess flow is available for other functions at the EF port.

The two lines CF and EF can be loaded simultaneously and the max pressure of the priority line can be limited by a relief valve connected to the suction port.

LOAD SENSING PRIORITY VALVE

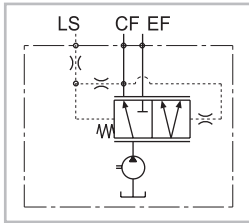

code VPD1

Load sensing priority valve with dynamic signal without main relief valve.

CF = Priority flow port
EF = Excess flow port
LS = Load sensing signal port

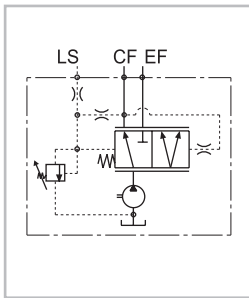

code VPDS1

Load sensing priority valve with dynamic signal with main relief valve.

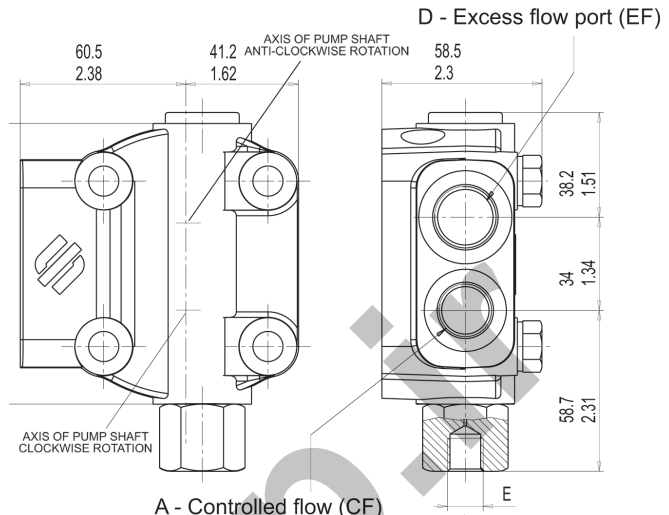

VPD1 - VPDS1
SIDE PORTS

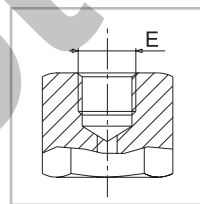

Female fitting

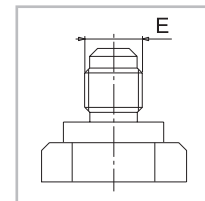

Male fitting

Minimum load sensing signal (LS) = 4 bar (28 psi)

A	D	E
G 3/8	G 3/4	G 1/4
(SAE8)	(SAE12)	(SAE4)
3/4 - 16 UNF - 2B	1-1/16 - 12 UN - 2B	7/16 - 20 UNF - 2B

LOAD SENSING PRIORITY VALVES (VDP1-VDPS1)

The load sensing priority valve is a control valve able to divide the flow generated by the pump, coming from the port P, in two different flows named Qcf and Qef.

The Qcf flow follows the user request, the flow Qef changes according to the equation:

$$Q_{in} = Q_{cf} + Q_{ef}$$

This valve is used in hydraulic steering systems, the CF port is connected to the inlet of power steering unit while the other functions (lifter etc...) are connected to the EF port. The load sensing LS signal of the valve is connected to the LS of powersteering unit.

The regulated flow Qcf depends on the steering speed, the remaining flow Qef is available for the other functions and complies with the equation

$$Q_{ef} = Q_{in} - Q_{cf}$$

MULTIPLE GEAR PUMPS ASSEMBLING DIMENSIONS

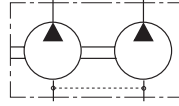
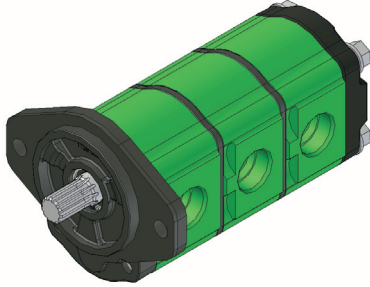

MULTIPLE GEAR PUMPS with inlet port on each body

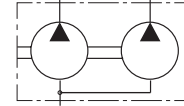

MULTIPLE GEAR PUMPS with common inlet port*

*In case of common inlet port, to avoid too high value of oil speed, 40 l/min is the max. sucked flow for the downstream pump. Commercial code UA.

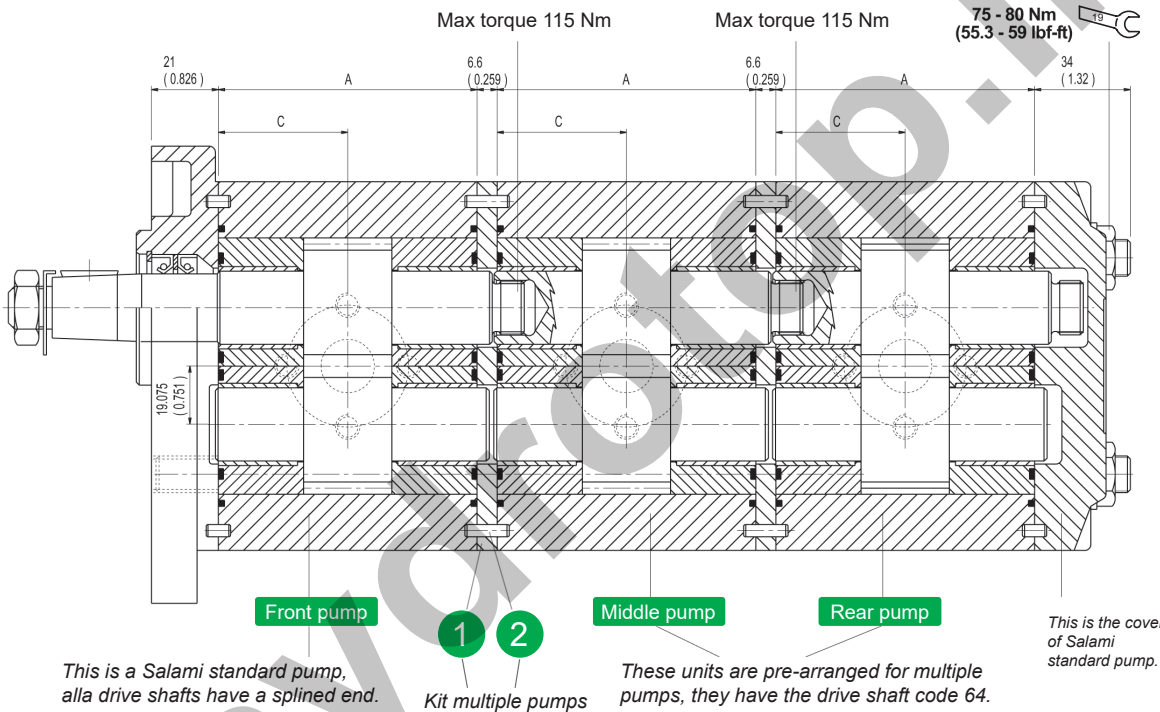

The 2.5PB pumps can be easily transformed into front pump in the multiple units. All drive shafts are pre-arranged and have a splined end according to DIN 5482. The first unit must always be the same size or bigger than following units. The features and performances are the same of the corresponding single units: only in the case of simultaneous operating you have to verify that the inlet torque is lower than the max. transmissible by the drive shaft. Finally to assemble the multiple pump you need to order bolts of the right length.

Type		5.5	8.3	11.5	13.8	16	19	22	25	28	32	38	44
Dimension A	mm	52.2	54.6	58.2	60.6	63	66.5	70	72.5	85	90.5	96.5	103
	in	2.05	2.15	2.29	2.38	2.48	2.62	2.76	2.85	3.35	3.56	3.80	4.06
Dimension C	mm	26.1	27.3	29.1	30.3	31.5	33.25	35	36.25	42.5	45.25	48.25	51.5
	in	1.03	1.07	1.14	1.19	1.22	1.29	1.36	1.41	1.65	1.76	1.88	2.03

E0.138.0219.02.00IM05



2.5PB COMBINATION WITH PUMP 2PE

PD2

Kit multiple pumps
Pre-arranged for 2PE rear

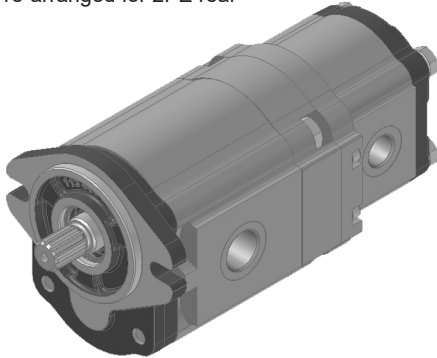

ALL THE PUMPS
CAN BE ALSO
MULTIPLE

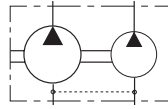

**MULTIPLE
GEAR PUMPS
with inlet port
on each body**

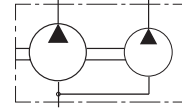

**MULTIPLE
GEAR PUMPS
with common
inlet port***

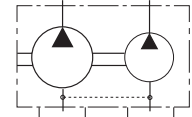

**MULTIPLE
GEAR PUMPS
with separated
stages**

*In case of common inlet port, to avoid too high value of oil speed, 30 l/min is the max. sucked flow for the downstream pump. Commercial code **UA**.

code AS

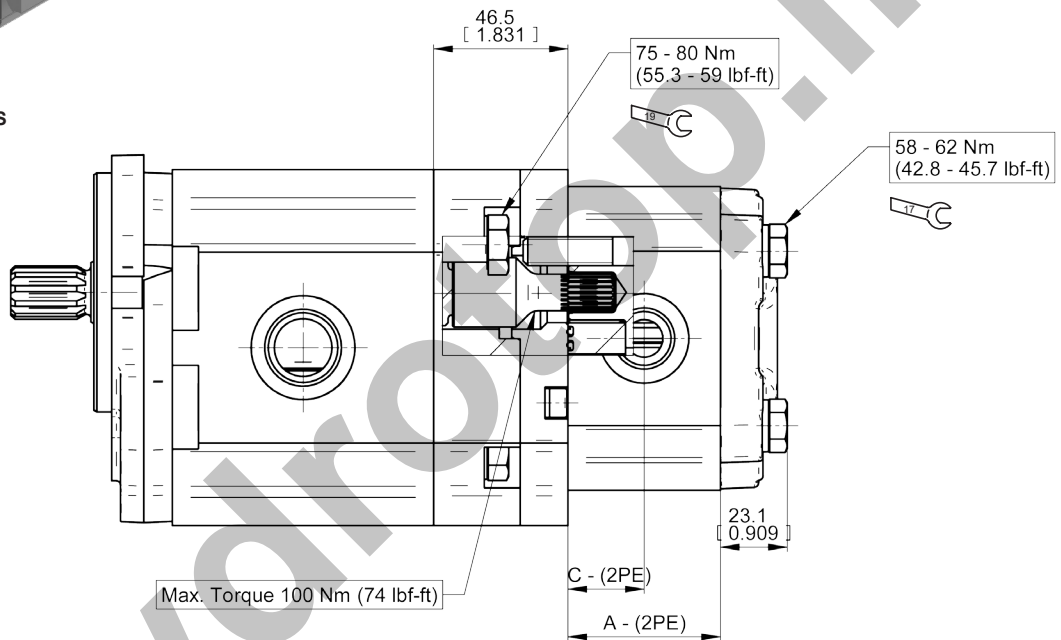

2PE-Type		3.2*	3.9*	4.5	6.5	8.3	10.5	11.3	12.5	13.8	16	19	22.5	26
Dimension A - 2PE	mm		47.1		49.95	52.8	56.3	59.7	63.5	67.5	75.6	81	86.8	
	in		1.83		1.97	2.07	2.22	2.35	2.5	2.65	2.97	3.19	3.42	
Dimension C - 2PE	mm		23.55		25	26.4	28.15	29.75	31.75	33.75	37.80	40.5	43.4	
	in		0.93		0.98	1.04	1.11	1.17	1.25	1.33	1.49	1.59	1.71	

*Available only as rear pump

EO.138.0219.02.001M05



PERFORMANCE CURVES

Performance curves carried out with oil viscosity at 21 cSt and oil temperature at 50°C

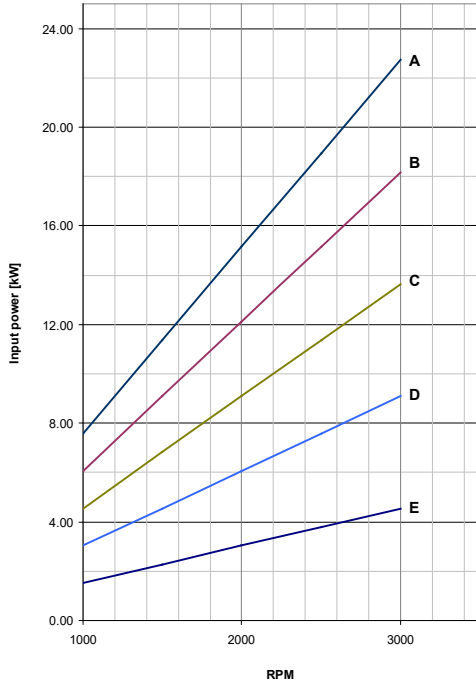

2.5PB - 16

A=250bar - (3625 psi)
B=200bar - (2900 psi)
C=150bar - (2175 psi)
D=100bar - (1450 psi)
E=50bar - (725 psi)

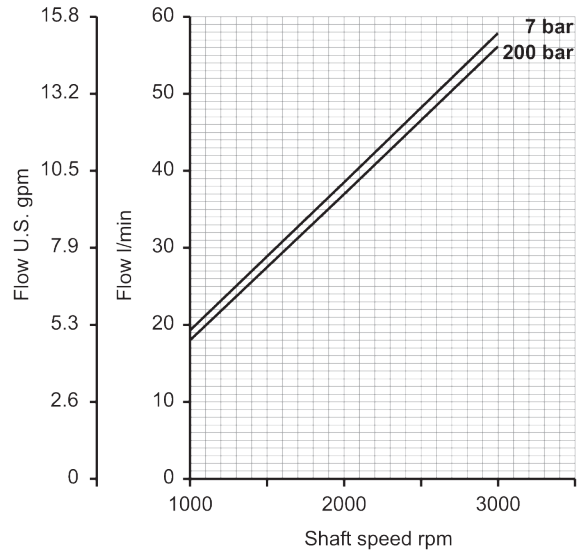
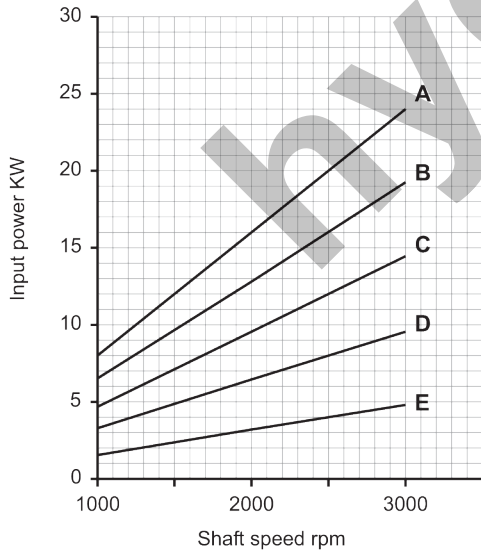

2.5PB - 19

E0.138.0219.02.00IM05



PERFORMANCE CURVES

Performance curves carried out with oil viscosity at 21 cSt and oil temperature at 50°C

A=250bar - (3625 psi)
B=200bar - (2900 psi)
C=150bar - (2175 psi)
D=100bar - (1450 psi)
E=50bar - (725 psi)

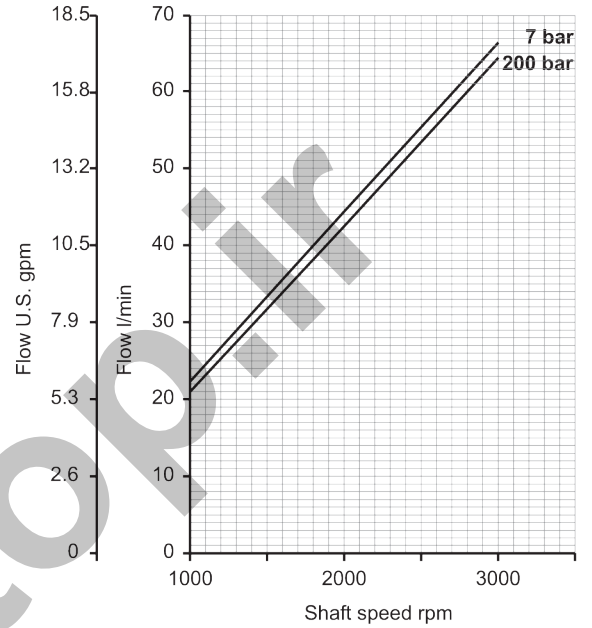
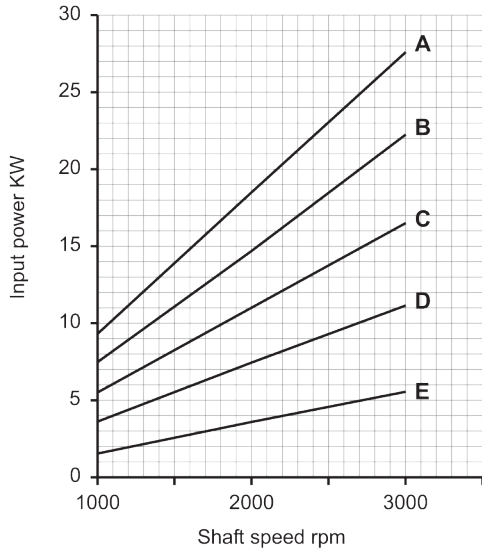

2.5PB - 22

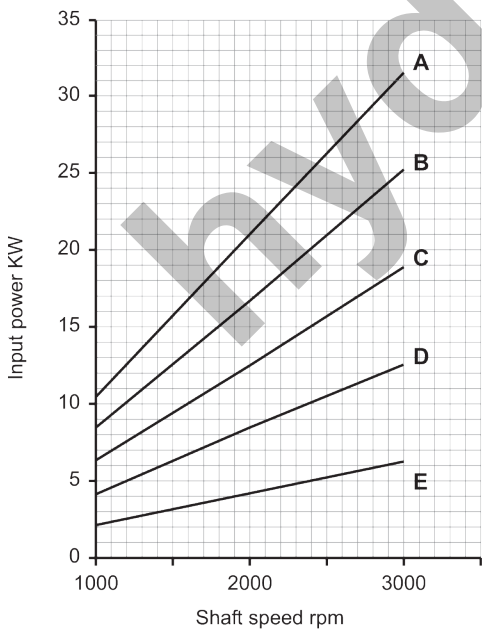

A=250bar - (3625 psi)
B=200bar - (2900 psi)
C=150bar - (2175 psi)
D=100bar - (1450 psi)
E=50bar - (725 psi)

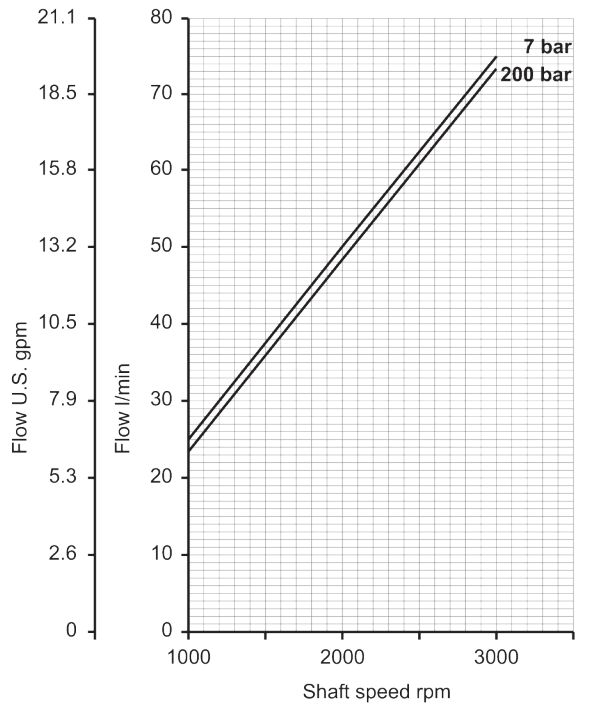

2.5PB - 25

EO.138.0219.02.001M05



PERFORMANCE CURVES

Performance curves carried out with oil viscosity at 21 cSt and oil temperature at 50°C

A=250bar - (3625 psi)
 B=200bar - (2900 psi)
 C=150bar - (2175 psi)
 D=100bar - (1450 psi)
 E=50bar - (725 psi)

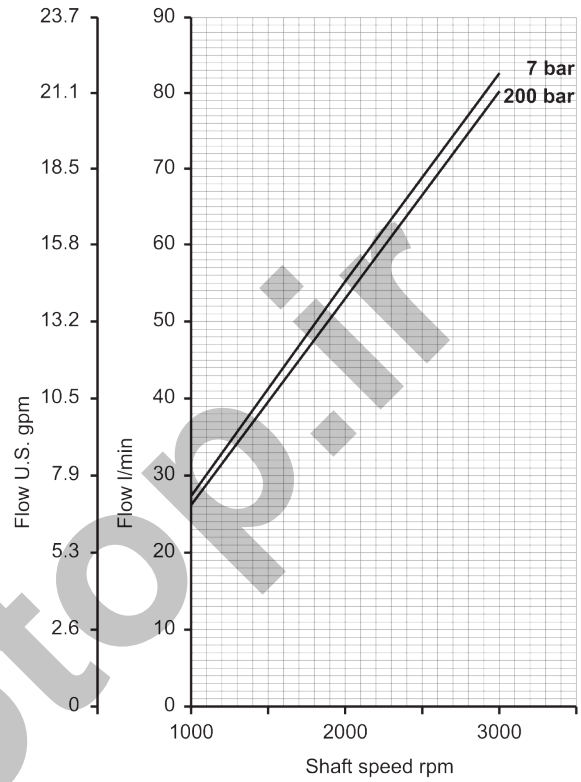
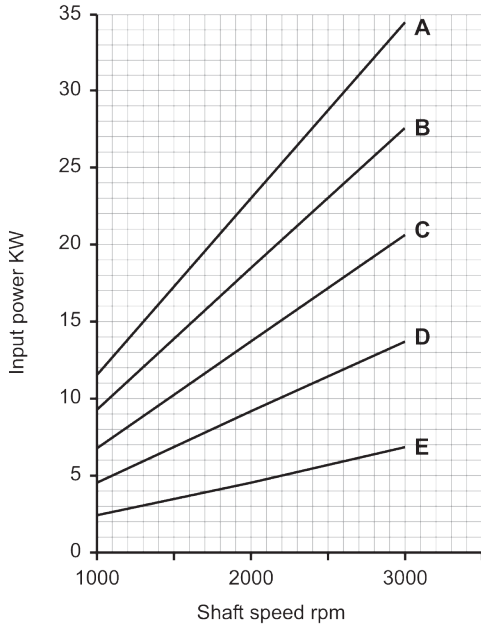

2.5PB - 28

A=230bar - (3345 psi)
 B=200bar - (2900 psi)
 C=150bar - (2175 psi)
 D=100bar - (1450 psi)
 E=50bar - (725 psi)

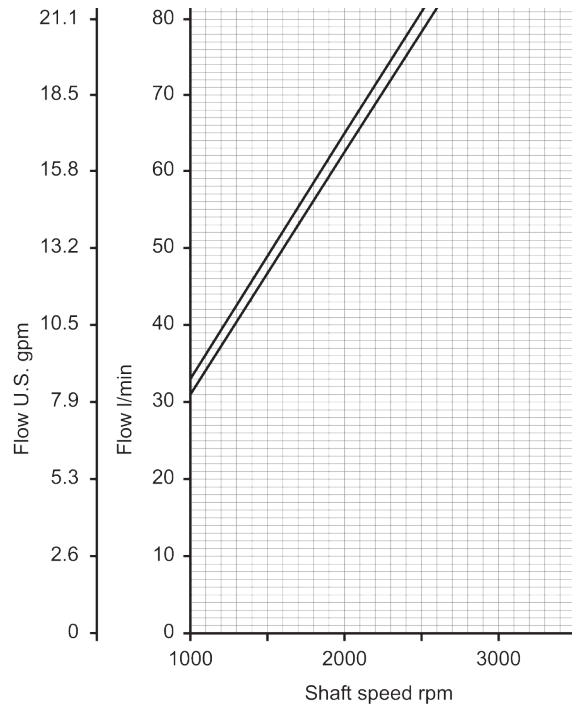
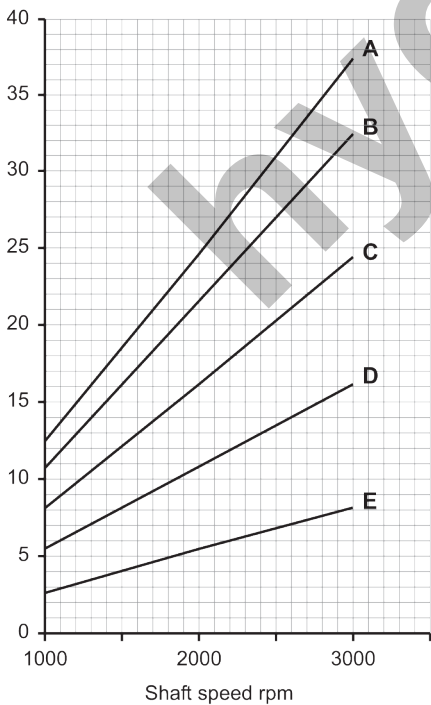

2.5PB - 32



PERFORMANCE CURVES

Performance curves carried out with oil viscosity at 21 cSt and oil temperature at 50°C

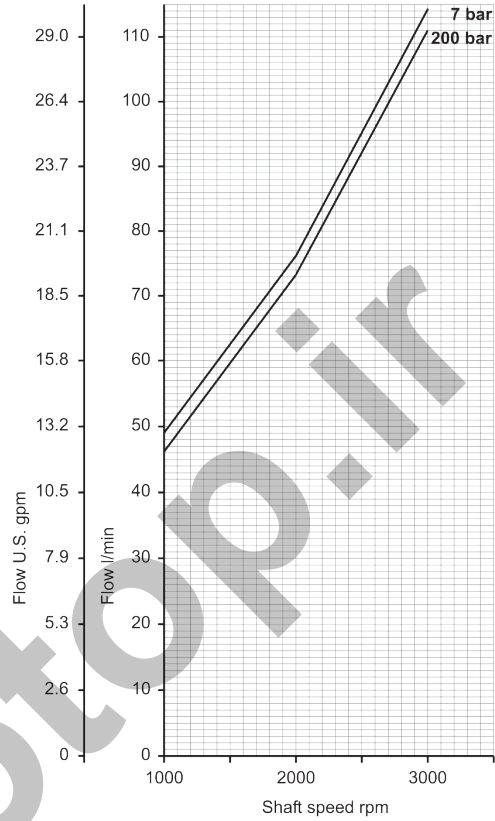
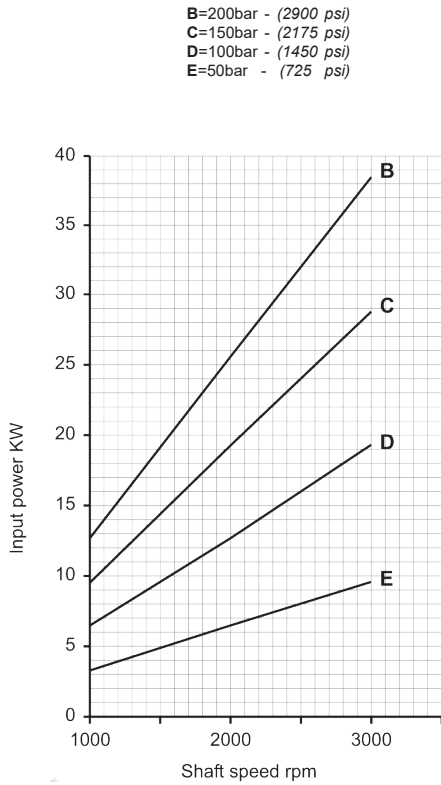

2.5PB - 38

B=200bar - (2900 psi)
C=150bar - (2175 psi)
D=100bar - (1450 psi)
E=50bar - (725 psi)

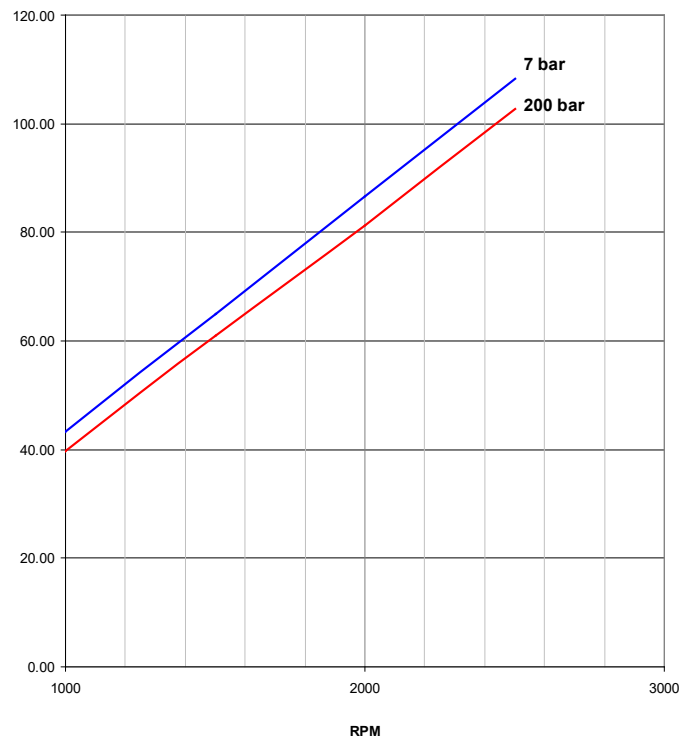
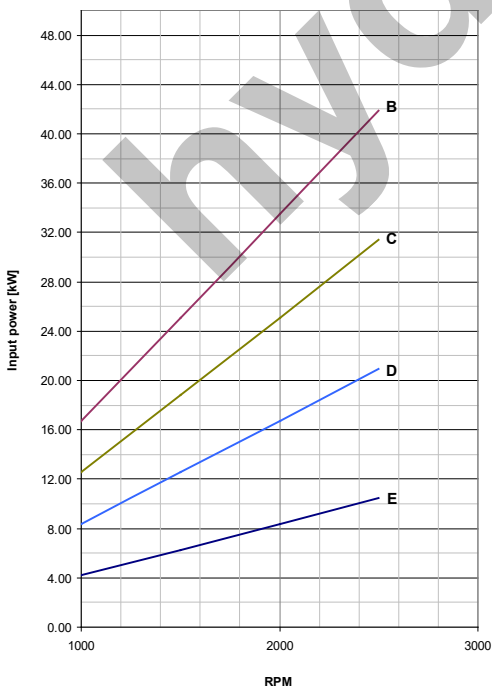

2.5PB - 44

EO.138.0219.02.001M05



SINGLE PUMPS

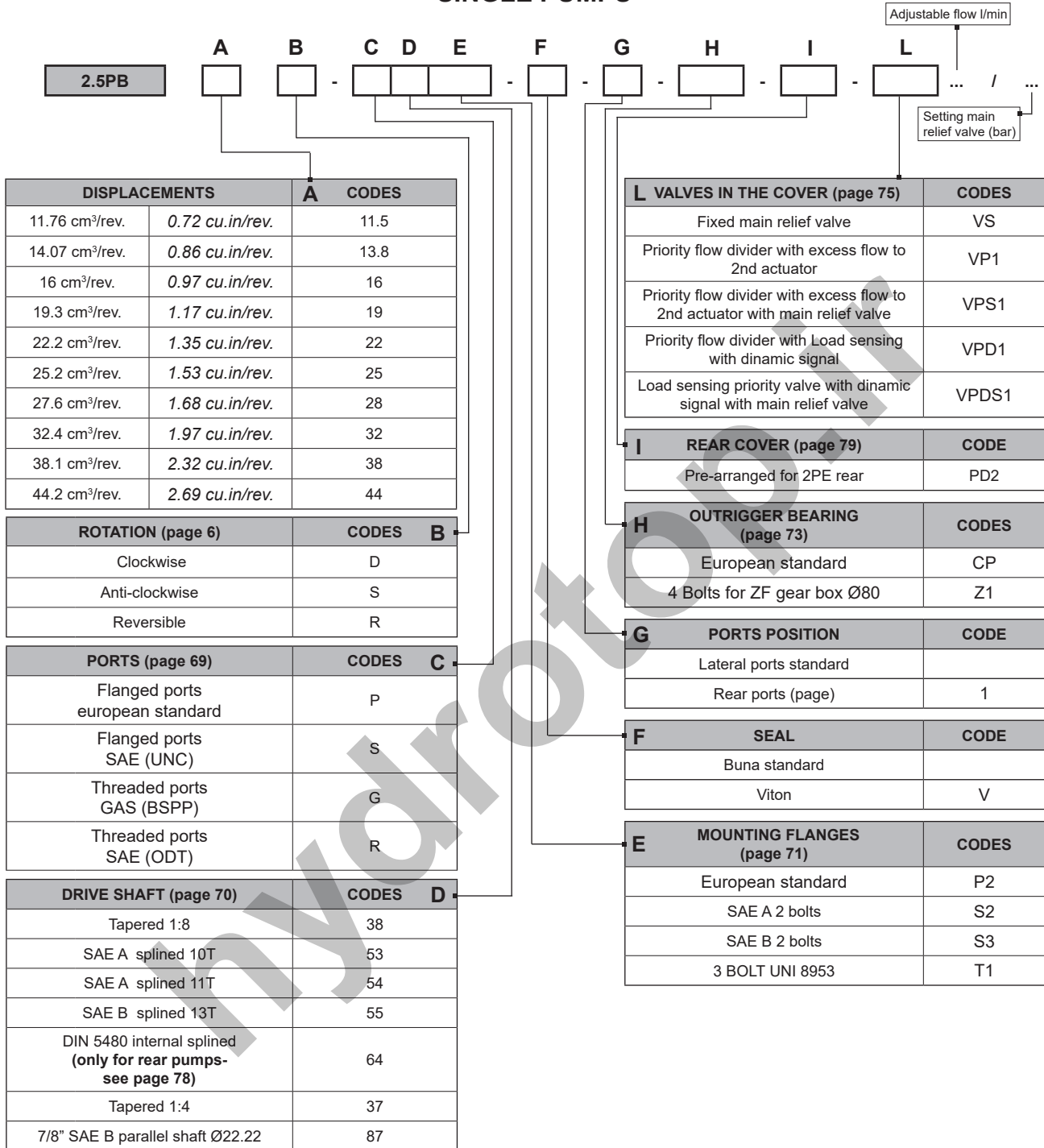

Order example: 2.5PB 19D, ports European standard (P), drive shaft (38), mounting flange (P2) with valve in the cover (VS 190 bar).
2.5PB19D-P38P2-VS190



MULTIPLE PUMPS



DISPLACEMENTS		A	CODES
5.97 cm ³ /rev.	0.36 cu.in/rev.		5.5
8.29 cm ³ /rev.	0.50 cu.in/rev.		8.3
11.76 cm ³ /rev.	0.72 cu.in/rev.		11.5
14.07 cm ³ /rev.	0.86 cu.in/rev.		13.8
16 cm ³ /rev.	0.97 cu.in/rev.		16
19.3 cm ³ /rev.	1.17 cu.in/rev.		19
22.2 cm ³ /rev.	1.35 cu.in/rev.		22
25.2 cm ³ /rev.	1.53 cu.in/rev.		25
27.6 cm ³ /rev.	1.68 cu.in/rev.		28
32.4 cm ³ /rev.	1.97 cu.in/rev.		32
38.1 cm ³ /rev.	2.32 cu.in/rev.		38
44.2 cm ³ /rev.	2.69 cu.in/rev.		44

ROTATION (page 6)	CODES	B
Clockwise		D
Anti-clockwise		S

PORTS (page 69)	CODES	C
Flanged ports european standard		P
Flanged ports SAE (UNC)		S
Threaded ports GAS (BSPP)		G
Threaded ports SAE (ODT)		R

DRIVE SHAFT (page 70)	CODES	D
Tapered 1:8		38
SAE A splined 10T		53
SAE A splined 11T		54
SAE B splined 13T		55
Tapered 1:4		37
7/8" SAE B parallel shaft Ø22.22		87

Order example: 2.5PB 32/28D, ports SAE (R), drive shaft (55), mounting flange (S3).
2.5PB32/28D-R55S3

M VALVES IN THE COVER (page 75)	CODES
Fixed main relief valve	VS
Priority flow divider with excess flow to 2nd actuator	VP1
Priority flow divider with excess flow to 2nd actuator with main relief valve	VPS1
Priority flow divider with Load sensing with dinamic signal	VPD1
Load sensing priority valve with dinamic signal with main relief valve	VPDS1

L REAR COVER (page 79)	CODE
Pre-arranged for 2PE rear	PD2

I OUTRIGGER BEARING (page 73)	CODES
European standard	CP
4 Bolts for ZF gear box Ø80	Z1

H PORTS POSITION	CODE
Lateral ports standard	
Rear ports (page)	1

G SUCTION PORTS	CODES
Common suction	UA*
Separated stages	AS

F SEAL	CODE
Buna standard	
Viton	V

E MOUNTING FLANGES (page 71)	CODES
European standard	P2
SAE A 2 bolts	S2
SAE B 2 bolts	S3
3 BOLT UNI 8953	T1

*UA: this type of multiple pump is a Salami standard multiple pump which has only one inlet port opened, all the other inlet port are closed.
In case of common suction, the code 1 - 2 or 3, correspond to the body where inlet is located.

EO.138.0219.02.001M05



hydrotop.ir

www.salami.it

You can find our most up to date "STANDARD SALES CONDITIONS" on our website.
Potete trovare le nostre più aggiornate "CONDIZIONI DI VENDITA STANDARD" sul nostro sito.

Ph. +39 059 387 411 - sales@salami.it



Watch our tutorials on our official youtube channels:

Salami Fluid Power
Salami Fluid Power World
Salami Fluid Power France
Salami Fluid Power España
Salami Fluid Power Deutsch

SALAMI S.P.A.

Via Emilia Ovest 1006
41123 Modena (Italy)
Ph. +39 059 387 411
F. +39 059 387 639
sales@salami.it

SALAMI ESPAÑA

Poligono Industrial Armenteres
C/Primer de Maig, 18, Nave 4
08980 San Feliu de Llobregat
Barcelona
Ph. +34-93-6665451
F. +34-93-6667826
info@salamispain.com

SALAMI FRANCE

22, rue Louis Saillant
69120 Valux en Velin
Lyon
Ph. +33-04-78809941
F. +33-04-78803669
e.pasian@salami.fr

SALAMI HYDRAULICS N.A INC

4630 Crossroads Park Drive
Liverpool
NY 13088 - USA
Ph. +1-315-295-2363
F. +1-315-295-2364
info@salamihydraulics.com

hydratop.it