

NEW

2XP
Aluminum Gear Pump



Xtreme



 **walvoil**
FLUID POWER | MOTION

A member of



2XP

Aluminum Gear Pump



Walvoil presents the new range of 2XP Pumps, with Aluminium body and Cast Iron flanges

These pumps are particularly suitable for all applications where traditional Aluminium pumps are used at the limit of their performance; eg. for installation on mobile equipment intended for heavy duty operating cycles, where pressures or mechanical stresses are typically higher.

Its new modular construction ensures an increased versatility maintaining the same configurations of 2SP Series allowing new options.

- High efficiencies
- Reduced number of components
- Reduced overall dimension
- Increased transmissible torque

NOTE: for motor configuration, please contact Sales Department.

GENERAL WORKING CONDITIONS

Displacement		from 4.1 to 31.5 cm ³ /rev from 0.25 to 1.92 in ³ /rev
Max continuous pressure	up to	250 bar - 3600 psi
Fluid		hydraulic mineral oil-based
Fluid temperature range	with NBR (buna N) seals	from -20 to +80 °C from -4 to +176 °F
	with FPM (viton) seals	from -15 to +100 °C from +5 to +212 °F
Viscosity	Recommended	from 15 to 92 mm ² /s (cSt)
	Permitted for starting	2000 mm ² /s (cSt)
Max level of contamination	Recommended for operating pressure > 150 bar (2150 psi)	20/18/15 ISO 4406 class 9 (NAS 1638)
	Recommended for operating pressure < 150 bar (2150 psi)	21/18/15 ISO 4406 class 10 (NAS 1638)

Technical data

GROUP 2XP	Displacement		Max continuous pressure		Max intermittent pressure		Max peak pressure		Max rotation speed rpm
	cm ³ /rev	in ³ /rev	bar	psi	bar	psi	bar	psi	
2XP 040	4.1	0.25	250	3600	270	3900	290	4200	4000
2XP 060	6.1	0.37	250	3600	270	3900	290	4200	4000
2XP 080	8.7	0.53	250	3600	270	3900	290	4200	3500
2XP 110	11.2	0.68	250	3600	270	3900	290	4200	3500
2XP 140	14.2	0.86	250	3600	270	3900	290	4200	3500
2XP 160	16.8	1.02	230	3350	240	3500	250	3600	3500
2XP 190	19.8	1.20	210	3050	220	3200	230	3350	3500
2XP 220	22.9	1.39	190	2750	200	2900	210	3050	3000
2XP 260	26.4	1.61	170	2450	180	2600	190	2750	3000
2XP 290	29.1	1.77	150	2150	160	2300	170	2450	2500
2XP 310	31.5	1.92	130	1850	140	2000	150	2150	2500

NEW

Dimensions

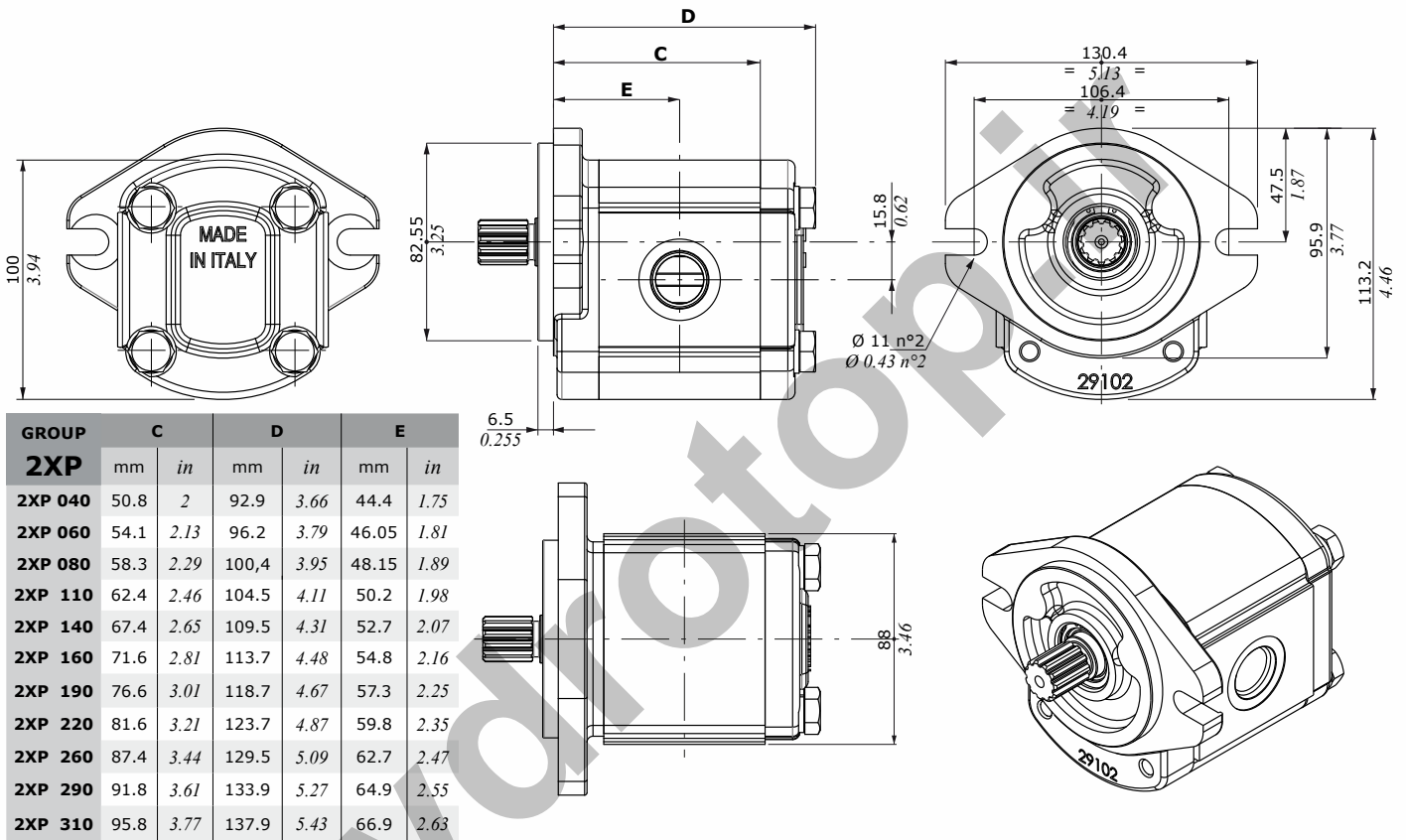

The dimensional drawing represents the version with **SAEA** flange (for other flanges, see the next page).

Cover with ports for rear connection

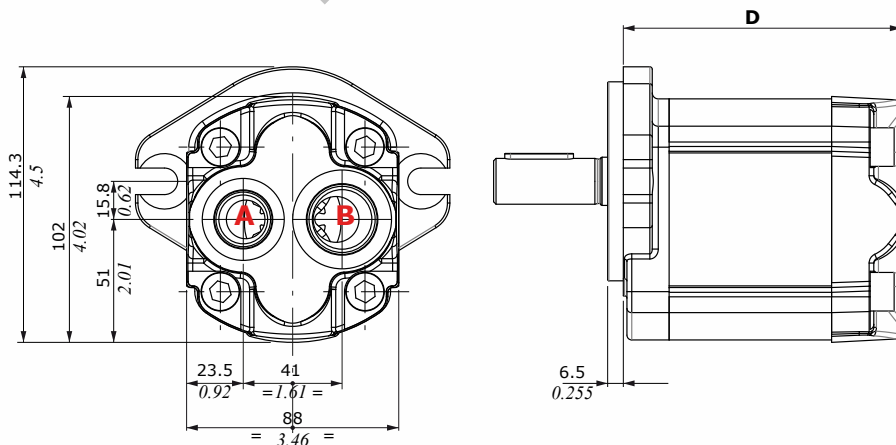

GROUP	D	
	mm	in
2XP 040	98.8	3.89
2XP 060	102.1	4.02
2XP 080	106.3	4.18
2XP 110	110.4	4.34
2XP 140	115.4	4.54
2XP 160	119.6	4.70
2XP 190	124.6	4.90
2XP 220	129.6	5.10
2XP 260	135.4	5.33
2XP 290	139.8	5.50
2XP 310	143.8	5.66

NOTE: the ports can be present both or individually, of the same or different sizes



2XP

Aluminum Gear Pump

Dimensions

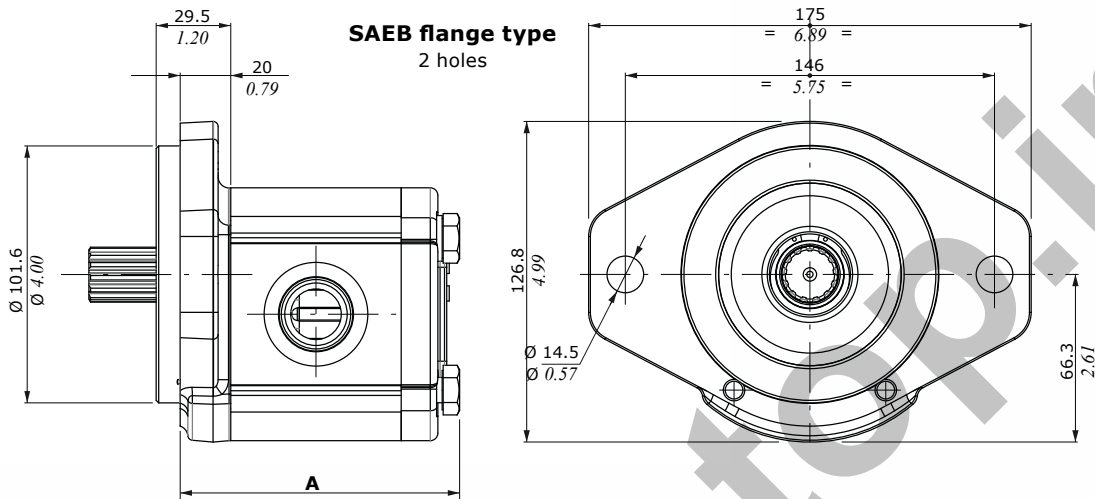

GROUP 2XP	A	
	mm	in
2XP 040	93.9	3.70
2XP 060	97.2	3.82
2XP 080	101.4	3.99
2XP 110	105.5	4.15
2XP 140	110.5	4.35
2XP 160	114.7	4.51
2XP 190	119.7	4.71
2XP 220	124.7	4.91
2XP 260	130.5	5.14
2XP 290	134.9	5.31
2XP 310	138.9	5.47

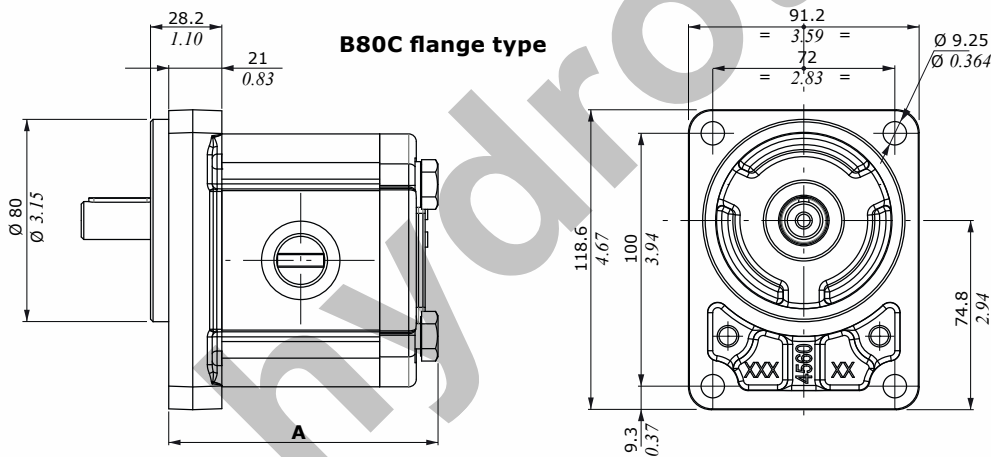

GROUP 2XP	A	
	mm	in
2XP 040	94.9	3.74
2XP 060	98.2	3.87
2XP 080	102.4	4.03
2XP 110	106.5	4.19
2XP 140	111.5	4.39
2XP 160	115.7	4.55
2XP 190	120.7	4.75
2XP 220	125.7	4.95
2XP 260	131.5	5.18
2XP 290	135.9	5.35
2XP 310	139.9	5.50

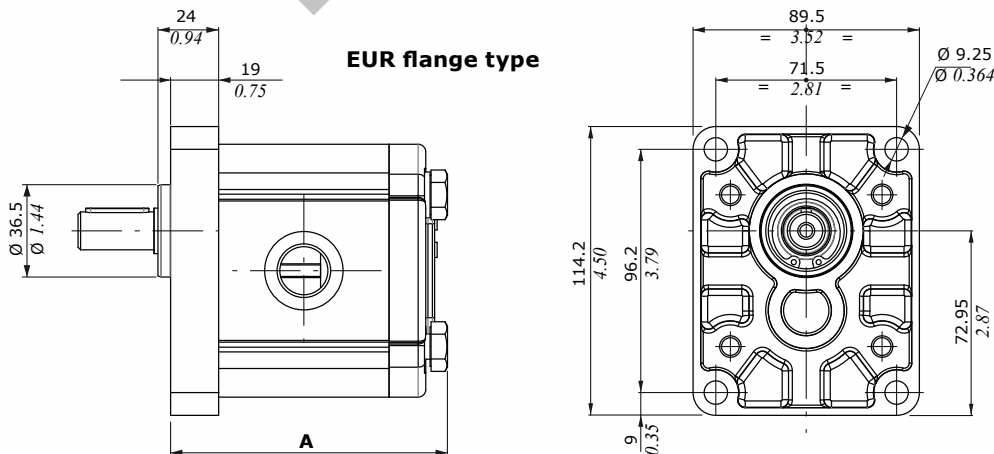

GROUP 2XP	A	
	mm	in
2XP 040	92.9	3.66
2XP 060	96.2	3.79
2XP 080	100.4	3.95
2XP 110	104.5	4.11
2XP 140	109.5	4.31
2XP 160	113.7	4.48
2XP 190	118.7	4.67
2XP 220	123.7	4.87
2XP 260	129.5	5.10
2XP 290	133.9	5.27
2XP 310	137.9	5.43

NEW

Configurations

Single pump:

2XP

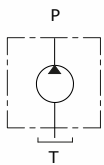
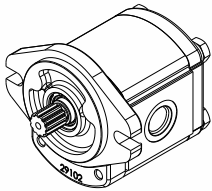

Double pump:

2XP + 1SP

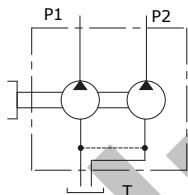
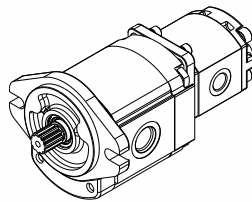

Double pump:

2XP + 2XP

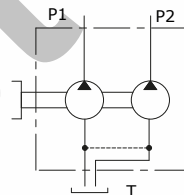
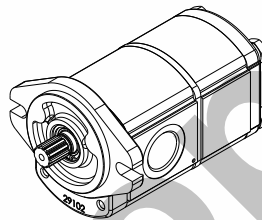

NOTE: for separate stage solutions please contact Sales Department

Single pump with back cover with auxiliary function:

2XP + AUX

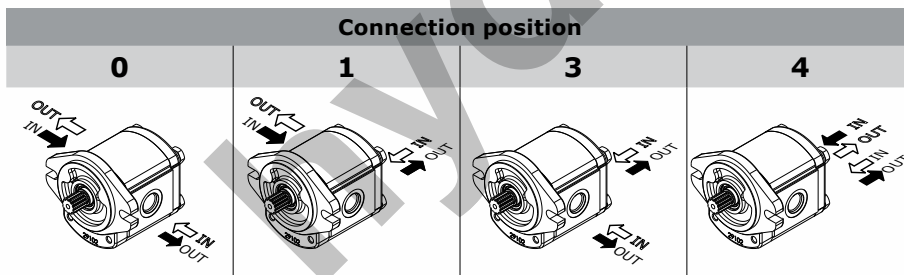
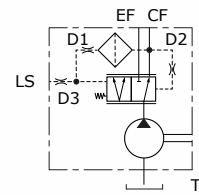
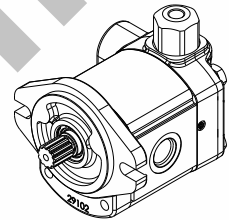

Clockwise rotation - **D**

Anti-clockwise rotation - **S**

Auxiliary valves available

VLPI	Pressure relief valve (internal drain)
VLPE	Pressure relief valve (external drain)
VRF	Flow regulator
VRFLPI	Flow divider and relief valve
UNLD	Unloading valve
CP (LS)	Priority valve

Portings and connections	porting type				
	G	U	T	N	F
0	●	●	●	●	●
1	●	●	-	-	-
3	●	●	-	-	-
4	●	●	-	-	-

(-): for available connection, please contact our Sales Dpt.

2XP

Aluminum Gear Pump

Ports and connections

G: BSP

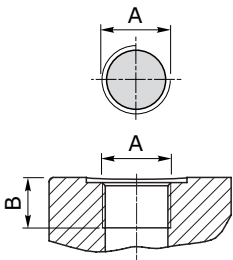

U: UN-UNF

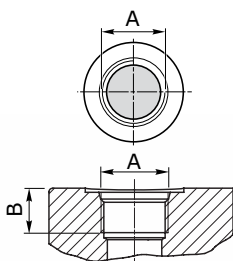

N: European flange

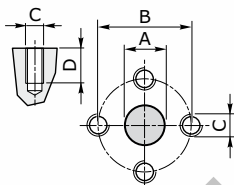

T: German flange

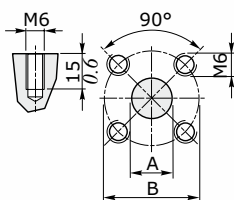

F: SAE J518-1 connection

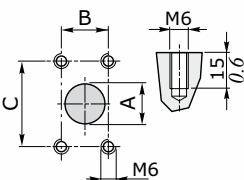

GROUP 2XP	Port Threading											
	G (BSP)						U (UN-UNF)					
	A		B		A		B		A		B	
IN	OUT	IN	OUT	IN	OUT	IN	OUT	IN	OUT	IN	OUT	
		mm	in	mm	in	mm	in	mm	in	mm	in	
2XP 040	G 1/2"	G 1/2"	16	0.63	16	0.63	SAE10	SAE10	17	0.67	17	0.67
2XP 060	G 1/2"	G 1/2"	16	0.63	16	0.63	SAE10	SAE10	17	0.67	17	0.67
2XP 080	G 1/2"	G 1/2"	16	0.63	16	0.63	SAE10	SAE10	17	0.67	17	0.67
2XP 110	G 3/4"	G 1/2"	17	0.67	16	0.63	SAE12	SAE10	20	0.79	17	0.67
2XP 140	G 3/4"	G 1/2"	17	0.67	16	0.63	SAE12	SAE10	20	0.79	17	0.67
2XP 160	G 3/4"	G 1/2"	17	0.67	16	0.63	SAE12	SAE10	20	0.79	17	0.67
2XP 190	G 3/4"	G 1/2"	17	0.67	16	0.63	SAE12	SAE10	20	0.79	17	0.67
2XP 220	G 3/4"	G 1/2"	17	0.67	16	0.63	SAE16	SAE10	20	0.79	17	0.67
2XP 260	G 3/4"	G 1/2"	17	0.67	16	0.63	SAE16	SAE10	20	0.79	17	0.67
2XP 290	G 3/4"	G 1/2"	17	0.67	16	0.63	SAE16	SAE10	20	0.79	17	0.67
2XP 310	G 3/4"	G 1/2"	17	0.67	16	0.63	SAE16	SAE10	20	0.79	17	0.67

GROUP 2XP	Port Threading												Port Threading									
	N (EUROPEAN)												T (GERMAN)									
	A		B		C		D		A		B		A		B							
Ø IN	Ø OUT	Ø IN	Ø OUT	Ø IN	Ø OUT	Ø IN	Ø OUT	Ø IN	Ø OUT	Ø IN	Ø OUT	Ø IN	Ø OUT	Ø IN	Ø OUT							
mm	in	mm	in	mm	in	mm	in	mm	in	mm	in	mm	in	mm	in							
2XP 040	13	0.51	13	0.51	30	1.18	30	1.18	M6	M6	15	0.59	15	0.59	20	0.79	15	0.59	40	1.57	35	1.38
2XP 060	13	0.51	13	0.51	30	1.18	30	1.18	M6	M6	15	0.59	15	0.59	20	0.79	15	0.59	40	1.57	35	1.38
2XP 080	13	0.51	13	0.51	30	1.18	30	1.18	M6	M6	15	0.59	15	0.59	20	0.79	15	0.59	40	1.57	35	1.38
2XP 110	19	0.75	13	0.51	40	1.57	30	1.18	M8	M6	14	0.55	15	0.59	20	0.79	15	0.59	40	1.57	35	1.38
2XP 140	19	0.75	13	0.51	40	1.57	30	1.18	M8	M6	14	0.55	15	0.59	20	0.79	15	0.59	40	1.57	35	1.38
2XP 160	19	0.75	13	0.51	40	1.57	30	1.18	M8	M6	14	0.55	15	0.59	20	0.79	15	0.59	40	1.57	35	1.38
2XP 190	19	0.75	13	0.51	40	1.57	30	1.18	M8	M6	14	0.55	15	0.59	20	0.79	15	0.59	40	1.57	35	1.38
2XP 220	19	0.75	13	0.51	40	1.57	30	1.18	M8	M6	14	0.55	15	0.59	20	0.79	15	0.59	40	1.57	35	1.38
2XP 260	19	0.75	13	0.51	40	1.57	30	1.18	M8	M6	14	0.55	15	0.59	20	0.79	15	0.59	40	1.57	35	1.38
2XP 290	19	0.75	13	0.51	40	1.57	30	1.18	M8	M6	14	0.55	15	0.59	20	0.79	15	0.59	40	1.57	35	1.38
2XP 310	19	0.75	13	0.51	40	1.57	30	1.18	M8	M6	14	0.55	15	0.59	20	0.79	15	0.59	40	1.57	35	1.38

GROUP 2XP	Port Threading											
	F (SAE J518-1 connection)											
	A		B		C		A		B		C	
Ø IN	Ø OUT	Ø IN	Ø OUT	Ø IN	Ø OUT	Ø IN	Ø OUT	Ø IN	Ø OUT	Ø IN	Ø OUT	
mm	in	mm	in	mm	in	mm	in	mm	in	mm	in	
2XP 040	20	0.79	15	0.59	17.4	0.69	17.4	0.69	38	1.50	38	1.50
2XP 060	20	0.79	15	0.59	17.4	0.69	17.4	0.69	38	1.50	38	1.50
2XP 080	20	0.79	15	0.59	17.4	0.69	17.4	0.69	38	1.50	38	1.50
2XP 110	20	0.79	15	0.59	17.4	0.69	17.4	0.69	38	1.50	38	1.50
2XP 140	26	1.02	15	0.59	22.4	0.88	17.4	0.69	47.6	1.87	38	1.50
2XP 160	26	1.02	15	0.59	22.4	0.88	17.4	0.69	47.6	1.87	38	1.50
2XP 190	26	1.02	15	0.59	22.4	0.88	17.4	0.69	47.6	1.87	38	1.50
2XP 220	26	1.02	15	0.59	22.4	0.88	17.4	0.69	47.6	1.87	38	1.50
2XP 260	26	1.02	15	0.59	22.4	0.88	17.4	0.69	47.6	1.87	38	1.50
2XP 290	26	1.02	15	0.59	22.4	0.88	17.4	0.69	47.6	1.87	38	1.50
2XP 310	26	1.02	15	0.59	22.4	0.88	17.4	0.69	47.6	1.87	38	1.50

NEW

Shaft types

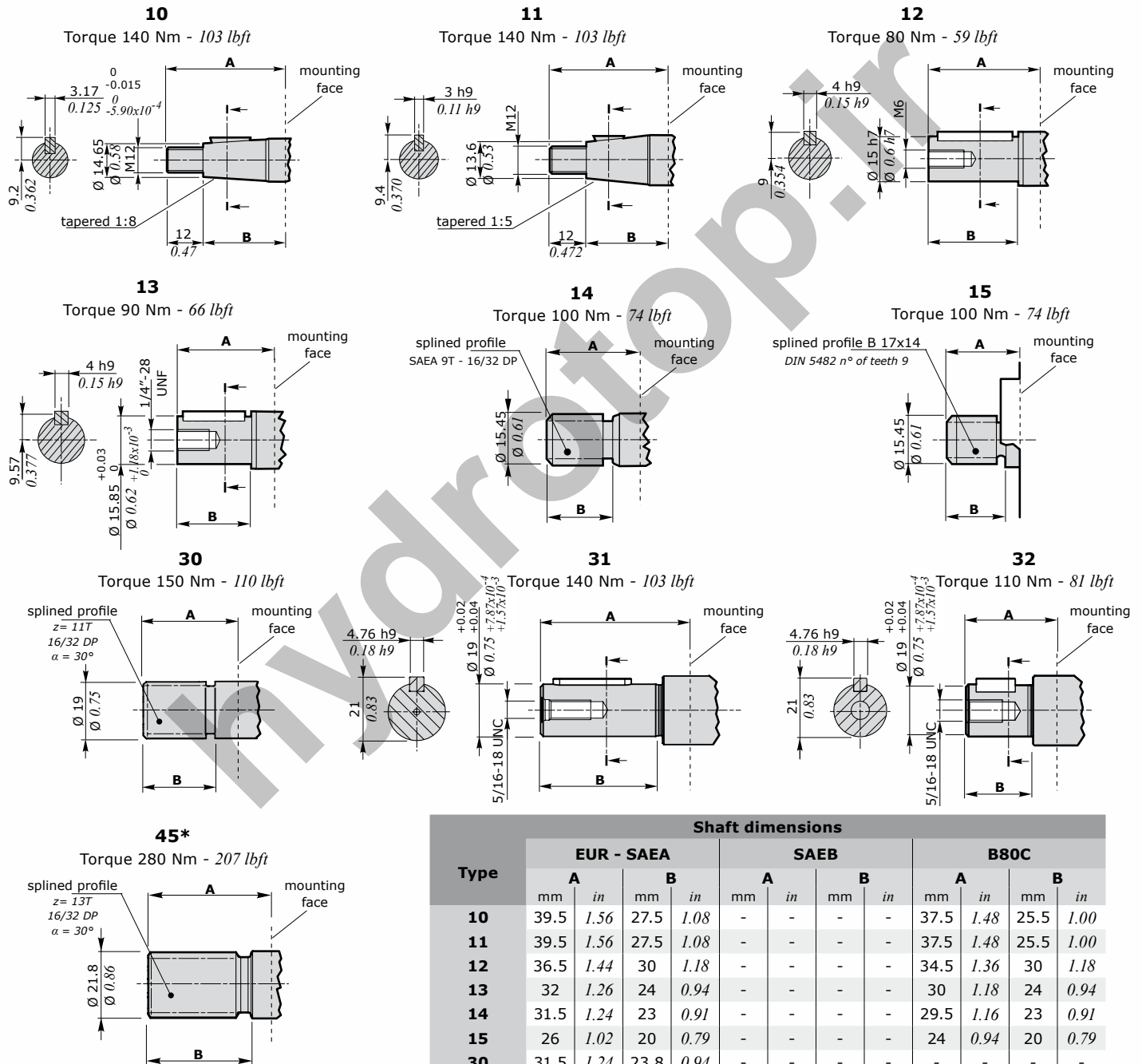

(*) Only for pump with SAEB flange

Type	Shaft dimensions											
	EUR - SAEA				SAEB				B80C			
	A		B		A		B		A		B	
mm	in	mm	in	mm	in	mm	in	mm	in	mm	in	
10	39.5	1.56	27.5	1.08	-	-	-	-	37.5	1.48	25.5	1.00
11	39.5	1.56	27.5	1.08	-	-	-	-	37.5	1.48	25.5	1.00
12	36.5	1.44	30	1.18	-	-	-	-	34.5	1.36	30	1.18
13	32	1.26	24	0.94	-	-	-	-	30	1.18	24	0.94
14	31.5	1.24	23	0.91	-	-	-	-	29.5	1.16	23	0.91
15	26	1.02	20	0.79	-	-	-	-	24	0.94	20	0.79
30	31.5	1.24	23.8	0.94	-	-	-	-	-	-	-	-
31	53.8	2.12	44.5	1.75	-	-	-	-	-	-	-	-
32	31	1.22	24	0.94	-	-	-	-	-	-	-	-
45*	-	-	-	-	41.2	1.62	34	1.34	-	-	-	-

Shaft - flange combination

GROUP	Shaft type									
	10 Tapered 1:8	11 Tapered 1:5	12 EUR parallel shaft	13 SAEA parallel shaft	14 SAEA 9T splined	15 DIN5482 9T (26/24) splined	30 SAE 11T splined	31 SAE Ø19 (53.8 mm - 2.12 in) parallel shaft	32 SAE Ø19 (31 mm - 1.22 in) parallel shaft	45 SAEB 13T splined
SAEA	●	●	●	◆	◆	●	◆	◆	●	-
SAEB 2F	●	●	●	●	●	●	-	-	-	◆
B80C	●	◆	◆	●	●	◆	-	-	-	-
EUR	◆	●	◆	●	●	●	-	-	-	-

◆ = STANDARD COMBINATION
● = AVAILABLE COMBINATION

Description composition

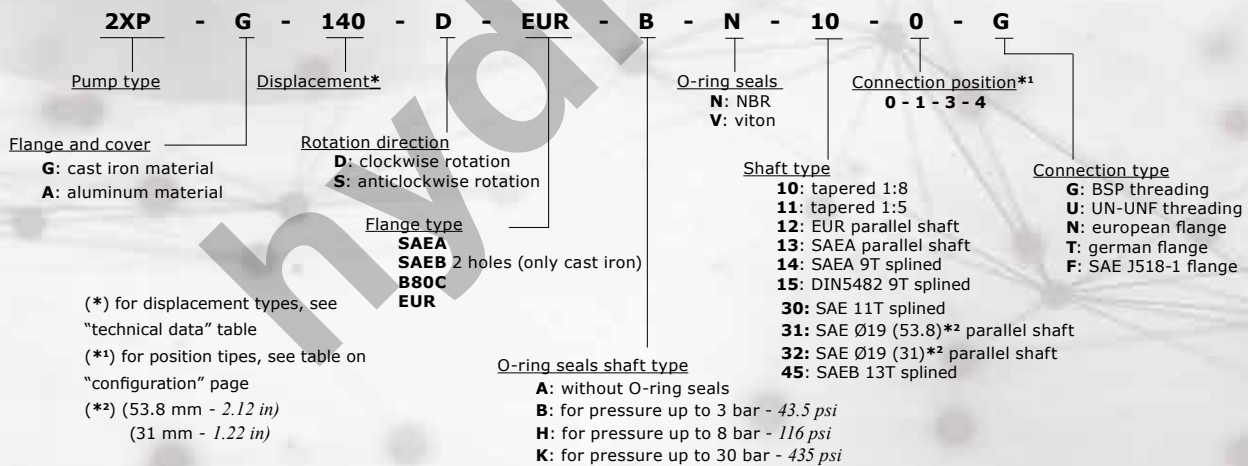

2XP+2XP configuration example

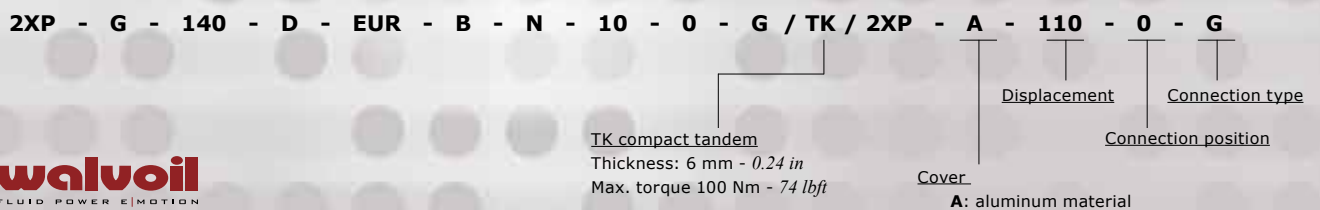

D1WGCM05E - 1st edition April 2021

