

EIPH2
EIPH3
EIPH5
EIPH6

Internal gear pumps

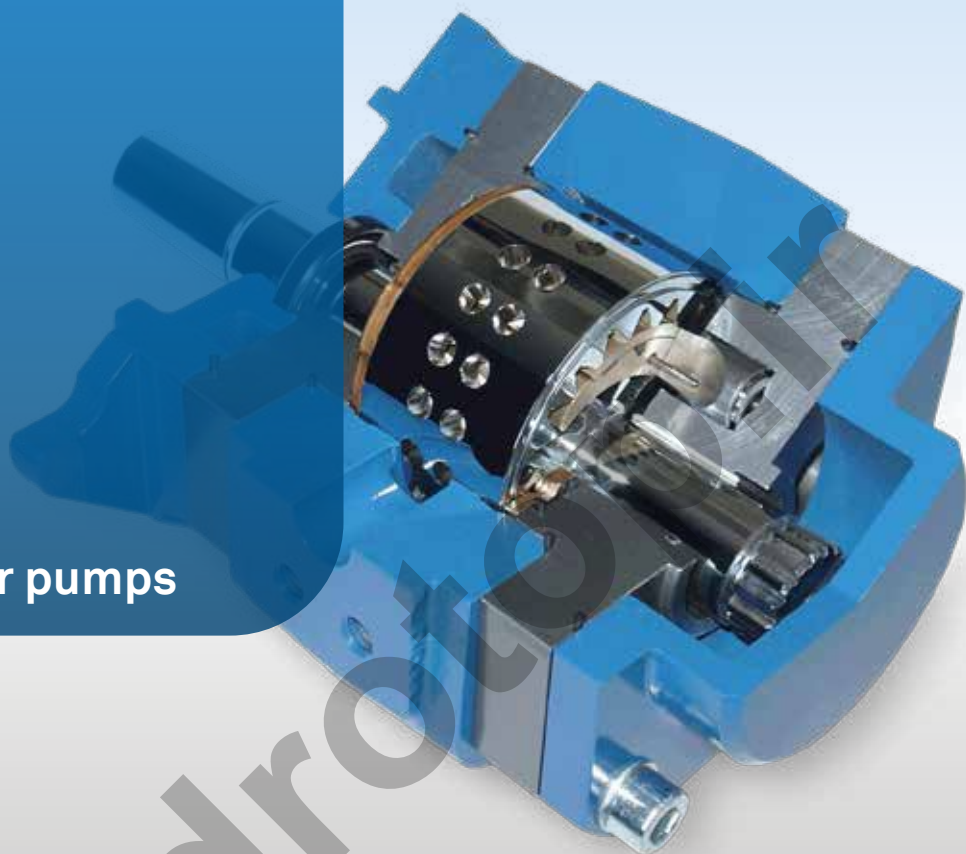

Internal gear pump

Type EIPH2 high pressure pump with constant displacement volume

EIPH2

Characteristics

- Internal gear pump with axial and radial gap compensation
- Radial compensation with segments
- Suction and pressure port radial
- Field of application: Industrial hydraulic
- Low noise
- Long time life
- Low pulsation (pressure pulsation ~2 %)
- Multi flow combinations

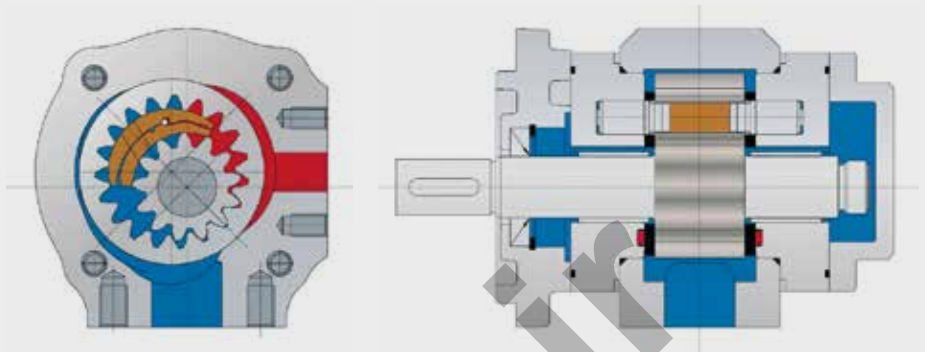

Technical Data:

Rated Size	004	005	006	008	011	013	016	019	022	025
Spec. volume Vth [cm ³ /rev]**	4,2	5,4	6,4	7,8	10,8	13,3	15,6	18,9	21,8	24,8
Continuous operating pressure [bar]**				330			300			250
Peak operating pressure [bar] max. 10 sec. 15% duty cycle**				350			300			280
Cut-in pressure peak [bar]**				400			325			300
Nominal speed [min ⁻¹]	400 – 3.600			400 – 3.400	400 – 3.200		400 – 3.000	400 – 2.500		400 – 2.300
Max. speed [min ⁻¹]	4.200			4.000			3.000			
Nominal speed [min ⁻¹ ****	For rated size 019 available							400 – 3.000		400 – 2.800
Max. speed [min ⁻¹ ****	For rated size 019 available							3.600		
Operating viscosity [mm ² /s]						10 – 300				
Starting viscosity [mm ² /s]						2.000				
Operating medium						HL – HLP DIN 51 524 part 1/2				
Max. medium temperature [°C]						80				
Min. medium temperature [°C]						-20				
Max. ambient temperature [°C]						80				
Min. ambient temperature [°C]						-20				
Max. admission pressure (intake side) [bar]						2 bar absolute				
Min. admission pressure (intake side) [bar]						0,8 bar absolute (Start 0,6)				
Weight appr. [kg]	4,9		5,0	5,2	5,4	5,5	5,7	7,4	7,8	8
Degree of filtration	Class 20/18/15 due to ISO 4406									
Life expectancy	not less than 1x 10 ⁷ load cycles against peak operating pressure									
Efficiency η vol:	88	91	92	93		94		95		
Efficiency η hm:	85	90		91	92		93			
Pump noise* (measured in sound chamber) dB[A]	53	54	55	57	58	59	60	61	62	63

n = 1.450 min⁻¹ Δ p = 250 bar T = 50 °C Medium: HLP 46 Bruggler value min. 30N/mm² recommended 50N/mm² for servo applications

* Measured in anechoic room of Eckerle Hydraulic Division; Axial microphone distance 1.0 m

** For acceptable pressure at 400-1.800 rpm. Further rpm on request.

*** Due to manufacturing tolerances the displacement volume could vary.

**** 1 1/2" suction port

The pumps have no corrosion protection.

The max. permissible values must not be applied cumulatively. Please contact us.

Internal gear pump

Type EIPH3 high pressure pump

with constant displacement volume

EIPH3

Characteristics

The series EIPH were developed particularly for the high requirements of industrial hydraulics. Their favourable noise characteristic, extremely low delivery and pressure pulsation, outstanding efficiency within broad revolution and viscosity ranges, have firmly established gap-compensated high pressure internal gear pumps among high pressure pumps. Simple combinability to multiple pumps with separate or common inlet is given.

The EIPH is a consistent advancement that already for over 40 years in the industry used gap-compensated internal gear pump technology, System Eckerle.

Technical Data:

Rated Size	014	016	020	025	032	040	050	064
Spec. volume Vth [cm ³ /rev]**	14,3	15,8	20,0	24,5	31,6	39,5	49,5	65,3
Continuous operating pressure [bar]**	330			330			280	
Peak operating pressure [bar] max. 10 sec. 15% duty cycle**	350			350			300	
Cut-in pressure peak [bar]**	400			400			325	
Nominal speed [min ⁻¹]	400 – 3.600		400 – 3.400	400 – 3.200	400 – 3.000	400 – 2.500	400 – 1.800	
Max. speed [min ⁻¹]	4.000		3.400	3.200	3.000	2.500	1.800	
Nominal speed [min ⁻¹ ****	For rated size 040-064 available			400 – 3.200	400 – 3.200	400 – 3.200	400 – 3.000	400 – 2.200
Max. speed [min ⁻¹ ****	For rated size 040-064 available			4.000	3.600	3.600		2.500
Operating viscosity [mm ² /s]	10 – 300							
Starting viscosity [mm ² /s]	2.000							
Operating medium	HL – HLP DIN 51 524 part 1/2							
Max. medium temperature [°C]	80							
Min. medium temperature [°C]	-20							
Max. ambient temperature [°C]	80							
Min. ambient temperature [°C]	-20							
Max. admission pressure (intake side) [bar]	2 bar absolute							
Min. admission pressure (intake side) [bar]	0,8 bar absolute (Start 0,6)							
Weight appr. [kg]	9,4	10,1	10,5	11,2	12,0	15	17	18
Degree of filtration	Class 20/18/15 due to ISO 4406							
Life expectancy	not less than 1x 10 ⁷ load cycles against peak operating pressure							
Efficiency η vol:	91	92	93		94	95		
Efficiency η hm:	90		91	92		93		
Pump noise* (measured in sound chamber) dB[A]	60	61	62	63	64	65	66	

n = 1.450 min⁻¹ Δ p = 250 bar T = 50 °C Medium: HLP 46

* Measured in anechoic room of Eckerle Hydraulic Division; Axial microphone distance 1.0 m

** For acceptable pressure at 400-1.800 rpm. Further rpm on request.

*** Due to manufacturing tolerances the displacement volume could vary.

**** 1½" suction port for rated size 025/032; 2" suction port for rated size 040/050/064

The pumps have no corrosion protection.

The max. permissible values must not be applied cumulatively. Please contact us.

Internal gear pump

Type EIPH5 high pressure pump

with constant displacement volume

EIPH5

Technical Data:

Rated Size	040	050	064	080	100
Spec. volume Vth [cm ³ /rev]**	40,2	50,3	65,3	80,4	100,5
Continuous operating pressure [bar]**	300	300		280	
Peak operating pressure [bar] max. 10sec 15% duty cycle**	330	330		290	
Cut-in pressure peak [bar]**	350	350		300	
Nominal speed [rpm]	100 – 3.000	100 – 3.000		100 – 2.800	100 – 2.500
Max. speed [rpm]	3.600	3.600		3.000	
Operating viscosity [mm ² /s]				10 – 300	
Starting viscosity [mm ² /s]				2.000	
Operating medium				HL – HLP DIN 51 524 part 1/2	
Max. medium temperature [°C]				80	
Min. medium temperatur [°C]				-20	
Max. ambient temperature [°C]				80	
Min. ambient temperature [°C]				-20	
Max. admission pressure (intake side) [bar]				2 bar absolute	
Min. admission pressure (intake side) [bar]				0,8 bar absolute (Start 0,6)	
Weight appr. [kg]:	12,9	14,0	15,3	17,5	18,7
Degree of filtration				Class 20/18/15 due to ISO 4406	
Life expectancy				not less than 1x 10 ⁷ load cycles against peak operating pressure	
Efficiency η vol:	93	93	94	95	95
Efficiency η hm:	92	92	92	93	93
Pump noise* (measured in sound chamber) dB[A]	67	68	69	70	71

n = 1.450 min⁻¹ Δ p = 250 bar T = 50 °C Medium: HLP 46

* Measured in anechoic room of Eckerle Hydraulic Division; Axial microphone distance 1.0 m

** For acceptable pressure at 400-1.800 rpm. Further rpm on request.

*** Due to manufacturing tolerances the displacement volume could vary.

The pumps have no corrosion protection. The max. permissible values must not be applied cumulatively. Please contact us.

Internal gear pump

Type EIPH6 high pressure pump with constant displacement volume

EIPH6

Technical Data:

Rated Size	040	050	064	080	100	125	160	200	250
Spec. volume Vth [cm ³ /rev]***	40,8	50,6	65,3	80,0	101,2	125,7	160,1	200,9	249,9
Continuous operating pressure [bar]**	330		315		300		250	160	140
Peak operating pressure [bar] max. 10sec 15% duty cycle**	340			330			280	210	150
Cut-in pressure peak [bar]**	350			340			300	220	160
Nominal speed [rpm]	400 – 2.200					400 – 2.000		400 – 1.800	
Max. speed [rpm]	2.400					2.200		2.000	
Operating viscosity [mm ² /s]					10 – 300				
Starting viscosity [mm ² /s]					2.000				
Operating medium	HL – HLP DIN 51 524 part 1/2								
Max. medium temperature [°C]					80				
Min. medium temperatur [°C]					-20				
Max. ambient temperature [°C]					80				
Min. ambient temperature [°C]					-20				
Max. admission pressure (intake side) [bar]	2 bar absolute								
Min. admission pressure (intake side) [bar]	0,8 bar absolute (Start 0,6)								
Weight appr. [kg]:	31	32	34	36	39	42	46	51	58
Degree of filtration	Class 20/18/15 due to ISO 4406								
Life expectancy	not less than 1x 10 ⁷ load cycles against peak operating pressure								
Efficiency η vol:	93		94		95		96		
Efficiency η hm:	89			90			91		
Pump noise* (measured in sound chamber) dB[A]	72	73	74	75	76		77		78

n = 1.450 min⁻¹ Δ p = 250 bar T = 50 °C Medium: HLP 46

* Measured in anechoic room of Eckerle Hydraulic Division; Axial microphone distance 1.0 m

** For acceptable pressure at 400-1.800 rpm. Further rpm on request.

*** Due to manufacturing tolerances the displacement volume could vary.

The pumps have no corrosion protection. The max. permissible values must not be applied cumulatively. Please contact us.

Pump with SAE-A2-bolt flange and straight keyed shaft

Order example: EIPH2-___RK03-1X

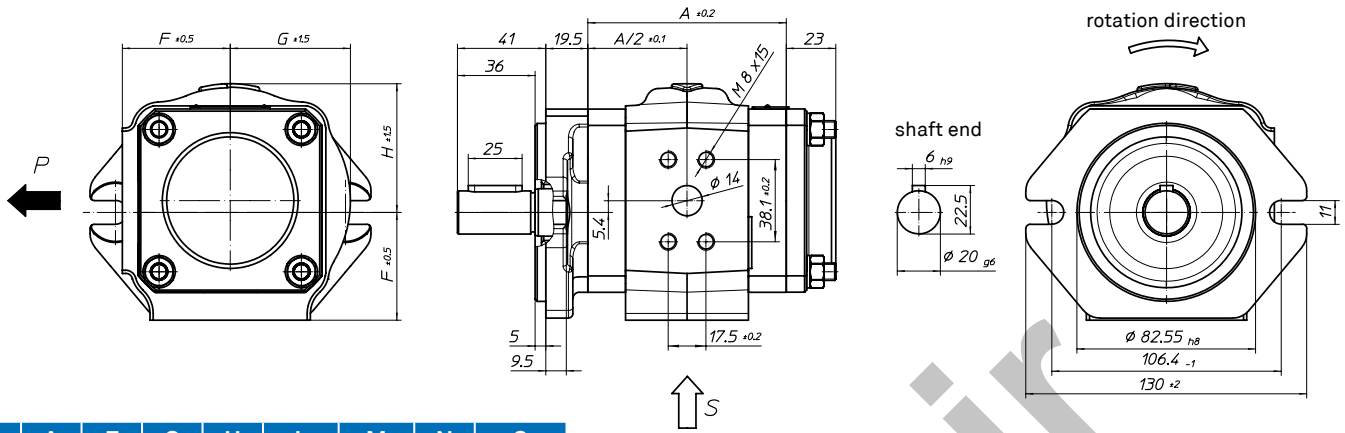

Size	A	F	G	H	L	M	N	O
004	71	50	55	59	38,1	17,5	14	M8x15
005	71	50	55	59	38,1	17,5	14	M8x15
006	73	50	55	59	47,5	22	19	M10x16
008	76	50	55	59	47,5	22	19	M10x17
011	82	50	55	59	52,4	26,2	25	M10x17
013	87	50	55	60	52,4	26,2	25	M10x17
016	92	50	55	60	52,4	26,2	25	M10x17
019	99	55	61	65	52,4	26,2	25	M10x17
022	105	55	61	65	52,4	26,2	25	M10x17
025	111	55	61	65	52,4	26,2	25	M10x17

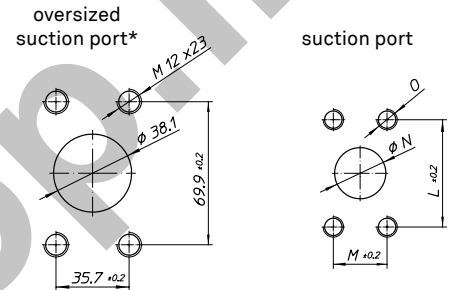

* is suitable for speed controlled drive applications (available only for sizes 019, 022, 025)

Double pump with SAE-A2-bolt flange and straight keyed shaft

Order example: EIPH2-___RK00-1X+ EIPH2-___RP30-1X

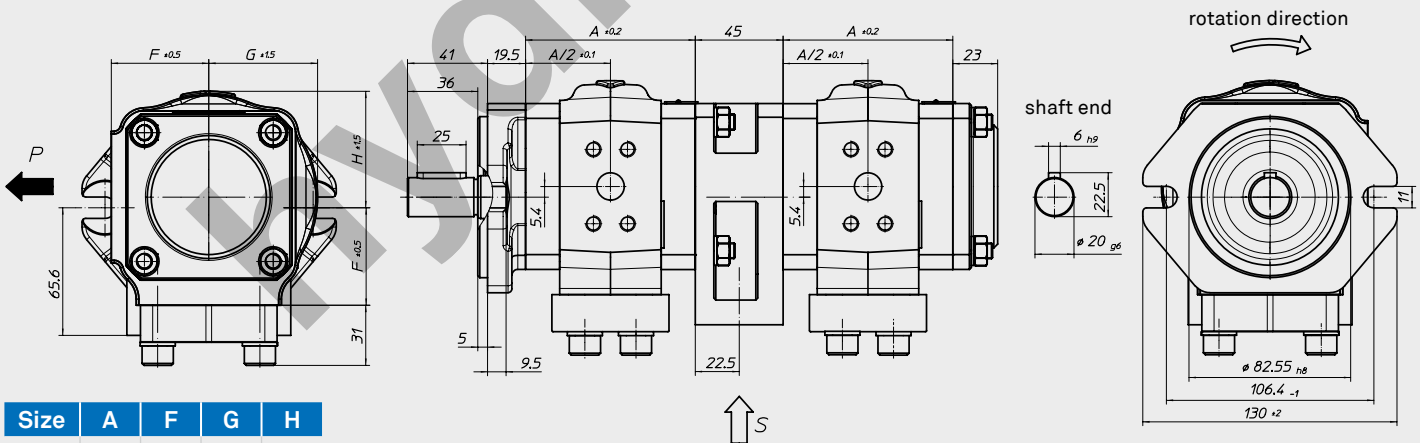

Size	A	F	G	H
004	71	50	55	59
005	71	50	55	59
006	73	50	55	59
008	76	50	55	59
011	82	50	55	59
013	87	50	55	60
016	92	50	55	60
019	99	55	61	65
022	105	55	61	65
025	111	55	61	65

Intermediate suction port
 primary pump size 004-016
 primary pump size 019-025

Pressure connections see single pumps | For separate suction, see suction connections single pumps.

Pump with SAE-B2-bolt flange and straight keyed shaft

Order example: EIPH3-___RK23-1X

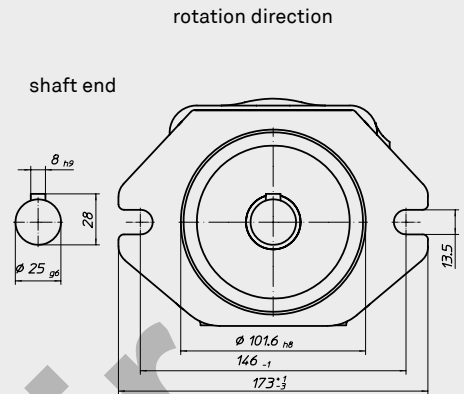
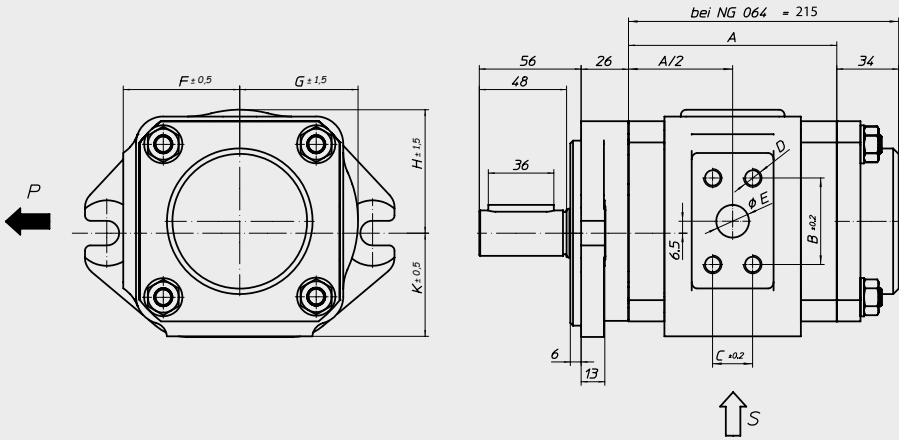

Size	A	B	C	D	E	F	G	H	K	L	M	N	O
014	90,4	38,1	17,5	M8x15	14	64	65	67	57	52,4	26,2	25	M10x17
016	92,4	38,1	17,5	M8x15	14	64	65	67	57	52,4	26,2	25	M10x17
020	97,9	47,5	22	M10x17	18	64	65	67	57	58,7	30,2	32	M10x17
025	104,4	47,5	22	M10x17	18	64	65	67	57	58,7	30,2	32	M10x17
032	114,4	47,5	22	M10x17	18	64	65	67	57	58,7	30,2	32	M10x17
040	125,4	52,4	26,2	M10x17	20	70	73	81	63	58,7	30,2	32	M10x20
050	139,4	52,4	26,2	M10x17	20	70	73	81	63	58,7	30,2	32	M10x20
064		52,4	26,2	M10x17	20	70	73	81	63	58,7	30,2	32	M10x20

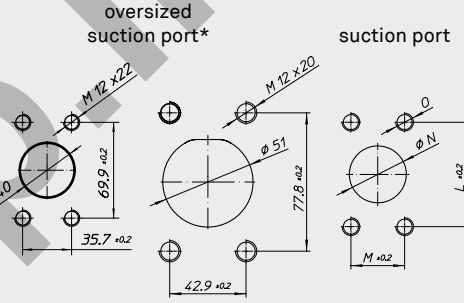

Double pump with SAE-B2-bolt flange and straight keyed shaft

Order example: EIPH3-___RK20-1X+
EIPH3-___RP30-1X

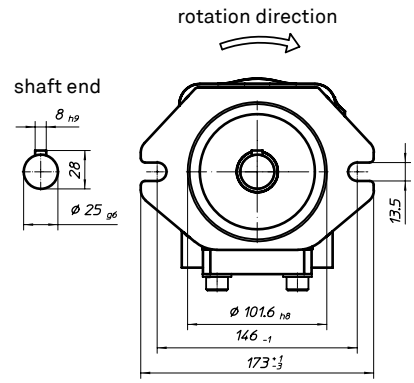
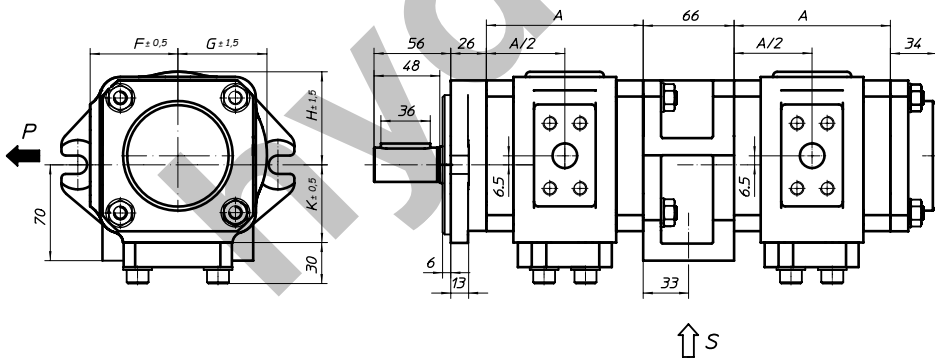

Size	A	F	G	H	K
014	90,4	64	65	67	57
016	92,4	64	65	67	57
020	97,9	64	65	67	57
025	104,4	64	65	67	57
032	114,4	64	65	67	57
040	125,4	70	73	81	63
050	139,4	70	73	81	63

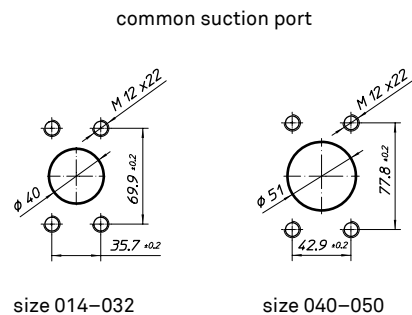

Pressure connections see single pump | For separate suction, see suction connections single pumps.

Double pump with SAE-B2-bolt flange and straight keyed shaft

Order example: EIPH3-___RK20-1X+
EIPH2-___RP30-1X

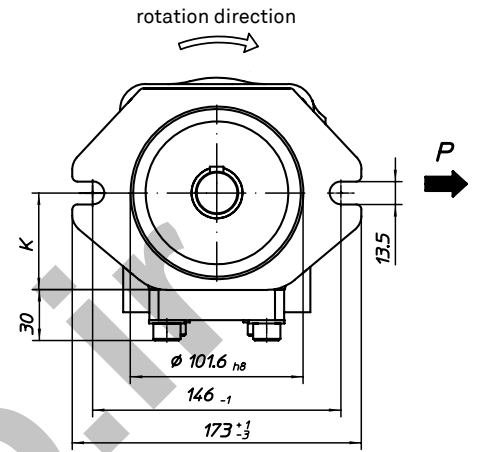
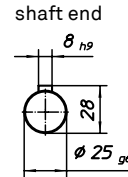
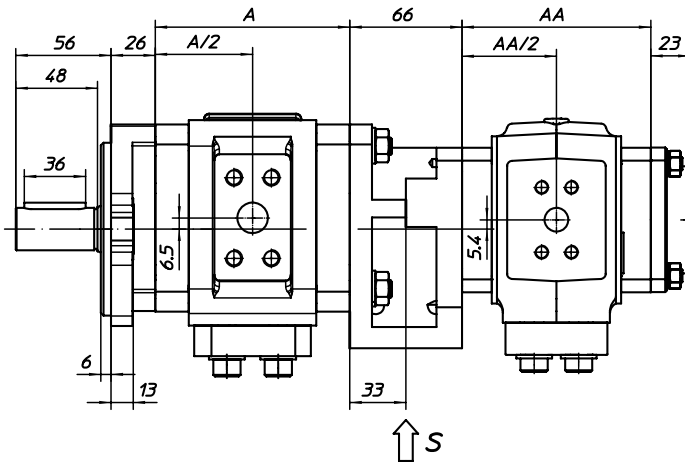

EIPH3

Size	A	F	G	H
014	90,4	64	65	67
016	92,4	64	65	67
020	97,9	64	65	67
025	104,4	64	65	67
032	114,4	64	65	67
040	125,4	70	73	81
050	139,4	70	73	81

EIPH2

Size	AA	FF	GG	HH
004	71	50	55	59
005	71	50	55	59
006	73	50	55	59
008	76	50	55	59
011	82	50	55	59
013	87	50	55	60
016	92	50	55	60
019	99	55	61	65
022	105	55	61	65
025	111	55	61	65

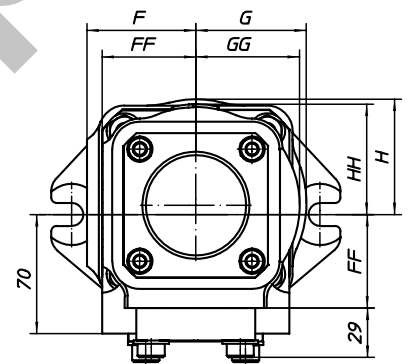

Pressure connections see single pumps
For separate suction, see suction connections single pumps.

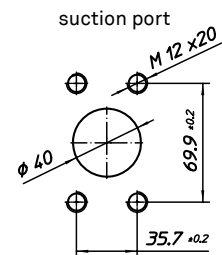

The single pumps of a multiple pump assembly are internally connected, even if you connect to the pump inlet. It is therefore no operating with different fluids possible.

Pump with SAE-C2-bolt flange and straight keyed shaft

Order example: EIPH5-___RA23-1X

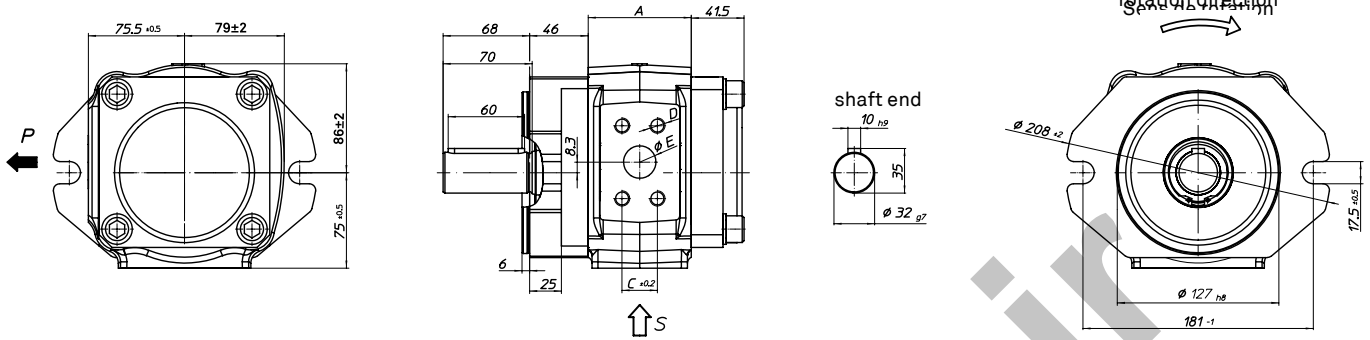

EIPH5

NG	A	B*	C*	D	E	L**	M**	N
040	61	57,2	27,8	M12x24	25,4	77,8	42,9	51
050	69	57,2	27,8	M12x24	25,4	77,8	42,9	51
064	81	57,2	27,8	M12x24	25,4	77,8	42,9	51
080	93	66,7	31,8	M14x24	31,8	77,8	42,9	51
100	109	66,7	31,8	M14x24	31,8	88,9	50,8	63,5

* Pressure port: SAE J518, high pressure series (code 62)

** Suction port: SAE J518, standard pressure series (code 61)

suction port

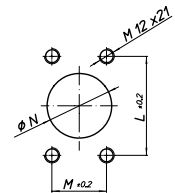

Pump with SAE-C2-bolt flange and splined shaft

Order example: EIPH5-___RB23-1X

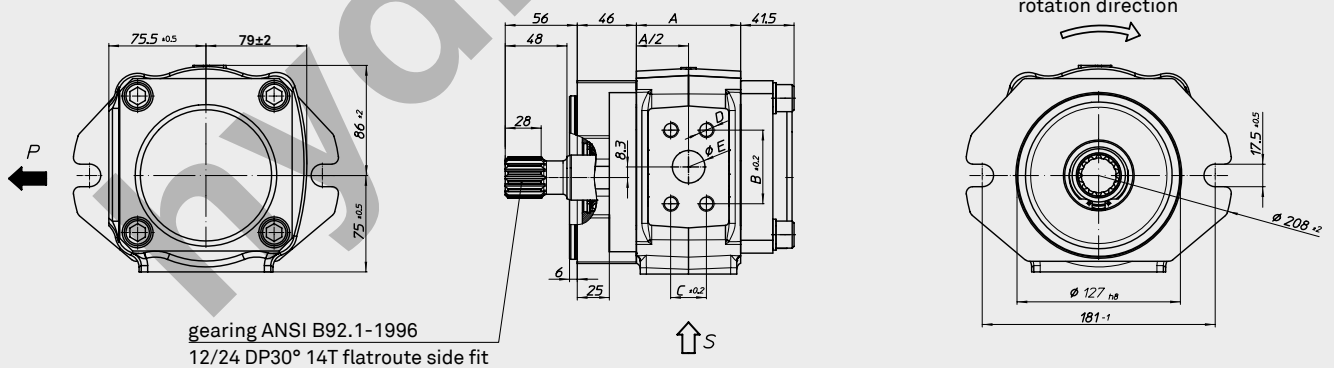

gearing ANSI B92.1-1996
12/24 DP30° 14T flatroute side fit

EIPH5

Size	A	B*	C*	D	E	L**	M**	N
040	61	57,2	27,8	M12x24	25,4	77,8	42,9	51
050	69	57,2	27,8	M12x24	25,4	77,8	42,9	51
064	81	57,2	27,8	M12x24	25,4	77,8	42,9	51
080	93	66,7	31,8	M14x24	31,8	77,8	42,9	51
100	109	66,7	31,8	M14x24	31,8	88,9	50,8	63,5

* Pressure port: SAE J518, high pressure series (code 62)

** Suction port: SAE J518, standard pressure series (code 61)

suction port S

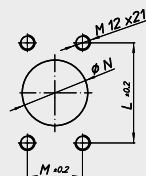

Double pump with SAE-C2-bolt flange and straight keyed shaft

Order example: EIPH5-___SK23-1X+
EIPH3-___RP33-1X

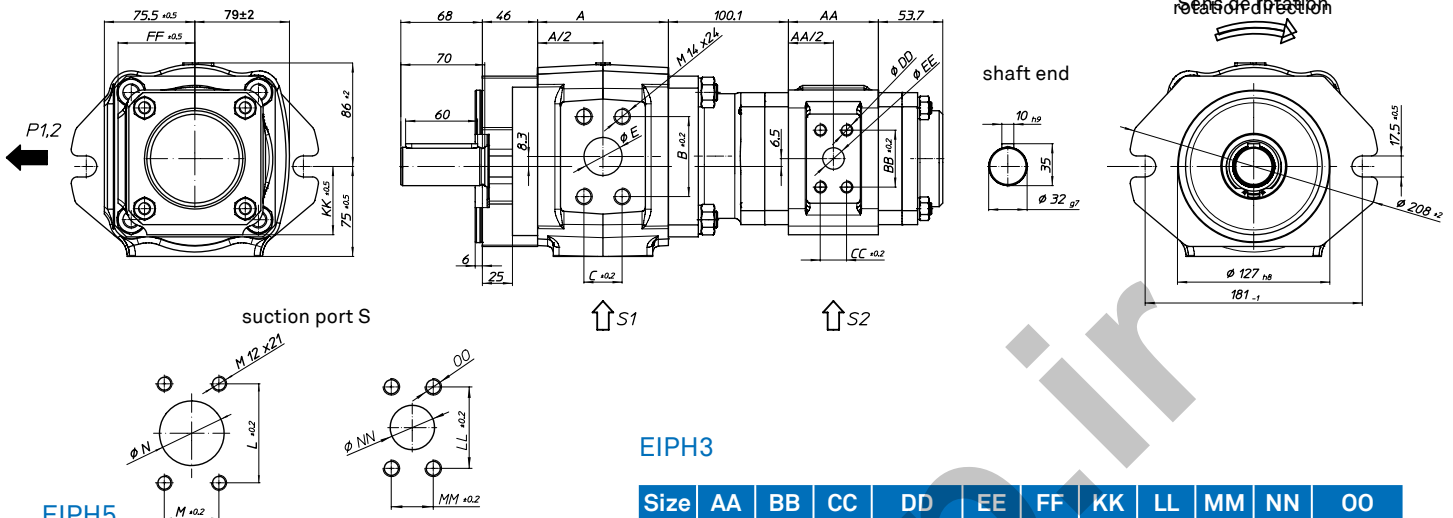

EIPH3

EIPH5

Size	A	B	C	D	E	L	M	N
040	61	57,2	27,8	M12x24	25,4	77,8	42,9	51
050	69	57,2	27,8	M12x24	25,4	77,8	42,9	51
064	81	57,2	27,8	M12x24	25,4	77,8	42,9	51
080	93	66,7	31,8	M14x24	31,75	77,8	42,9	51
100	109	66,7	31,8	M14x24	31,75	88,9	50,8	63,5

Size	AA	BB	CC	DD	EE	FF	KK	LL	MM	NN	OO
014	51	38,1	17,5	M8x15	14	64	57	52,4	26,2	25	M10x17
016	53	38,1	17,5	M8x15	14	64	57	52,4	26,2	25	M10x17
020	58,5	47,5	22	M10x17	18	64	57	58,7	30,2	32	M10x17
025	65	47,5	22	M10x17	18	64	57	58,7	30,2	32	M10x17
032	75	47,5	22	M10x17	18	64	57	58,7	30,2	32	M10x17
040	86	52,4	26,2	M10x17	20	70	63	58,7	30,2	32	M10x20
050	100	52,4	26,2	M10x17	20	70	63	58,7	30,2	32	M10x20

Double pump with SAE-C2-bolt flange and splined shaft

Order example: EIPH5-___SL23-1X+
EIPH3-___RP36-1X

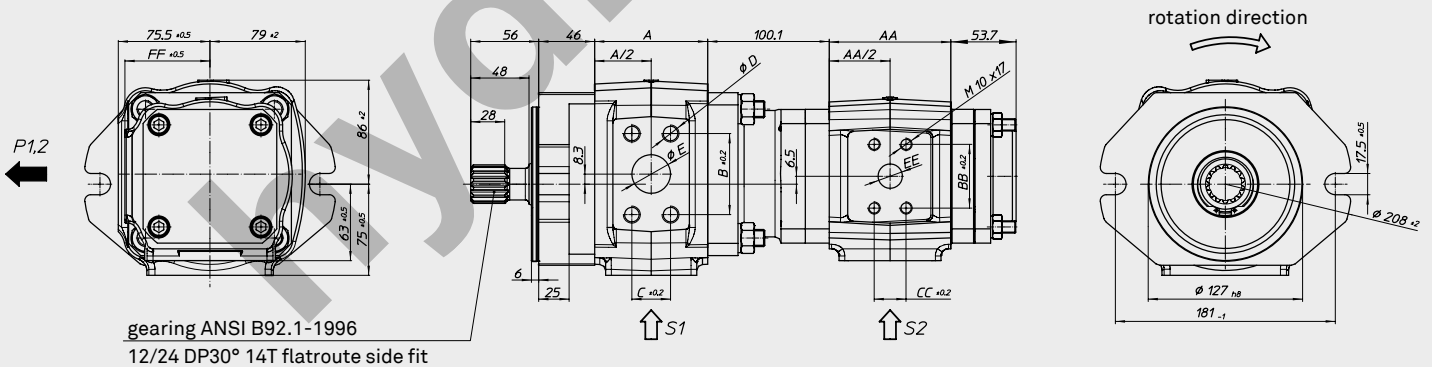

EIPH5

NG	A	B*	C*	D	E	L**	M**	N
040	61	57,2	27,8	M12x24	25,4	77,8	42,9	51
050	69	57,2	27,8	M12x24	25,4	77,8	42,9	51
064	81	57,2	27,8	M12x24	25,4	77,8	42,9	51
080	93	66,7	31,8	M14x24	31,8	77,8	42,9	51
100	109	66,7	31,8	M14x24	31,8	88,9	50,8	63,5

EIPH3

NG	AA	BB	CC	EE	FF	LL	MM	NN
025	65	47,5	22	18	64	69,9	35,7	40
032	75	47,5	22	18	64	69,9	35,7	40
040	86	52,4	26,2	20	70	77,8	42,9	51
050	100	52,4	26,2	20	70	77,8	42,9	51
063	118	52,4	26,2	25,4	70	77,8	42,9	51

* Pressure port: SAE J518, high pressure series (code 62)
** Suction port: SAE J518, standard pressure series (code 61)

The single pumps of a multiple pump assembly are internally connected, even if you connect to the pump inlet. It is therefore no operating with different fluids possible.

Double pump with SAE-C2-bolt flange and straight keyed shaft

Order example: EIPH5-___TK23-1X+
EIPH2-___RP33-1X

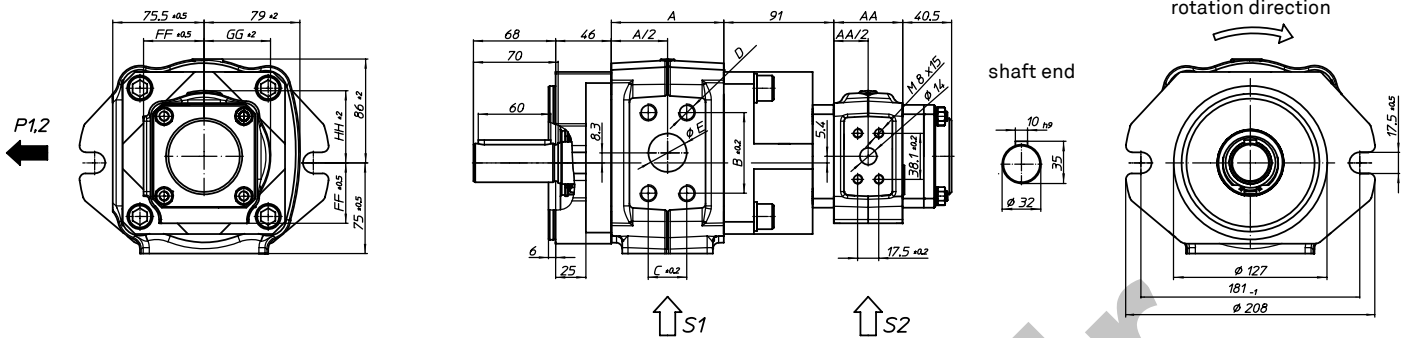

Double pump with SAE-C2-bolt flange and splined shaft

Order example: EIPH5-___TL23-1X+
EIPH2-___RP33-1X

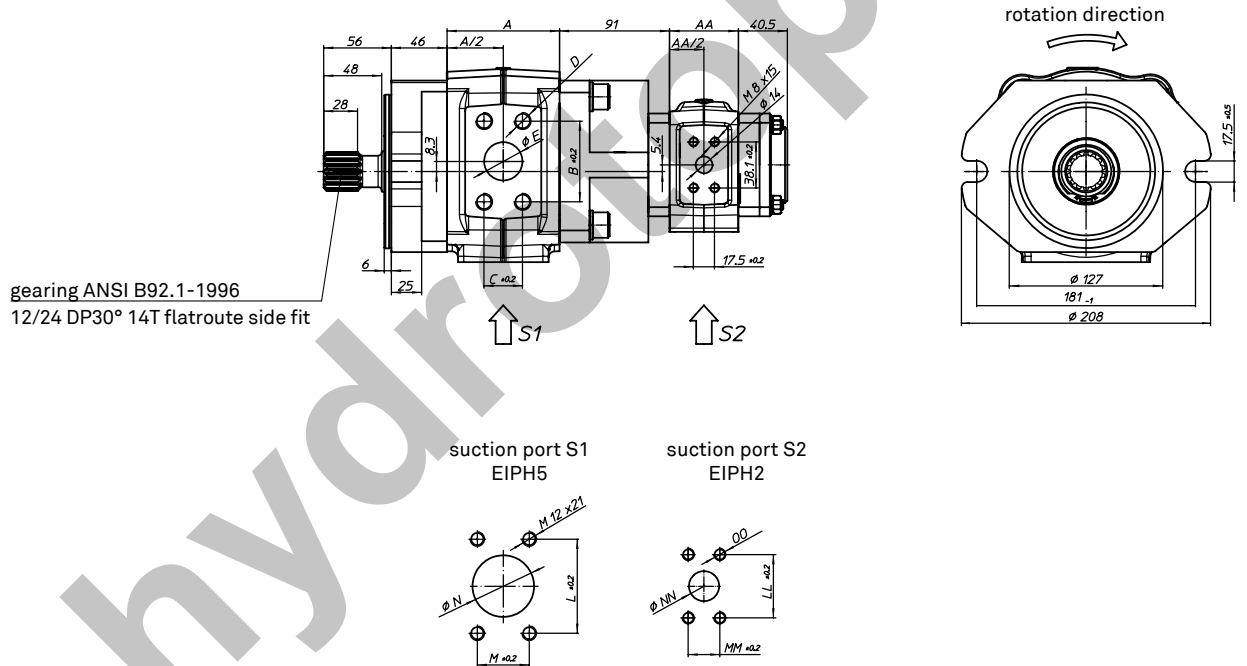

EIPH5

Size	A	B*	C*	D	E	L**	M**	N
040	61	57,2	27,8	M12x24	25,4	77,8	42,9	51
050	69	57,2	27,8	M12x24	25,4	77,8	42,9	51
064	81	57,2	27,8	M12x24	25,4	77,8	42,9	51
080	93	66,7	31,8	M14x24	31,8	77,8	42,9	51
100	109	66,7	31,8	M14x24	31,8	88,9	50,8	63,5

* Pressure port: SAE J518, high pressure series (code 62)

** Suction port: SAE J518, standard pressure series (code 61)

EIPH2

Size	AA	FF	GG	HH	LL	MM	NN	OO
004	36	50	55	59	38,1	17,5	14	M8x15
005	36	50	55	59	38,1	17,5	14	M8x15
006	38	50	55	59	47,5	22	19	M10x16
008	41	50	55	59	47,5	22	19	M10x17
011	47	50	50	59	52,4	26,2	25	M10x17
013	52	50	55	60	52,4	26,2	25	M10x17
016	57	50	55	60	52,4	26,2	25	M10x17
019	64	55	61	65	52,4	26,2	25	M10x17
022	70	55	61	65	52,4	26,2	25	M10x17
025	76	55	61	65	52,4	26,2	25	M10x17

The single pumps of a multiple pump assembly are internally connected, even if you connect to the pump inlet. It is therefore no operating with different fluids possible.

Rated size 019, 022, 025 also available with oversized suction port.

Pump with SAE-D2-bolt flange and straight keyed shaft

Order example: EIPH6-___RK23-1X

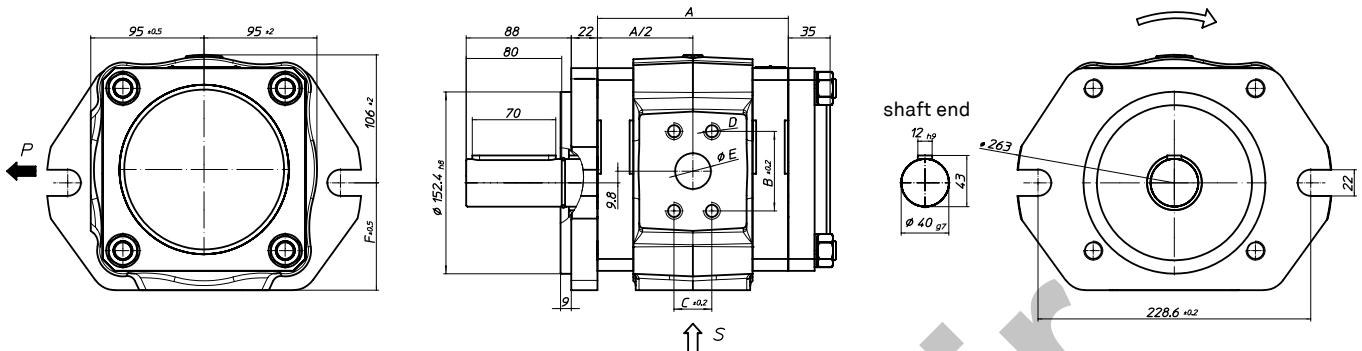

Size	A	B*	C*	D	E	F	L	M	N	O
040	123	57,2	27,8	M12x22	20	90	69,9	35,7	35	M12x25
050	129	57,2	27,8	M12x22	20	90	69,9	35,7	40	M12x25
064	138	57,2	27,8	M12x22	20	90	69,9	35,7	40	M12x25
080	147	66,7	31,8	M14x25	30	90	77,8	42,9	50	M12x25
100	160	66,7	31,8	M14x25	30	90	77,8	42,9	50	M12x25
125	175	66,7	31,8	M14x25	30	90	77,8	42,9	50	M12x25
160	196	66,7	31,8	M14x25	30	90	88,9	50,8	65	M12x25
200	221	79,4	36,5	M16x25	38	92	106,4	61,9	76	M16x25
250	251	79,4	36,5	M16x25	38	92	106,4	61,9	76	M16x25

* Pressure port: SAE 518C, high pressure series (code 62)

Double pump with SAE-D2-bolt flange and straight keyed shaft

Order example: EIPH6-___RK20-1X+
EIPH6-___RP30-1X

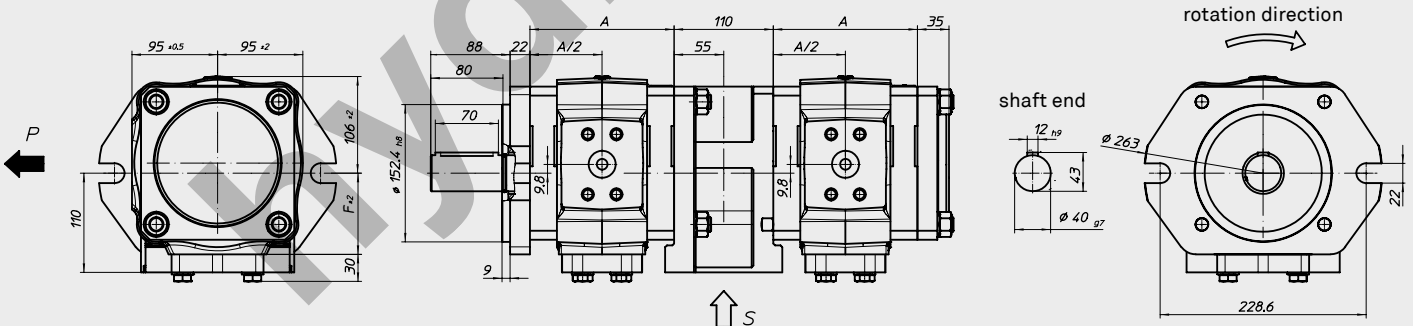

Size	A	F
040	123	90
050	129	90
064	138	90
080	147	90
100	160	90
125	175	90
160	196	90
200	221	92
250	251	92

Above size 160 no common inlet possible

Pressure connections see single pumps
For separate suction, see suction connections single pumps.

suction port

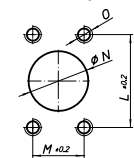

common suction port

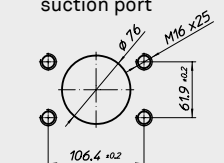

Double pump with SAE-D2-bolt flange and straight keyed shaft

Order example: EIPH6-___RK23-1X+
EIPH2-___RP30-1X

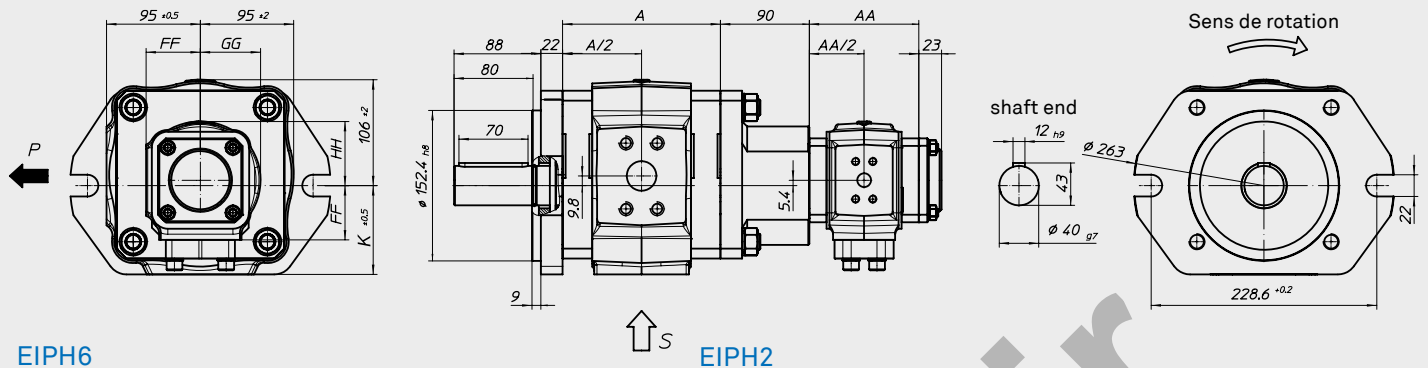

EIPH6

EIPH2

NG	A	F	L	M	N	O
040	123	90	69,9	35,7	35	M12x25
050	129	90	69,9	35,7	40	M12x25
064	138	90	69,9	35,7	40	M12x25
080	147	90	77,8	42,9	50	M12x25
100	160	90	77,8	42,9	50	M12x25
125	175	90	77,8	42,9	50	M12x25
160	196	90	88,9	50,8	65	M12x25
200	221	92	106,4	61,9	76	M16x25
250	251	92	106,4	61,9	76	M16x25

NG	AA	FF	GG	HH
004	71	50	55	59
005	71	50	55	59
006	73	50	55	59
008	76	50	55	59
011	82	50	55	59
013	87	50	55	60
016	92	50	55	60
019	99	55	61	65
022	105	55	61	65
025	111	55	61	65

Pressure connections see single pumps

Double pump with SAE-D2-bolt flange and straight keyed shaft

Order example: EIPH6-___RK20-1X+
EIPH3-___RP30-1X

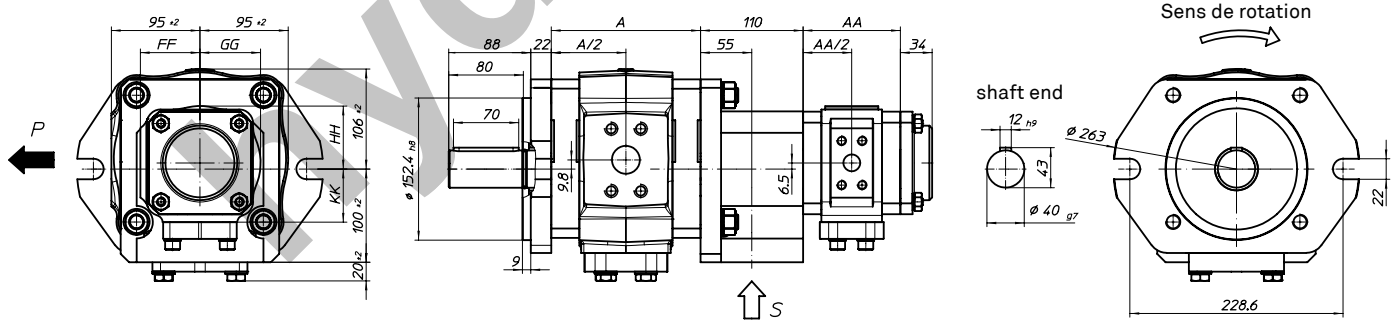

EIPH6

EIPH3

Size	A
040	123
050	129
064	138
080	147
100	160
125	175
160	196
200	221
250	251

Size	AA	FF	GG	HH	KK
014	90,4	64	65	67	57
016	92,4	64	65	67	57
020	97,9	64	65	67	57
025	104,4	64	65	67	57
032	114,4	64	65	67	57
040	125,4	70	73	79	63
050	139,4	70	73	79	63

Pressure connections see single pumps | Above size 160 no common inlet possible
For separate suction, see suction connections single pumps.

SAE flange metric tapped

Version a

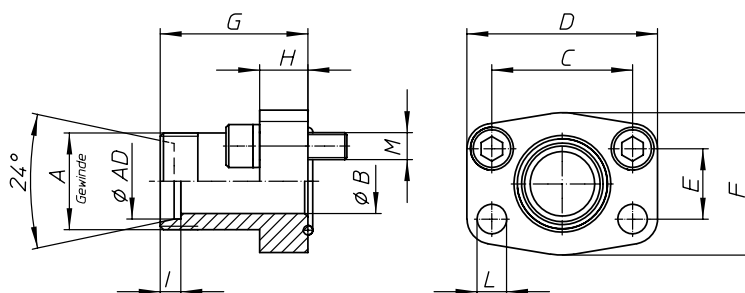

SAE pipe threaded flange

Version b

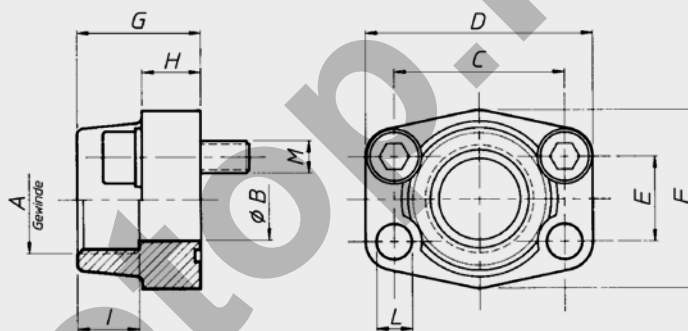

Nr.	Article number	Type	pmax	AD	A	B	C	D	E	F	G	G1	H	I	L	M
1a	07 07 04 0030	GV-AD15-SAE12-C	315	15	M22x1,5	12	38,1	54	17,5	46	52		13	7	9	M8x25
1b	07 07 04 0026	EFG1/2-SAE12-C	350		G1/2"	13	38,1	54	17,5	46		36	19	19	9	M8x30
2a	07 07 04 0031	GV-AD22-SAE34-C	160	22	M30x2	19	47,6	65	22,2	50	60		14	7,5	11,5	M10x30
2b	07 07 04 0027	EFG3/4-SAE34-C	350		G3/4"	19	47,6	65	22,2	50		36	18	19	11	M10x35
3a	07 07 04 0032	GV-AD28-SAE100-C	160	28	M36x2	24	52,4	70	26,2	55	63		16	7,5	11,5	M10x30
3b	07 07 04 0028	EFG1-SAE100-C	315		G1"	25	52,4	70	26,2	55		38	18	22	11	M10x35
4a	07 07 04 0033	GV-AD35-SAE114-C	160	35	M45x2	29	58,7	79	30,2	68	65		14	10,5	11,5	M10x30
4b	07 07 04 0029	EFG1 1/4-SAE114-C	250		G1 1/4"	32	58,7	79	30,2	68		41	21	22	11,5	M10x40
5a	07 07 04 0037	GV-AD42-SAE112-C	160	42	M52x2	36	69,9	94	35,7	78	70		16	11	13,5	M12x35
5b	07 07 04 0034	EFG1 1/2-SAE112-C	200		G1 1/2"	38	69,9	94	35,7	78		45	25	24	13,5	M12x45
6b	07 07 04 0036	EFG2-SAE200-C	200		G2"	51	77,8	102	42,9	90		45	25	30	13,5	M12x45
7b	07 07 04 0041	EFG2 1/2-SAE212-C	160		G2 1/2"	63	88,9	114	50,8	105		30	25	30	13,5	M12x45
8a	07 07 04 0042	GV-AD30-SAE100-HD	400	30	M42x2	25	57,2	81	27,8	70	82		24	13,5	13	M12x45
9a	07 07 04 0043	GV-AD38-SAE114-HD	400	38	M52x2	29	66,6	95	31,8	78	92		27	16	15	M14x50
10b	07 07 04 0050	EFG3-SAE300-C	160		G3"	73	106,4	134	61,9	116		50	27	38	17,5	M16x50

Summary of SAE Pressure- and Suction flange SAE J 518C, ISO 6162

Type	Inlet	No.	Version		Outlet	No.	Version	
			a	b			a	b
EIPH2-004-005	1/2"	1	•	•	1/2"	1	•	•
EIPH2-006-008	3/4"	2	•	•	1/2"	1	•	•
EIPH2-011-025	1"	3	•	•	1/2"	1	•	•
EIPH2-019-025	1 1/2"	5	•	•	1/2"	1	•	• 1)
EIPH3-014-016	1"	3	•	•	1/2"	1	•	•
EIPH3-020-032	1 1/4"	4	•	•	3/4"	2	•	•
EIPH3-040-064	1 1/4"	4	•	•	1"	3	•	•
EIPH3-025-032	1 1/2"	5	•	•	3/4"	2	•	• 1)
EIPH3-040-050	2"	6	•	•	1"	3	•	• 1)
EIPH5-064	2"	6	•	•	1"*	8	•	•
EIPH5-080	2"	6	•	•	1 1/4" *	9	•	•
EIPH5-100	2 1/2"	7	•	•	1 1/4" *	9	•	•
EIPH6-040-064	1 1/2"	5	•	•	1" *	8	•	•
EIPH6-080-125	2"	6	•	•	1 1/4" *	9	•	•
*EIPH6-160 <small>High pressure range</small>	2 1/2"	7	•	•	1 1/4" *	9	•	•
EIPH6-200-250	3"	10	•	•	1 1/2" *	9	◦	◦

Suction flange for Intermediate housing

Type	Inlet	No.	Version	
			a	b
EIPH2/2 up to size 016	1"	3	•	•
EIPH2/2 from size 019	1 1/4"	4	•	•
EIPH3/2	1 1/2"		•	•
EIPH3/3 up to size 032	1 1/2"	5	•	•
EIPH3/3 from size 040	2"	6	•	•
EIPH6/6	3"		◦	◦
EIPH6/3	3"		◦	◦

• = available ◦ = on request

hydrotob.ir

hydrotob.ir

hydrotop.ir

EIP H2 - 016 RK03 - 1X SXXX

Special version number

Tailor made design - No standard

Revision code

1st number: Change of external dimensions

2nd number: Internal modifications

Intake and outlet connection - with metric threads

3: According to SAE J 518 - Code 61 / 62

6: According to SAE J 518 - Code 61 / 62 with oversized suction port for variable speed drives

0: suction port closed; common inlet

- other flanges on request -

Mounting flange

0: SAE/A 2-bolt flange, centring collar Ø 82,55 at EIPH2

2: SAE/B 2-bolt flange, centring collar Ø 101,6 at EIPH2/3

2: SAE/C 2-bolt flange, centring collar Ø 127,0 at EIPH5

2: SAE/D 2-bolt flange, centring collar Ø 152,4 at EIPH6

3: Direct mounting

5: VDMA flange on request

- other flanges on request

Shaft end

A: straight keyed shaft

K: straight keyed shaft with PTO

B: SAE splined shaft end

L: SAE splined shaft end with PTO

P: SAE splined shaft end on both sides*

Rotation direction

R: Clockwise (S: CW size 5/3 I T: CW size 5/2)

L: counterclockwise

Rated size

Three digits

Frame size

2, 3, 5 or 6

Type

H: High pressure pump

Eckerle internal gear pump

*Secondary pump section - not usable as single pump

Order example
EIPH2-016RK03-1X

High pressure pump, frame size 2 with 15,8 cm³/rev, clockwise rotation, straight keyed shaft with PTO, SAE/B2-bolt flange connection, SAE type suction and pressure port, revision code 1X

Variable-speed operation

As a matter of principle, Eckerle internal gear pumps are eminently suited for variable speed operation. Even at low viscosities and high temperatures of the pumping medium, the pumps run extremely energy efficiently and highly dynamically over a wide speed range due to the radial and axial gap compensation.

However, with variable speed operation certain boundary conditions should be observed. The exemplary cycle shown below illustrates this clearly.

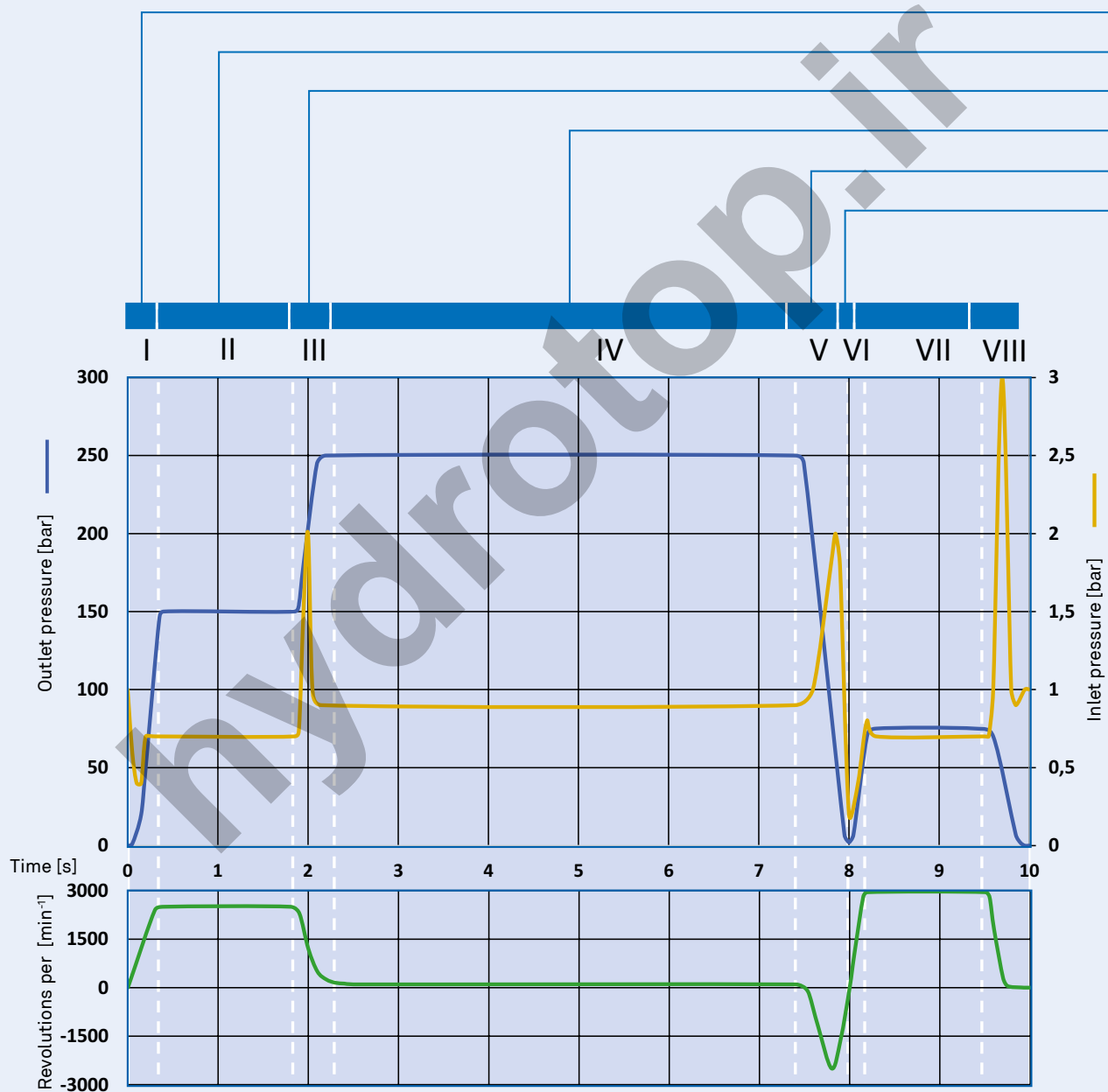

I. Start:

Eckerle internal gear pumps are able to build up pressure from standstill. This happens smoothly when the pump starts from an unpressurized state. Please talk to Eckerle, if due to the system design the pump is pressurized at standstill.

II. + VII. Pump operation:

Eckerle internal gear pumps are capable of providing a speed-dependent volumetric flow at any pressure level during pump operation. However, application limits of the respective sizes must be observed.²⁾

III. + VIII. Deceleration:

With Eckerle internal gear pumps very high decelerations can be achieved. It must be ensured though that line-dependent pressure peaks can develop within the suction side. These should not exceed the maximum permissible inlet pressure.^{2) 3)}

IV. Pressure Holding Operation:

Eckerle internal gear pumps are able to build up high pressures even at very low speeds due to the gap compensation. Hold pressure operation is thus extremely energy-efficient. Pump operation should follow after the hold pressure operation to flush out the pump.

V. Reverse operation:

Eckerle internal gear pumps are usually able to run highly dynamically in the opposite direction of rotation in order to lower pressure peaks, or by means of a hydraulic motor. However, it must be ensured that the output pressure is always higher than the input pressure.^{1) 3)}

VI. Acceleration:

With Eckerle internal gear pumps very large speed-ups can be run. These are limited by inlet pressure, geometry of the suction line and viscosity. However, these may not drop below the specified minimum inlet pressure of the series.^{1) 3)}

1) See Characteristics

2) See Technical data

3) To avoid critical operating points, we recommend taking measurements of the pump's inlet and outlet pressure near the pump with a scanning rate of at least 1 kHz when a new pump cycle starts.

Volume flow

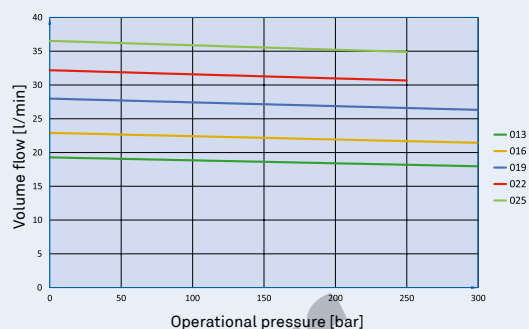
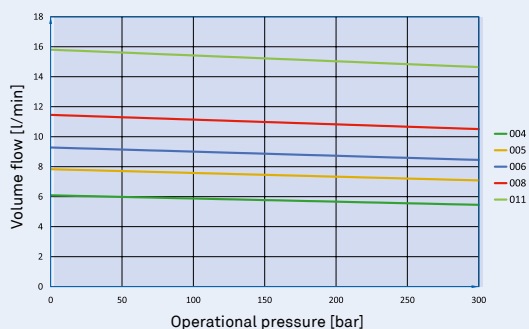

Level of efficiency

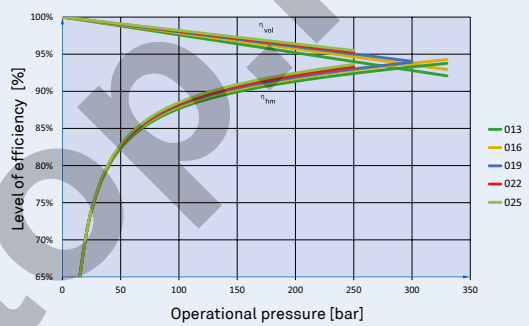
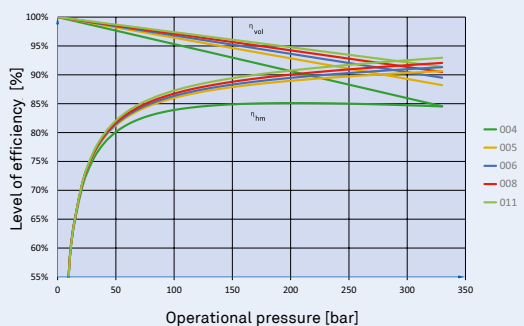

Driving power

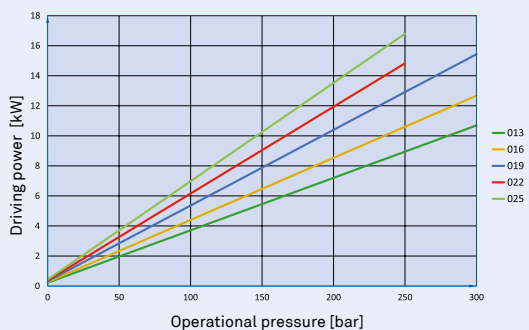
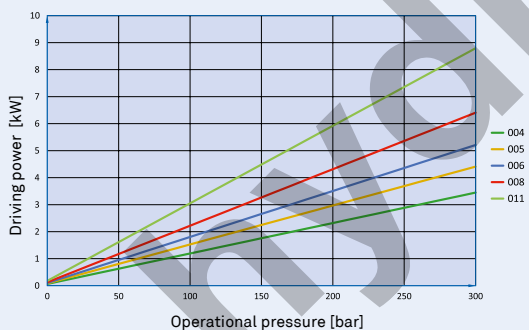

Sound level pressure in air

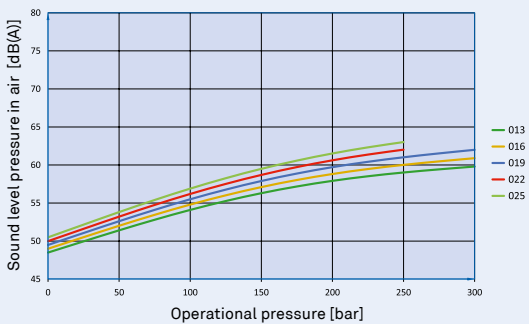
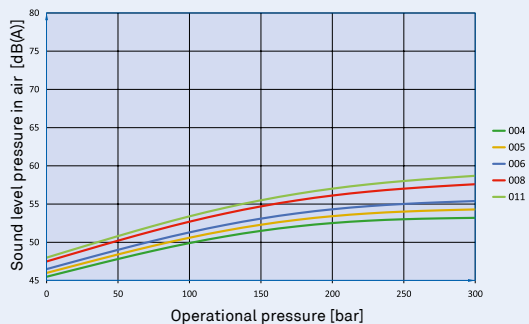

Measurement conditions: Speed 1450 min⁻¹, viscosity 46 mm²/s, operating temperature 40°C
 Measured in silent room in accordance with DIN 45 635 sheet 26, microphone distance: 1 m axial

Volume flow

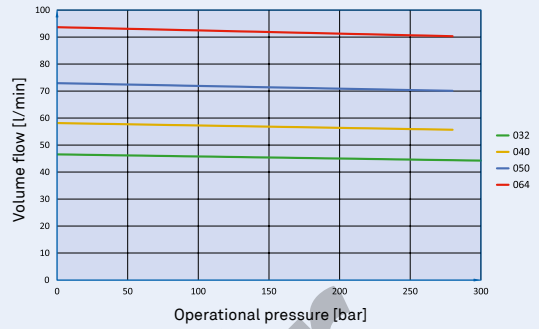
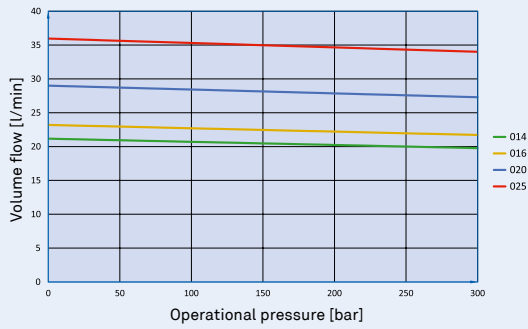

Level of efficiency

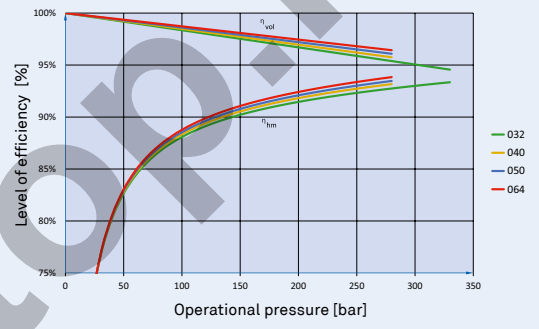
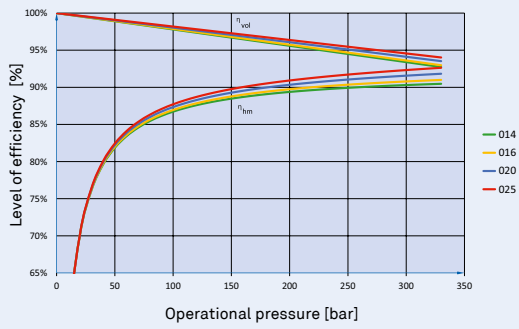

Driving power

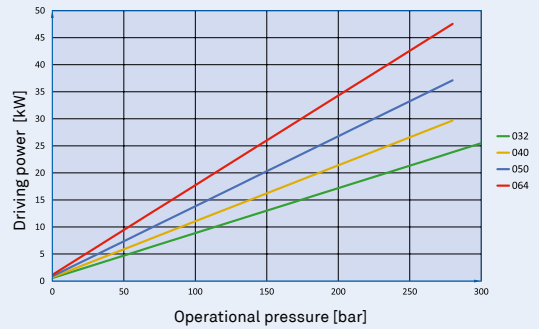
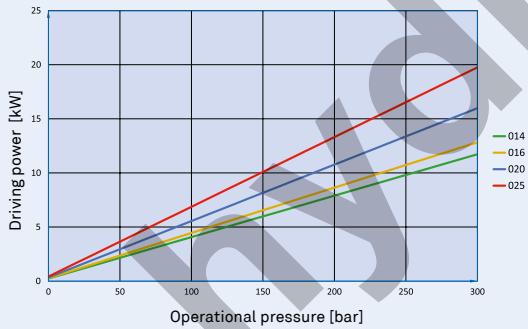

Sound level pressure in air

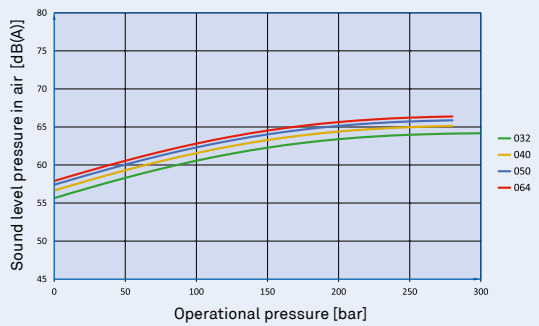
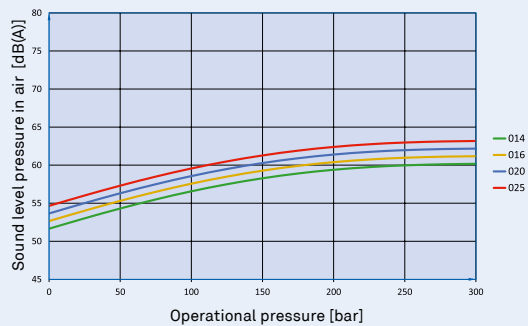

Measurement conditions: Speed 1450 min⁻¹, viscosity 46 mm²/s, operating temperature 40°C
 Measured in silent room in accordance with DIN 45 635 sheet 26, microphone distance: 1 m axial

Volume flow

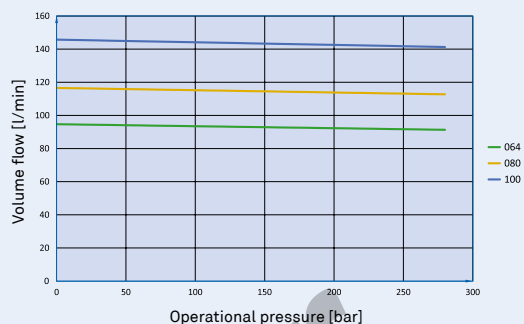

Level of efficiency

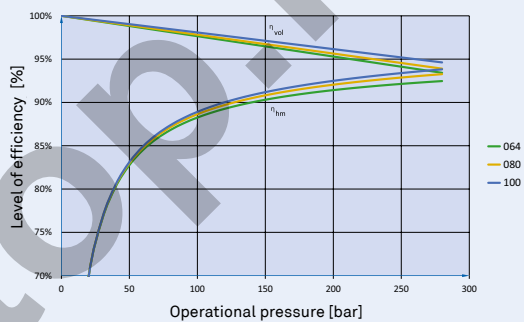

Driving power

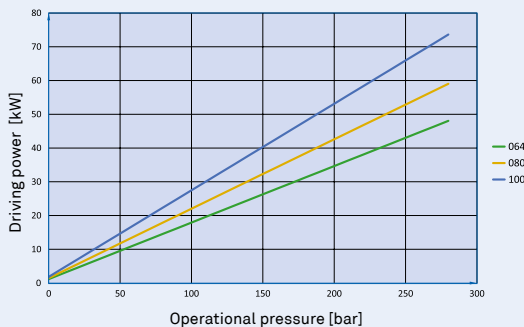

Sound level pressure in air

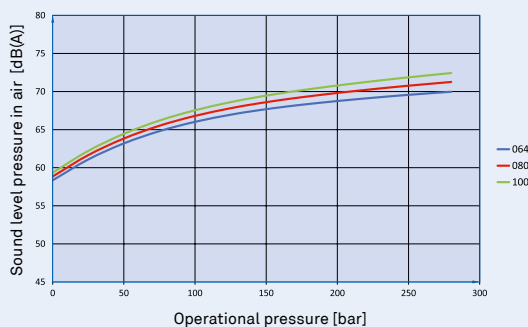

Measurement conditions: Speed 1450 min⁻¹, viscosity 46 mm²/s, operating temperature 40°C
 Measured in silent room in accordance with DIN 45 635 sheet 26, microphone distance: 1 m axial

Volume flow

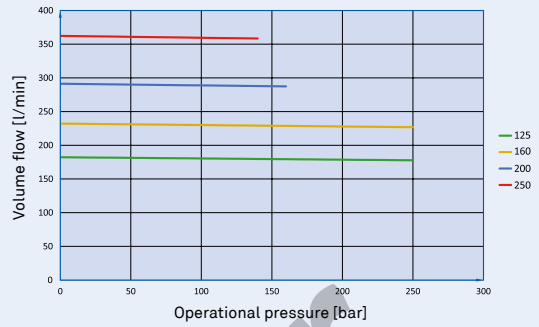
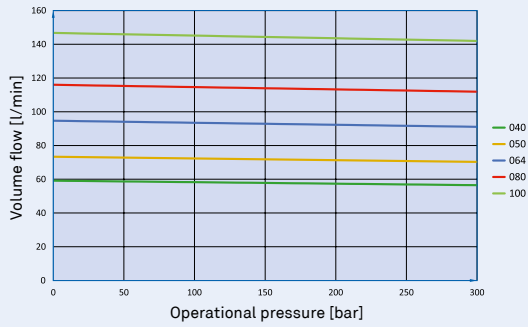

Level of efficiency

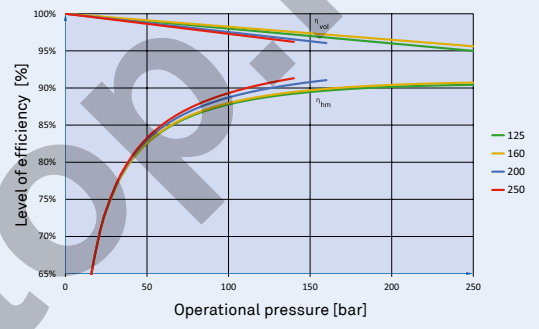
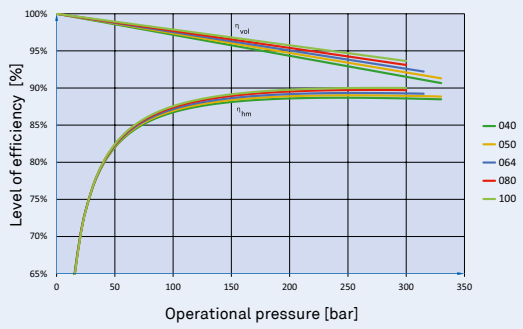

Driving power

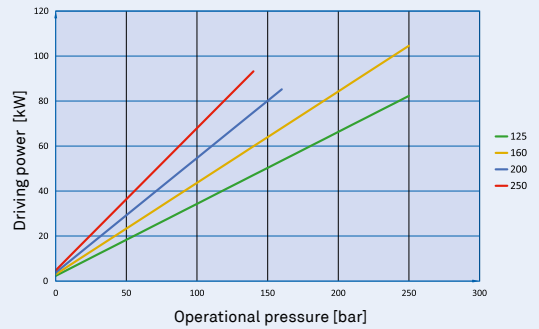
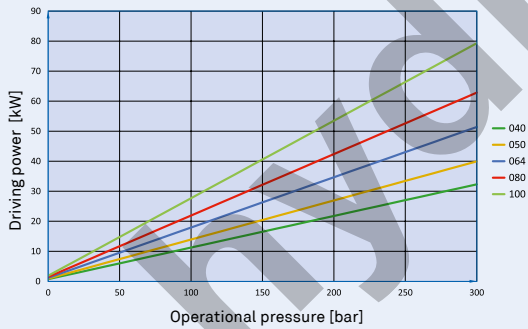

Sound level pressure in air

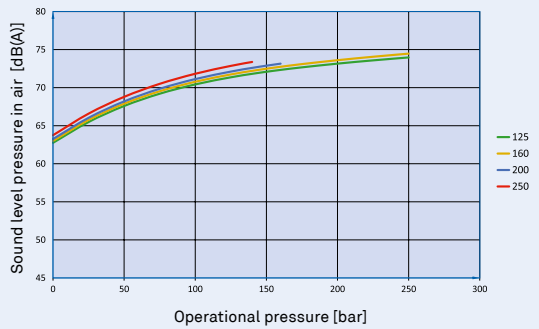
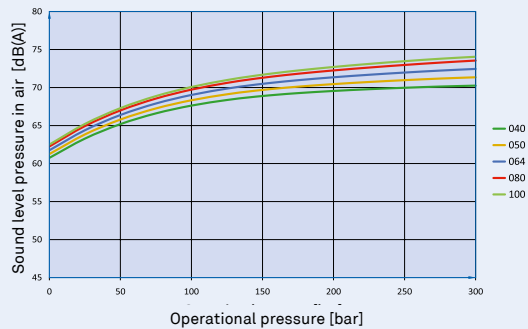

Measurement conditions: Speed 1450 min⁻¹, viscosity 46 mm²/s, operating temperature 40°C
 Measured in silent room in accordance with DIN 45 635 sheet 26, microphone distance: 1 m axial

Characteristics

Permissible peak operational pressure dependent on speed

EIPH2

Nominal size 019, 022 & 025 including suction port 1½"

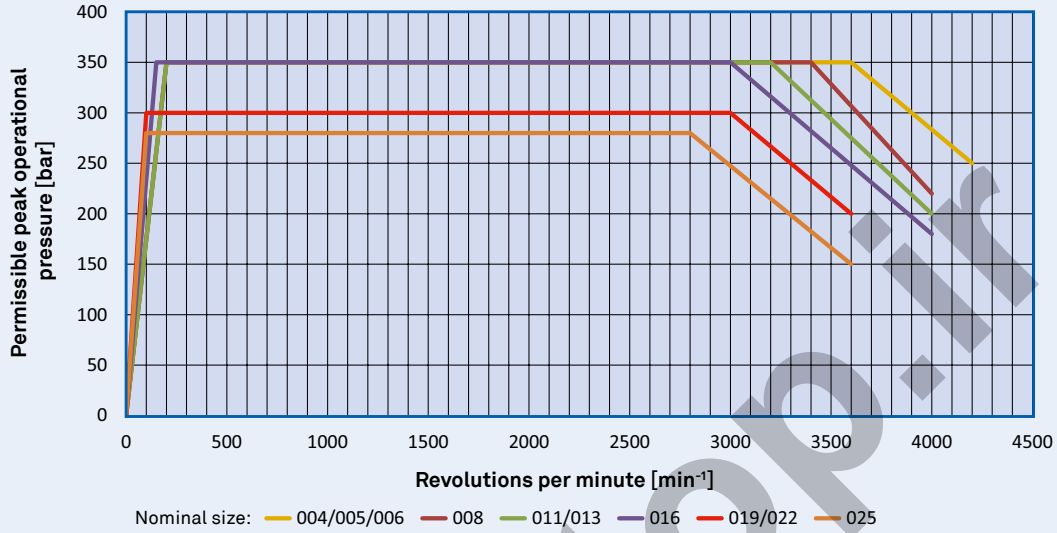

EIPH3

Nominal size 040, 050 & 064 including suction port 2"

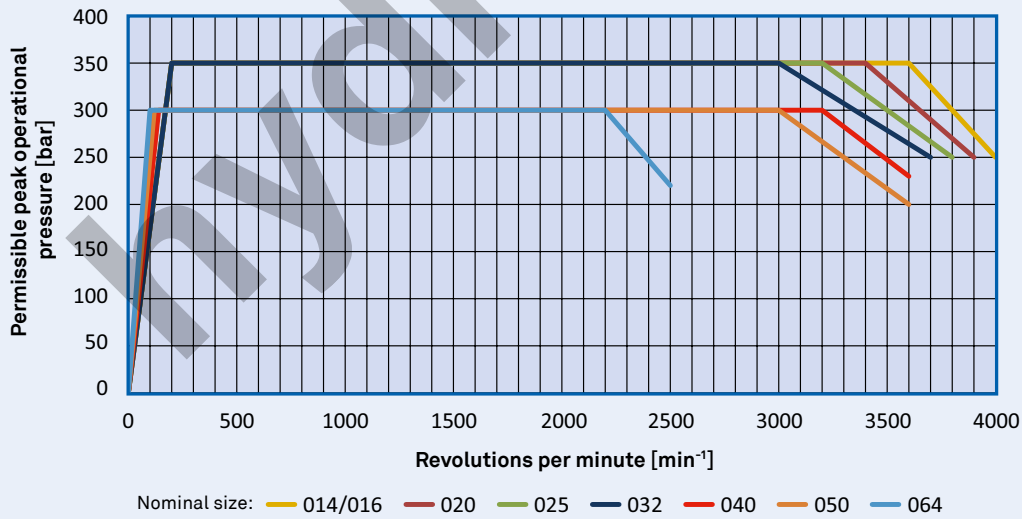

Peak operating pressures are permitted for a maximum of 10 seconds or 15% of the duty cycle

EIPH5

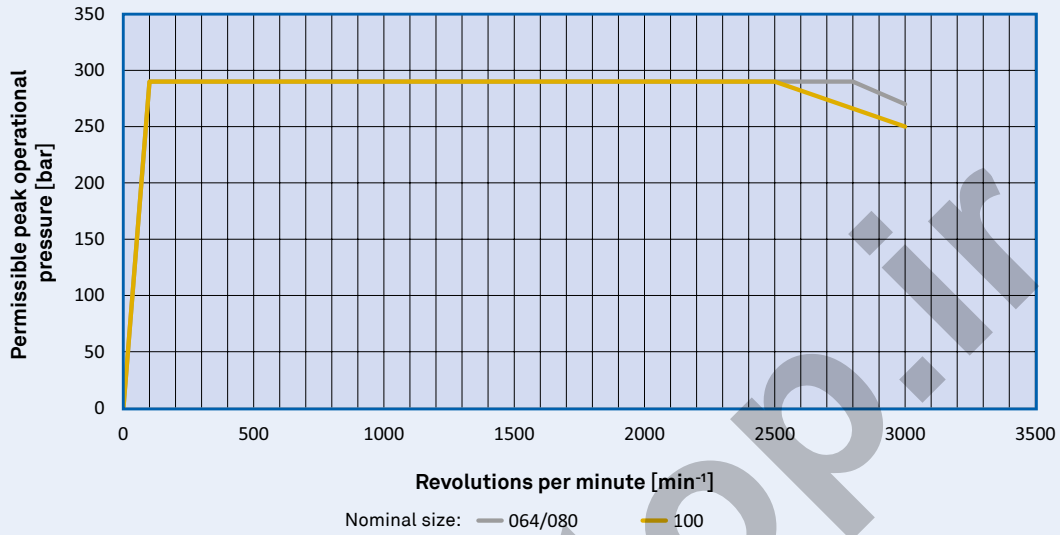

EIPH6

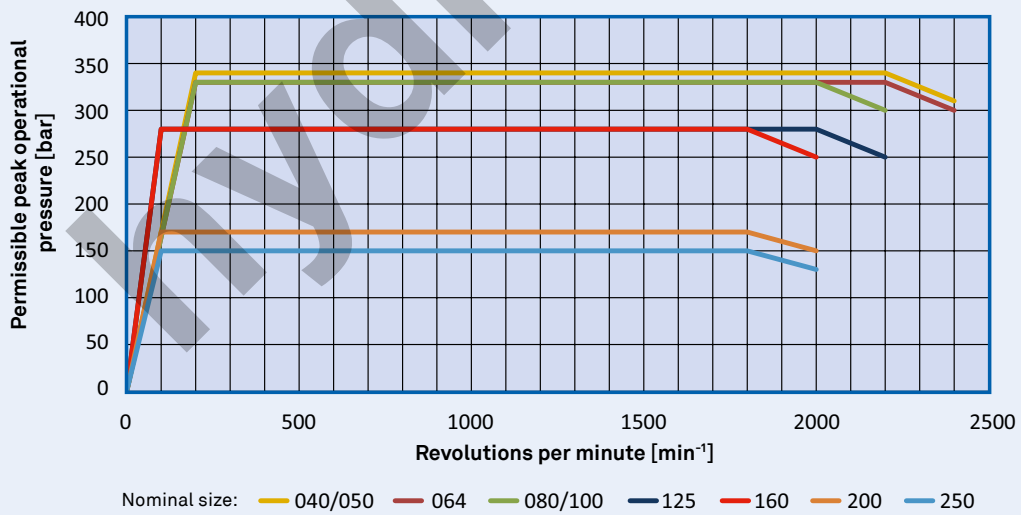



For further information please visit:
eckerle.com

All indicated data serve alone the product description and are not as characteristics in the legal sense to be understood. Subject to alterations.

hydrotop.ir

Eckerle Technologies GmbH
P.O. box 1368
Otto-Eckerle-Straße 6/12A
76316 Malsch, Germany
Tel. +49 (0) 7246 9204-0
sales.EHD@eckerle.com

eckerle