

EIPS1
EIPS2

Internal gear pumps

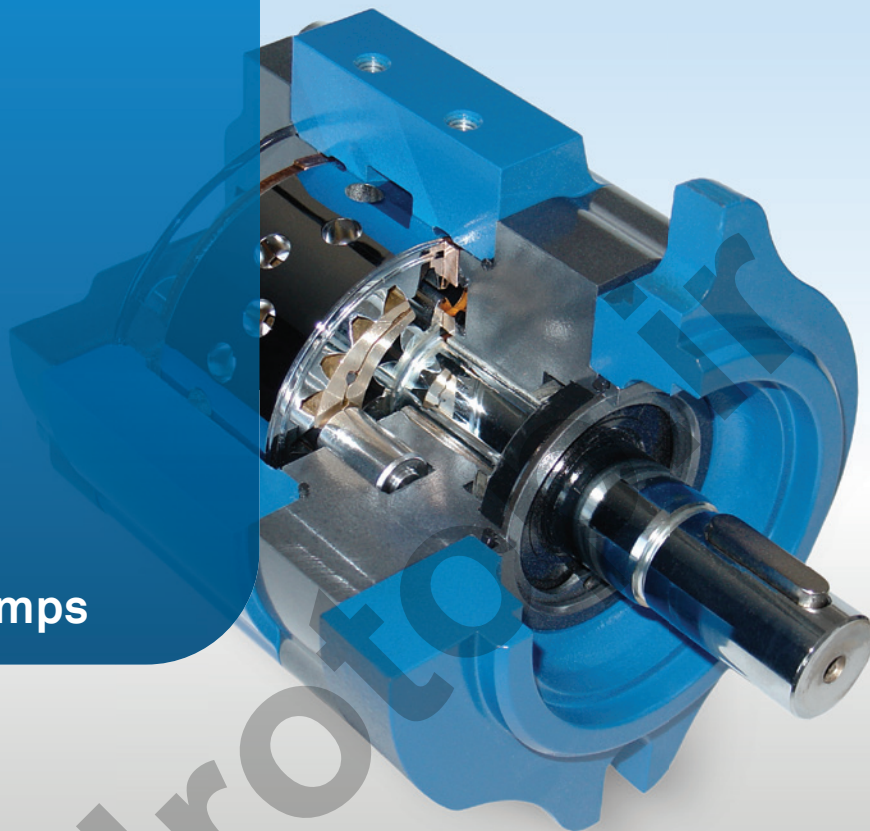

Internal gear pump Type EIPS1

EIPS1

Characteristics

- Internal gear pump with axial and radial gap compensation
- Radial compensation with segments
- Field of application:
Mobile hydraulic systems, e.g. for fork lifts, light industrial hydraulic applications
- Direct mounting and SAE flange
- Low noise
- Long time life
- Low pulsation (pressure pulsation ~ 2%)

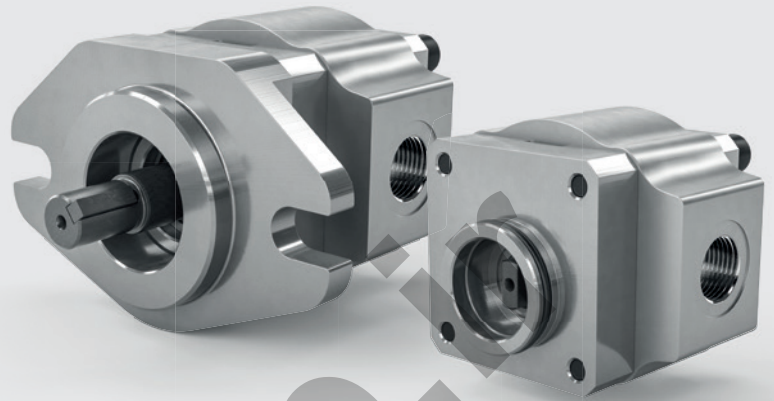

Technical Data

Rated Size	016	020	025	032	040	050
Spec. volume Vth [cm ³ /rev]*	1,6	2,0	2,6	3,2	4,0	5,0
Continuous operating pressure [bar]**			300		250	210
Peak operating pressure [bar] max. 10 sec. 15 % duty cycle			320		280	220
Cut-in pressure peak 100 ms [bar]**			350		300	250
Max. speed [min ⁻¹]				4.000		
Nominal speed [min ⁻¹]				400 – 3.600		
Operating viscosity [mm ² /s]				10 – 300		
Starting viscosity [mm ² /s]				2.000		
Operating temperature [°C]				-20 to +100		
Operating medium				HL – HLP DIN 51 524 Part 1/2		
Max. medium temperature [°C]				120		
Min. medium temperature [°C]				-40		
Max. ambient temperature [°C]				80		
Min. ambient temperature [°C]				-40		
Max. admission pressure (intake side) [bar]				2 bar absolute		
Min. admission pressure (intake side) [bar]				0,8 bar absolute (start 0,6)		
Degree of filtration				Class 20/18/15 due to ISO 4406		
Life expectancy				not less than 1 x 10 ⁶ against peak operating pressure		

* Due to manufacturing tolerances the displacement volume could vary.

** For acceptable pressure at 400-1,800 rpm. Further rpm on request.

The pumps have no corrosion protection. The max. permissible values must not be applied cumulatively. Please contact us.

Internal gear pump Type EIPS2 with constant displacement volume

EIPS2

Characteristics

- Internal gear pump with axial and radial gap compensation
- Radial compensation with segments
- Field of application:
Mobile hydraulic systems, e.g. for fork lifts, light industrial hydraulic applications
- Direct mounting and SAE flange
- Low noise
- Long time life
- Low pulsation (pressure pulsation ~ 2%)

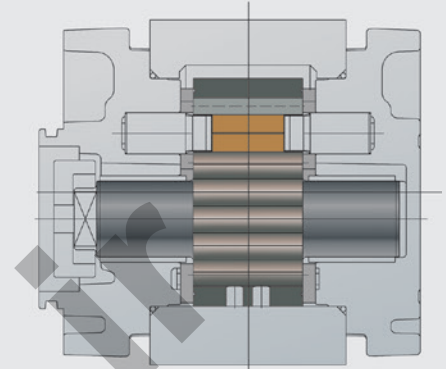
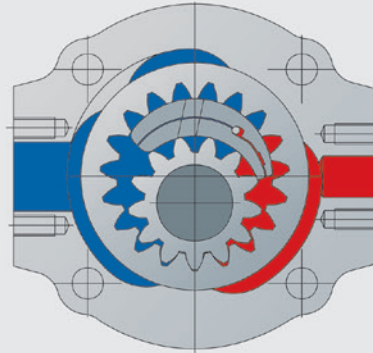

Technical Data:

Rated Size	005	006	008	011	013	016	019	022	025
Spec. volume V_{th} [cm ³ /rev]**	5,4	6,4	7,8	10,8	13,3	15,6	18,9	21,8	24,8
Continuous operating pressure [bar]	250								
Peak operating pressure [bar] max. 10 sec. 15% duty cycle				320			300		280
Cut-in pressure peak 100 ms [bar]				350			325		300
Nominal speed [min ⁻¹]	200 – 4.000			200 – 3.600			100 – 3.000		
Max. speed [min ⁻¹]	4.200			4.000			3.600		
Operating viscosity [mm ² /s]	10 – 300								
Starting viscosity [mm ² /s]	2.000								
Operating temperature [°C]	-20 to +100								
Operating medium	HL – HLP DIN 51 524 part 1/2								
Max. medium temperature [°C]	120								
Min. medium temperature [°C]	-40								
Max. ambient temperature [°C]	80								
Min. ambient temperature [°C]	-40								
Max. admission pressure (intake side) [bar]	2 bar absolute								
Min. admission pressure (intake side) [bar]	0,8 bar absolute (start 0,6)								
Weight appr. [kg]	2,9	3,0	3,1	3,3	3,5	3,6	3,8	4,0	4,2
Degree of filtration	Class 20/18/15 due to ISO 4406								
Life expectancy	not less than 1×10^6 load cycles against peak operating pressure								
Efficiency η_{vol} [%]	91	92	93		94		95		
Efficiency η_{hm} [%]	90		91	92		93			
Pump noise* (measured in sound chamber) dB[A]	55	56	58	59	60	61	62	63	64

$n = 1.450 \text{ min}^{-1}$ $\Delta p = 250 \text{ bar}$ $T = 50 \text{ °C}$ Medium: HLP 46 Bruggen value min. 30N/mm² recommended 50N/mm² for servo applications

* Measured in anechoic room of Eckerle Hydraulic Division; Axial microphone distance 1.0 m

** Due to manufacturing tolerances the displacement volume could vary

The pumps have no corrosion protection. The max. permissible values must not be applied cumulatively. Please contact us.

Pump with oldham coupling

Ordering example: EIPS1-___RD31-1X

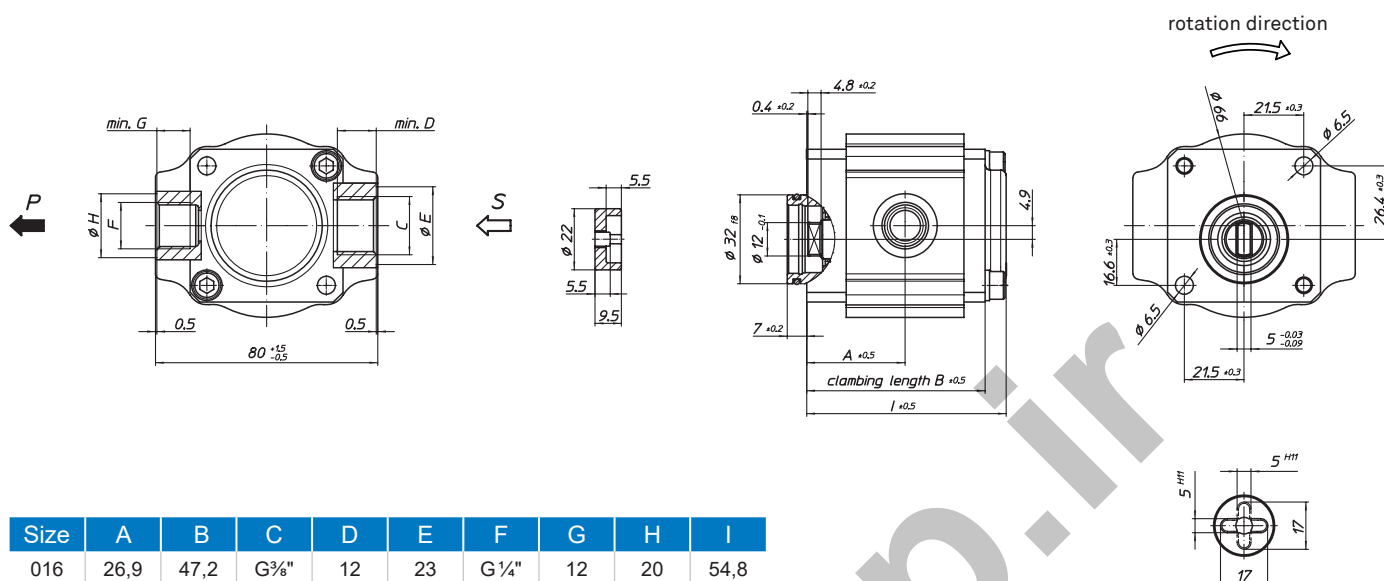

Size	A	B	C	D	E	F	G	H	I
016	26,9	47,2	G $\frac{3}{8}$ "	12	23	G $\frac{1}{4}$ "	12	20	54,8
020	27,9	49,2	G $\frac{3}{8}$ "	12	23	G $\frac{1}{4}$ "	12	20	56,8
025	29,4	52,2	G $\frac{3}{8}$ "	12	23	G $\frac{1}{4}$ "	12	20	59,8
032	30,9	55,2	G $\frac{1}{2}$ "	14	28	G $\frac{3}{8}$ "	12	23	62,8
040	32,9	59,2	G $\frac{1}{2}$ "	14	28	G $\frac{3}{8}$ "	12	23	66,8
050	35,4	64,2	G $\frac{1}{2}$ "	14	28	G $\frac{3}{8}$ "	12	23	71,8

Coupling included in scope of delivery

Pump with SAE/AA-2- bolt flange and straight keyed

Ordering example: EIPS1-___RA01-1X

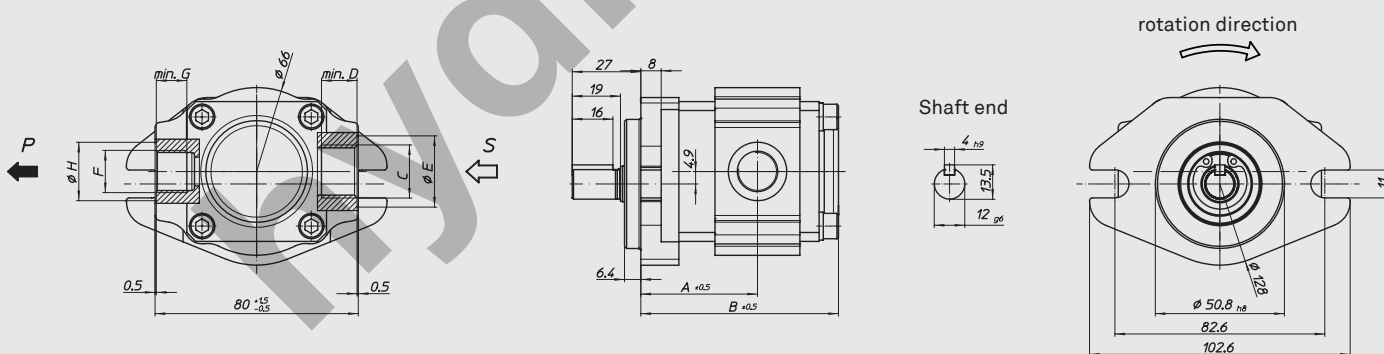

Size	A	B	C	D	E	F	G	H
016	41,9	69,8	G $\frac{3}{8}$ "	12	23	G $\frac{1}{4}$ "	12	20
020	42,9	71,8	G $\frac{3}{8}$ "	12	23	G $\frac{1}{4}$ "	12	20
025	44,4	74,8	G $\frac{3}{8}$ "	12	23	G $\frac{1}{4}$ "	12	20
032	45,9	77,8	G $\frac{1}{2}$ "	14	28	G $\frac{3}{8}$ "	12	23
040	47,9	81,8	G $\frac{1}{2}$ "	14	28	G $\frac{3}{8}$ "	12	23
050	50,4	86,8	G $\frac{1}{2}$ "	14	28	G $\frac{3}{8}$ "	12	23

Pump with tang shaft

Order example: EIPS2 - _ _ _LD34-1X

Size	A	B	C
005	43	82,5	72
006	44	84,5	74
008	45,5	87,5	77
011	48,5	93,5	83
013	51	98,5	88
016	53,5	103,5	93
019	57	110,5	100
022	60	116,5	106
025	63	122,5	112

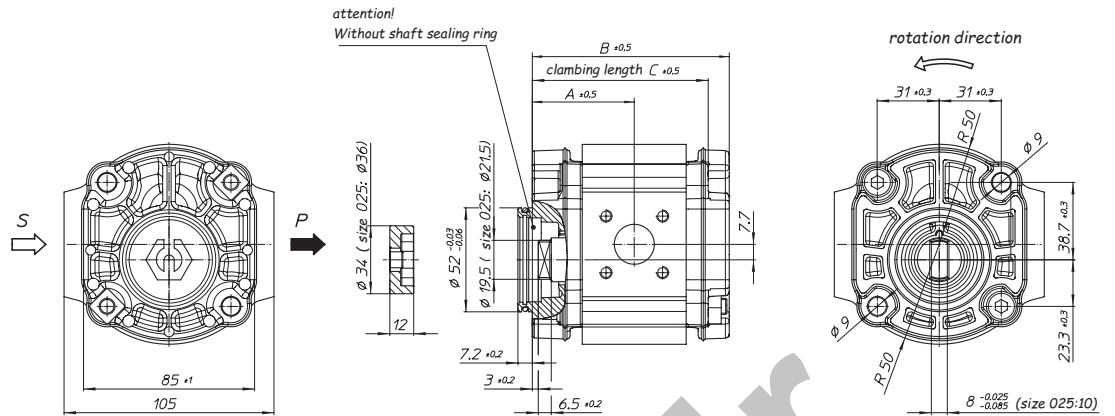

Coupling included in scope of delivery.
Provide M8 DIN 912 fastening screws with DIN 433 plain washer, tightening torque M=25+5 Nm

Pump with SAE-A2-bolt flange and splined shaft

Order example: EIPS2 - _ _ _RB04-1X

Size	A	B	D	E	F
005	62	101,5	16	24	31,5
006	63	103,5	16	24	31,5
008	64,5	106,5	16	24	31,5
011	67,5	112,5	16	24	31,5
013	70	117,5	16	24	31,5
016	72,5	122,5	16	24	31,5
019	76	129,5	16	24	31,5
022	79	135,5	22	33	40,9
025	82	141,5	22	33	40,9

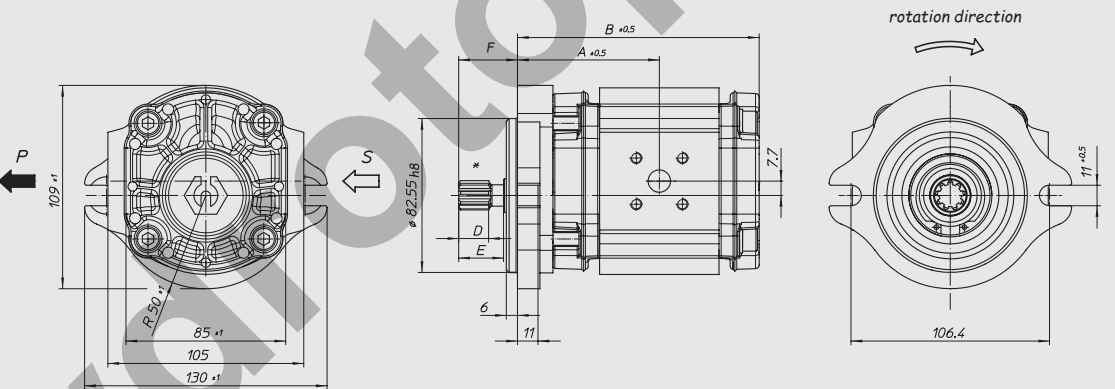

* Size 005-019: spline ANSI B92.1 - 1996
16/32 DP30° x 9T flatroot side fit
Size 022 and 025: spline ANSI B92.1 - 1996
16/32 DP30° x 13T flatroot side fit

Pump with SAE-A2-bolt flange and straight keyed shaft

Order example: EIPS2 - _ _ _RA04-1X S111

Size	A	B
005	62	104,5
006	63	106,5
008	64,5	109,5
011	67,5	115,5
013	70	120,5
016	72,5	125,5
019	76	132,5
022	79	138,5
025	82	144,5

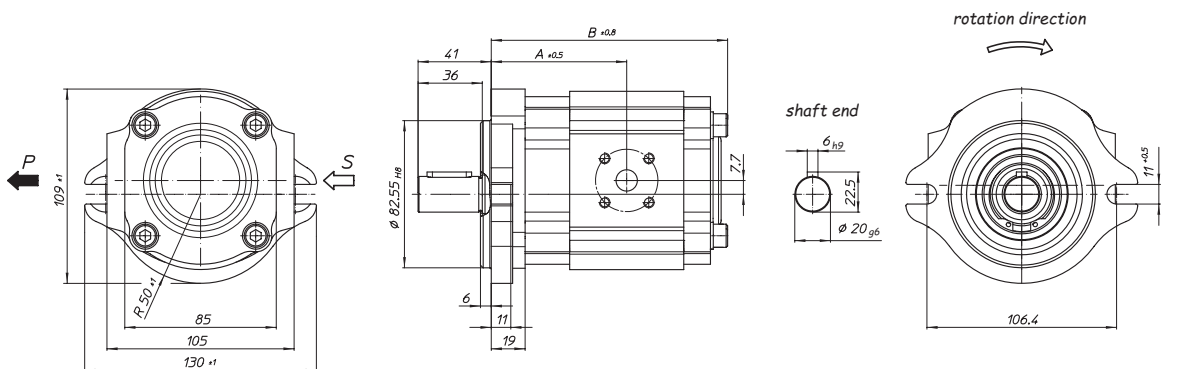

Pump with SAE-A2-bolt flange and straight keyed shaft

Order example: EIPS2 - _ _ _ RA04-1X

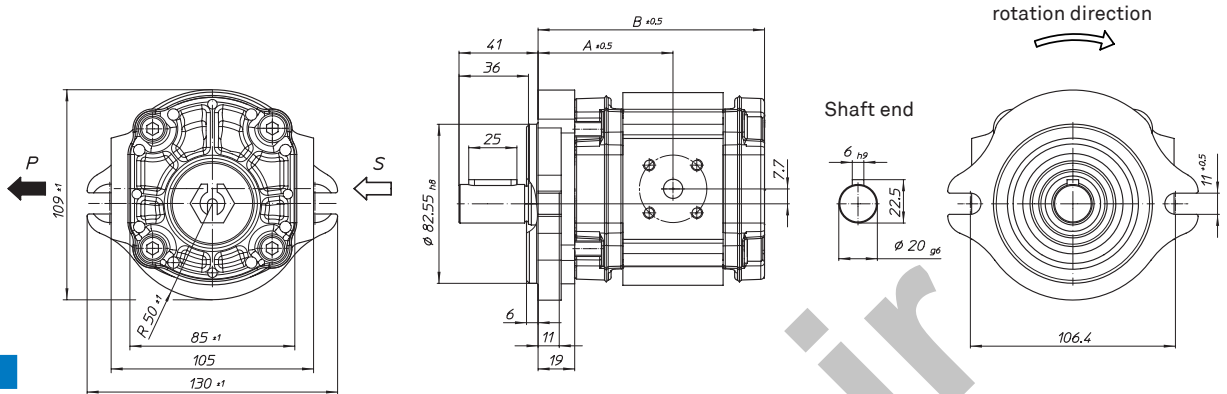

Size	A	B
005	62	101,5
006	63	103,5
008	64,5	106,5
011	67,5	112,5
013	70	117,5
016	72,5	122,5
019	76	129,5
022	79	135,5
025	82	141,5

SAE-B flange on request

Pump with straight keyed shaft

Order example: EIPS2 - _ _ _ RA34-1X

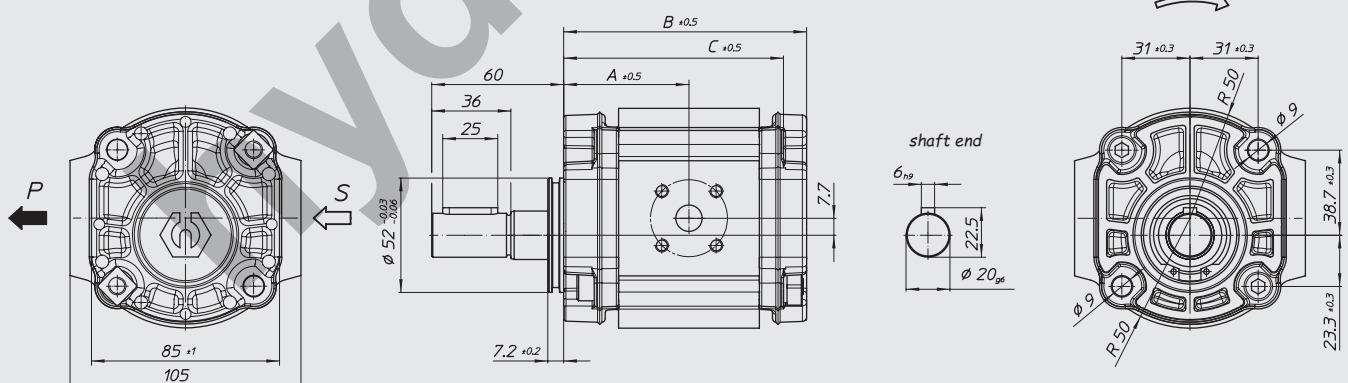

Size	A	B	C
005	43	82.5	72
006	44	84.5	74
008	45.5	87.5	77
011	48.5	93.5	83
013	51	98.5	88
016	53.5	103.5	93
019	57	110.5	100
022	60	116.5	106
025	63	122.5	112

Provide M8 DIN 912 fastening screws with DIN 433 plain washer, tightening torque M=25+5 Nm

Double pump with SAE 2-bolt flange and straight keyed shaft

Order example: EIPS2 - ___RK04-1X S111+
EIPS2 - ___RD34-1X S111

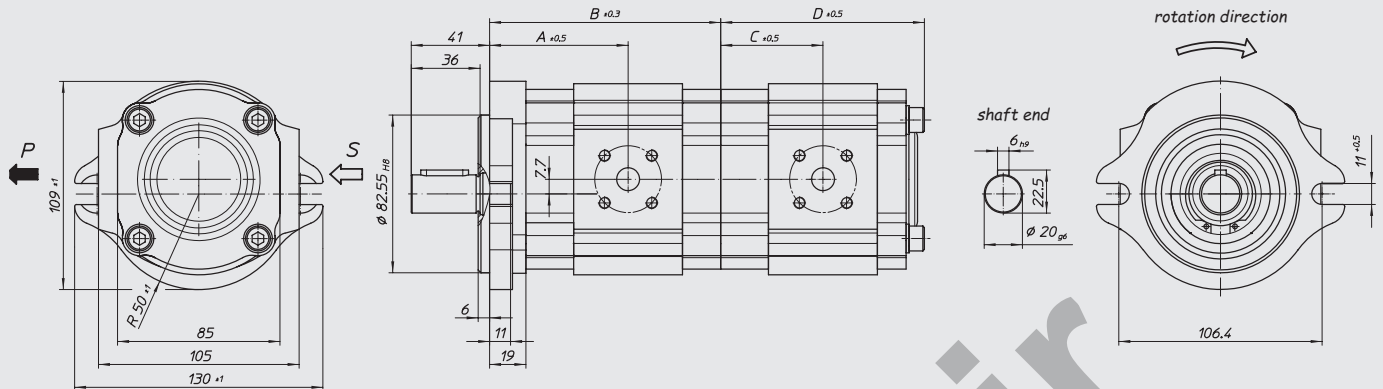

Size	A	B	C	D
005	62	100	43	85.5
006	63	102	44	87.5
008	64.5	105	45.5	90.5
011	67.5	111	48.5	96.5
013	70	116	51	101.5
016	72.5	121	53.5	106.5
019	76	128	57	113.5
022	79	134	60	119.5
025	82	140	63	125.5

The single pumps of a multiple pump assembly are internally connected, even if you connect to the pump inlet. It is therefore no operating with different fluids possible.

Pump with adaption, bold pattern of former Eckerle IPF 3 pumps

Order example: EIPS2 - ___LD34-1X S112

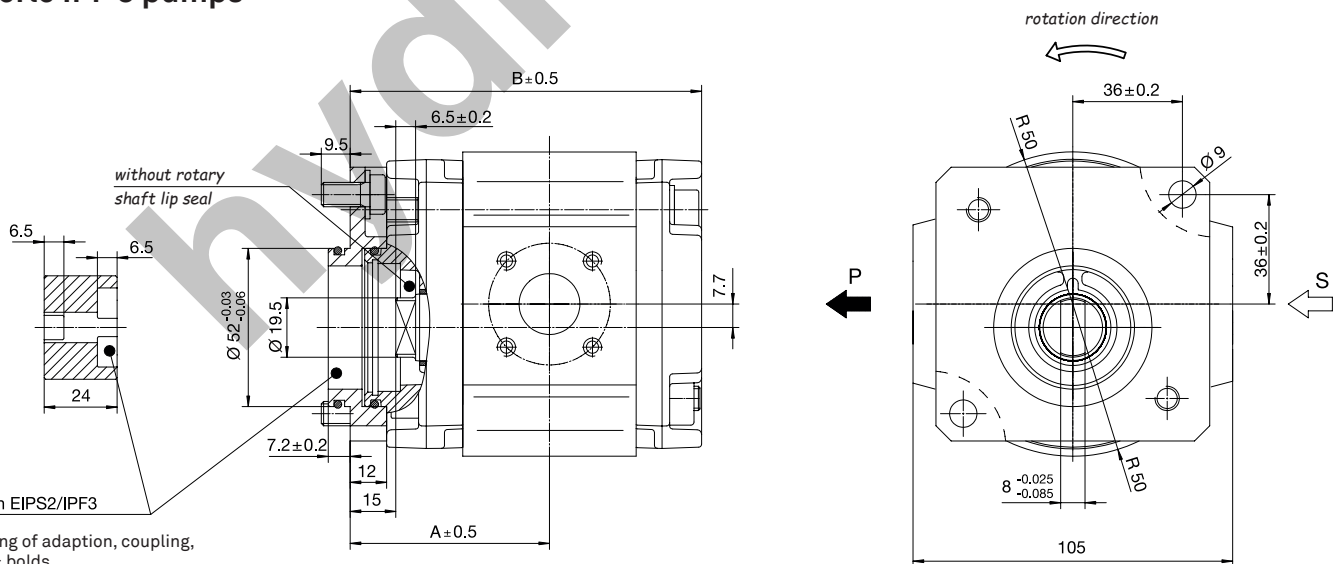

Adaption EIPS2/IPF3
consisting of adaption, coupling,
O-ring & bolts
Ident.-No. 640 030 000 0

Size	A	B
011	60,5	105,5
013	63	110,5
016	65,5	115,5
019	69	122,5
022	72	128,5

Double pump with SAE 2-bolt flange and straight keyed shaft Order example: EIPS2 - ___SK04-1X S111+
EIPS1 - ___RD31-1X

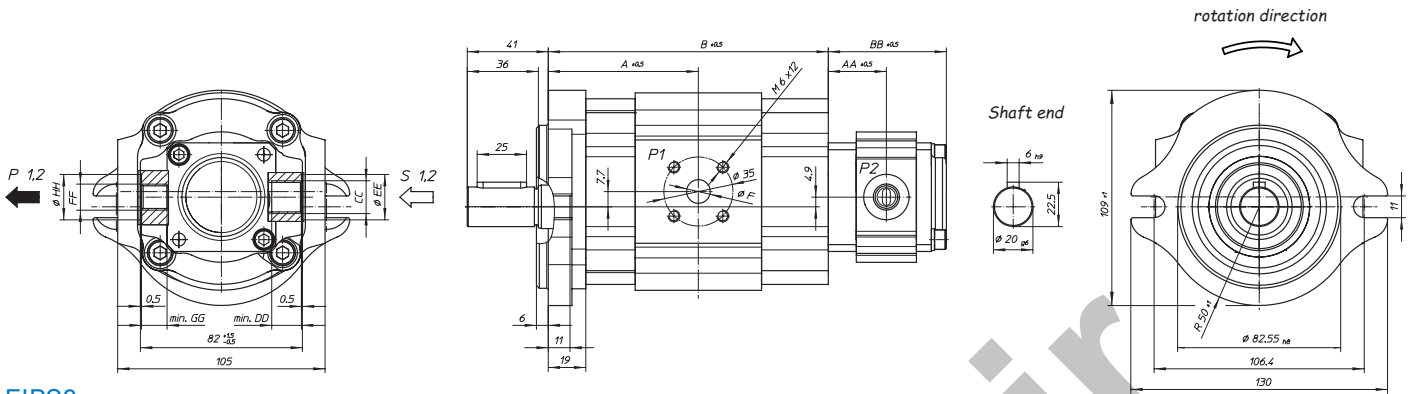

EIPS2

Size	A	B	F
005	62	113,8	5
006	63	115,8	5
008	64,5	118,8	7
011	67,5	124,8	10
013	70	129,8	10
016	72,5	134,8	12
019	76	141,8	12
022	79	147,8	12
025	82	153,8	12

EIPS1

Size	AA	BB	CC	DD	EE	FF	GG	HH
016	26,9	54,8	G 3/8"	12	23	G 1/4"	12	20
020	27,9	56,8	G 3/8"	12	23	G 1/4"	12	20
025	29,4	59,8	G 3/8"	12	23	G 1/4"	12	20
032	30,9	62,8	G 1/2"	14	28	G 3/8"	12	23
040	32,9	66,8	G 1/2"	14	28	G 3/8"	12	23
050	35,4	71,8	G 1/2"	14	28	G 3/8"	12	23

The single pumps of a multiple pump assembly are internally connected, even if you connect to the pump inlet. It is therefore no operating with different fluids possible.

Intake and outlet connections

Intake and outlet connections

Intake connection

Size 005-016 Size 019-025

Outlet connection

Size 005-025

Thread depth M6 and M8 = 12 mm
All dimensions stated in mm
- other connections on request -

Flange connection 90° – 24° DIN 3901

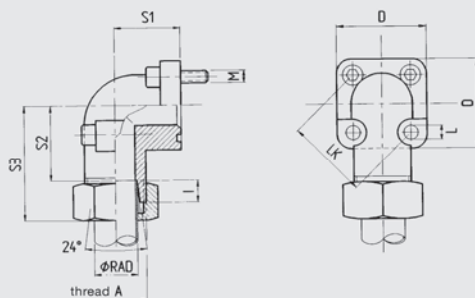
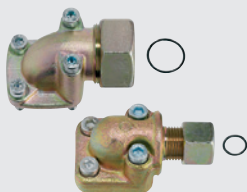

Type	Article number	LK	A	RAD	D	S1	S2	S3	L	Bolts	O-Ring	Weight	p max
WV-AD 12/35LK-C	0707040013	35	M18x1,5	L12	39	16,5	30,5	47	6,4	2xM6x22 2xM6x35	20x2,5	0,13	315 bar
WV-AD 16/35LK-C	0707040014	35	M24x1,5	L16	39	20	29,5	48	6,4	2xM6x22 2xM6x40	20x2,5	0,17	315 bar
WV-AD 28/40LK-C	0707040015	40	M36x2	L28	42	28	32,5	49	6,4	2xM6x22 2xM6x50	26x2,5	0,27	100 bar
WV-AD 35/55LK-C	0707040016	55	M45x2	L35	58	32	38,5	62	8,4	2xM8x25 2xM8x60	32x2,5	0,46	100 bar

4-bolt flange 90° BSPP-threaded steel

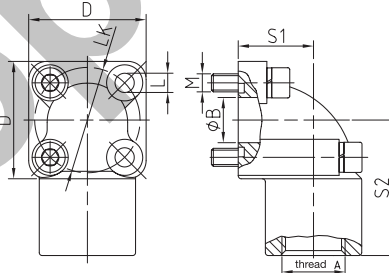

Type	Article number	LK	A	B	D	S1	S2	L	Bolts	O-Ring	Weight	p max
WV-G3/8-35LK-C	0707040021	35	G3/8"	15	39	25	45	6,4	2xM6x22 2xM6x45	20x2,5	0,27	315 bar
WV-G1/2-35LK-C	0707040022	35	G1/2"	15	39	25	45	6,4	2xM6x22 2xM6x45	20x2,5	0,25	315 bar
WV-G3/4-40LK-C	0707040023	40	G3/4"	20	42	28	50	6,4	2xM6x22 2xM6x50	26x2,5	0,38	160 bar
WV-G1-55LK-C	0707040025	55	G1"	26	58	40	59	8,4	2xM8x25 2xM8x70	32x2,5	0,87	160 bar

Flange connection – straight 24° DIN 3901

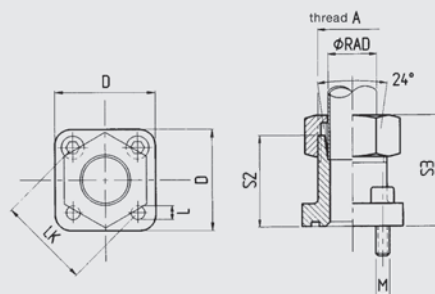
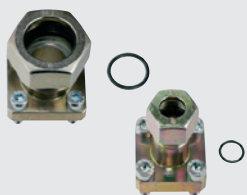

Type	Article number	LK	A	RAD	D	S2	S3	L	Bolts	O-Ring	Weight	p max
V-AD 12/35LK-C	0707040017	35	M18x1,5	L12	39	30	39	6,4	4xM6x22	20x2,5	0,09	315 bar
V-AD 16/35LK-C	0707040018	35	M24x1,5	S16	39	30	39,5	6,4	4xM6x22	20x2,5	0,11	315 bar
V-AD 28/40LK-C	0707040019	40	M36x2	L28	42	42	44,5	6,4	4xM6x22	26x2,5	0,16	100 bar
V-AD 35/55LK-C	0707040020	55	M45x2	L35	55	50	61	8,4	4xM8x25	32x2,5	0,3	100 bar

EIP S2 - 011 RA34 - 10 S111

Special version number

For example: S111 light industrial version

Revision code

1st number: Change of external dimensions
2nd number: Internal modifications

Intake and outlet connection

1: Threaded connector ISO 228
– other connections on request – (EIPS1)
4: Square flanged connection
in accordance with DIN 3901/3902
– other connections on request – (EIPS2)

Mounting flange

0: SAE-AA-2-Bolt flange Ø 50,8 (only EIPS1)
0: SAE-A-2-Bolt flange Ø 82,55
2: SAE-B-2-Bolt flange Ø 101,6
3: Direct mounting
– other flanges on request –

Shaft end

A: straight keyed	K: straight keyed with tang shaft PTO
B: SAE splined shaft	L: SAE splined with PTO
D: Tang shaft	N: Tang shaft both sides

Rotation direction

R: Clockwise | L: Counterclockwise
(S: Clockwise rated size 1/2)

Rated size

Three digits

Frame size 1 or 2

Type

S: Segmental pump

Eckerle internal gear pump

Order example

EIPS2-005LD34-10

Segmental pump frame size 2 with 5.4 cm³/rev., counterclockwise rotation, tang shaft, direct mounting, square flange connection, revision code 10

EIPS1-050RD31-10

Segmental pump frame size 1 with 5.0 cm³/rev., clockwise rotation, tang shaft, direct mounting, threaded connector, revision code 10

Volume flow

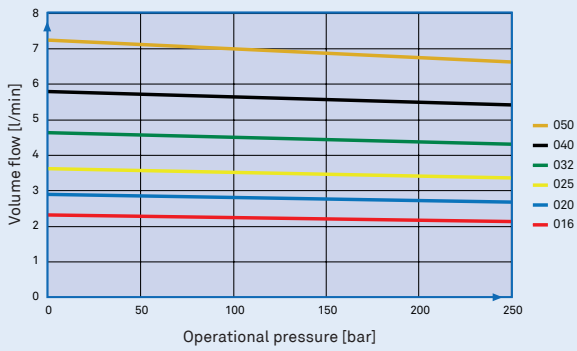

Level of efficiency

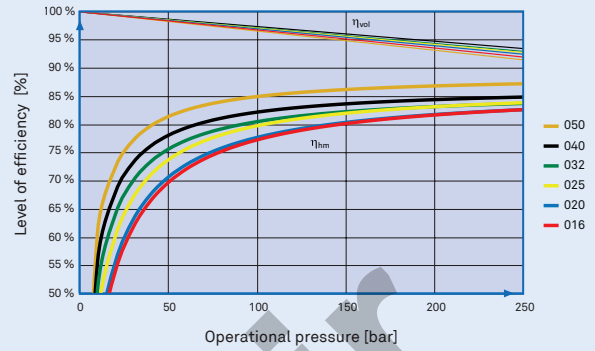

Driving power

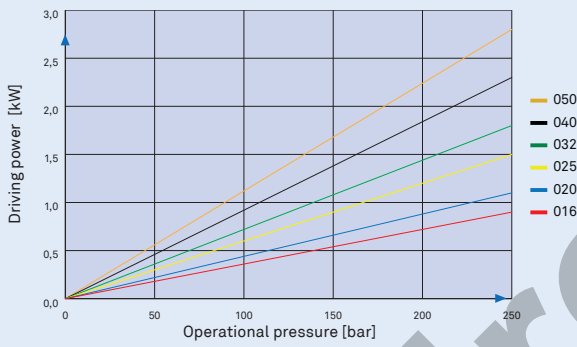

Sound level pressure in air

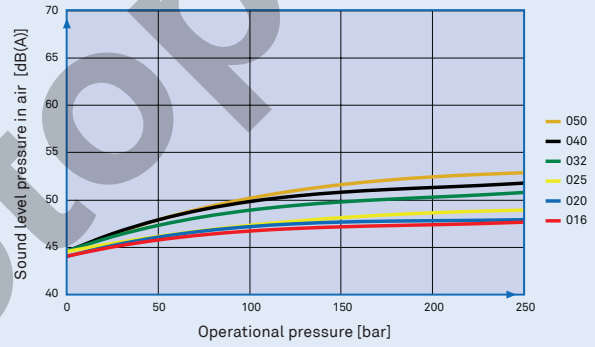

Measurement conditions: Speed 1450 rpm, viscosity 46 mm²/sec., operating temperature 40 °C, Sound pressure measured in low-reflection anechoic room in accordance with DIN 45 635 sheet 26; Microphone distance 1.0 m axial.

All indicated data serve alone the product description and are not as characteristics in the legal sense to be understood. Subject to alterations.

Volume flow

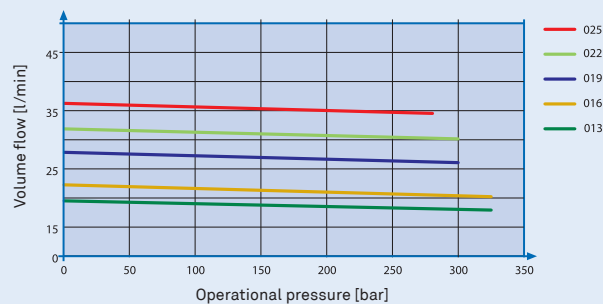
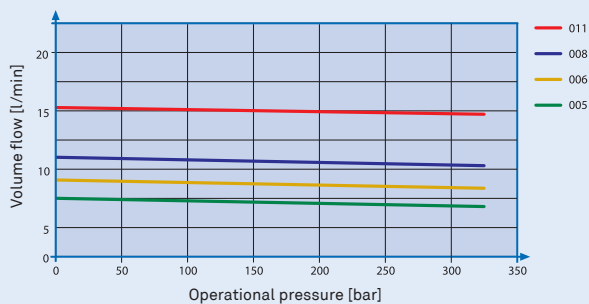

Level of efficiency

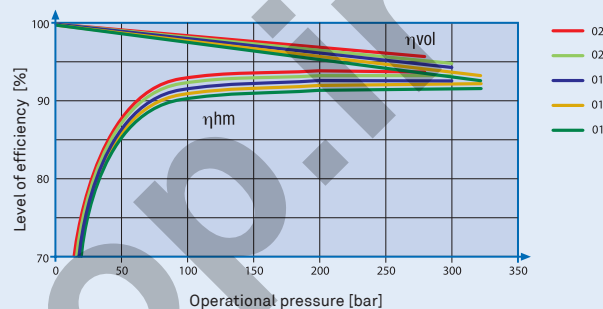
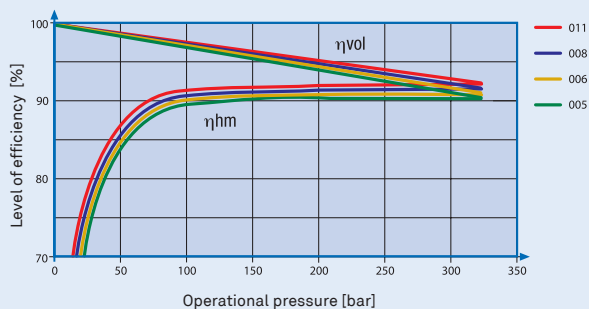

Driving power

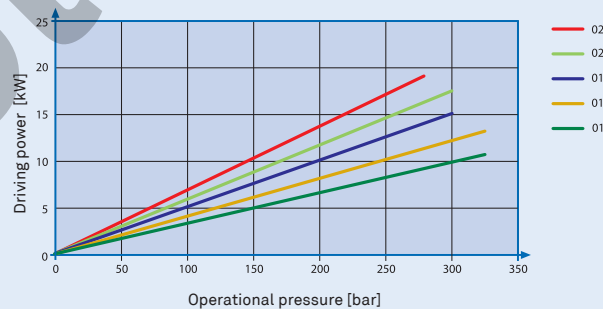
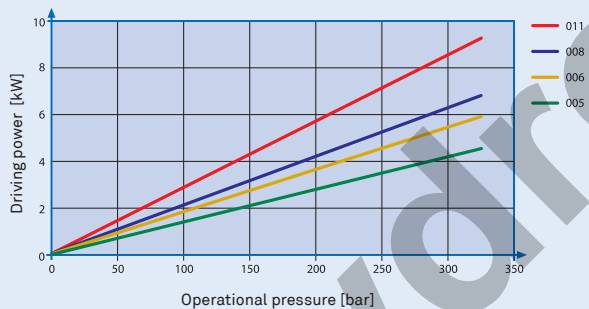

Sound level pressure in air

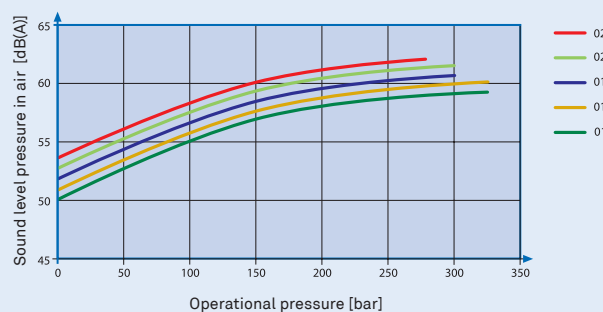
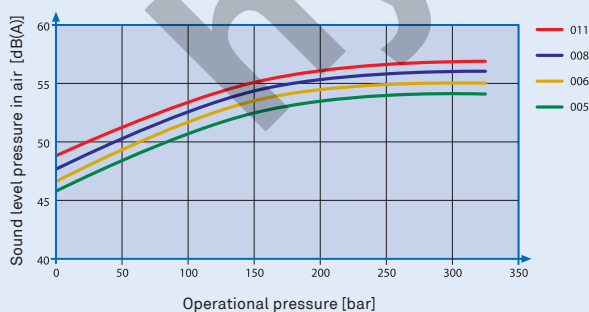

Measurement conditions: Speed 1450 rpm, viscosity 46 mm²/sec., operating temperature 40 °C, Sound pressure measured in low-reflection anechoic room in accordance with DIN 45 635 sheet 26; Microphone distance 1.0 m axial.

All indicated data serve alone the product description and are not as characteristics in the legal sense to be understood. Subject to alterations.