

**HEMA**  
**ENDÜSTRİ A.Ş.**

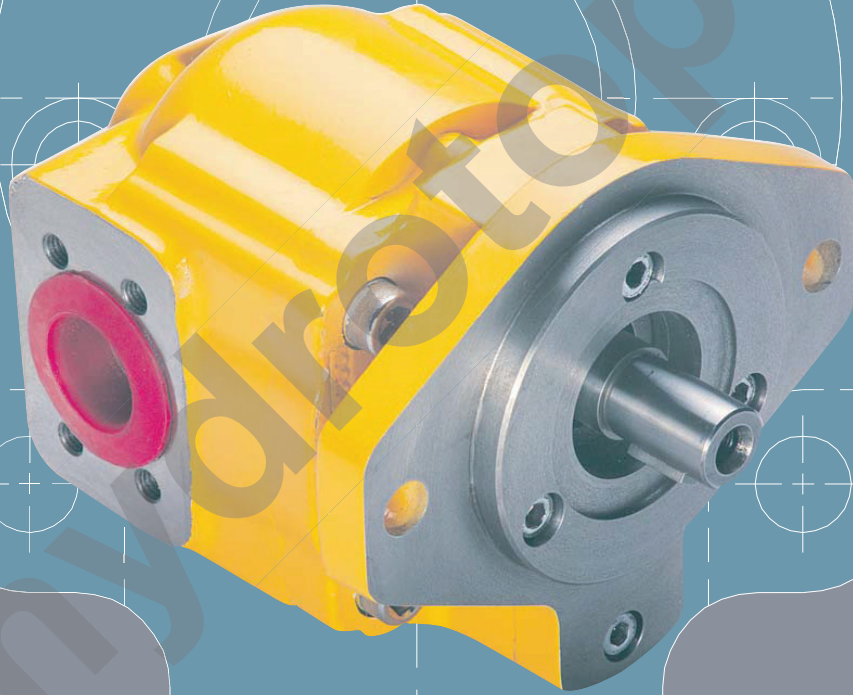

**HİDROLİK DİŞLİ POMPALAR / HYDRAULIC GEAR PUMPS**

**Q**

**SERİSİ / SERIES**

Bu katalog, tüm Q4, Q5, Q6 ve Q7 serisi tekli, ikili ve çoklu pompaların düz ve helisel dişli tiplerini içerir. Her pompa serisinin üçlü, hatta dörtlü bağlanması mümkündür fakat burada tüm bağlama kombinasyonlarından bahsedilmemiştir. Ayrıntılı bilgi için Hema Endüstri A.Ş.'ye başvurunuz. Çoklu pompaların toplam uzunlukları sayfa 40'ta gösterilmiştir

4., 6. ve 7. sayfalardaki "Bir bakışta pompa değerleri" ve model numarası kodlama sistemi, pompa seçmenizi ve pompa model numarası oluşturmanızı sağlar.

This brochure covers in detail, single, double and multiple pumps of each of the 4 frame sizes Q4, Q5, Q6 and Q7 in spur gear (R) and helical gear (S) types. It is possible to connect pumps of different sizes as triples or even quadruple units but is not practicable to cover the huge number of permutations in a publication of this type. Please consult Hema Endüstri A.S. Overall dimensions of these multiple pumps are shown on page 40.

"At a Glance" and Model Number details to enable you to select a pump and create its model number are shown on Pages 4, 6 and 7.

İÇİNDEKİLER / INDEX		SAYFA / PAGE
Bir Bakışta Pompa Değerleri / At a Glance Rating		4
Tanım ve Avantajları / Description & Benefits		5
Model Numarası Kodlama Sistemi / Model Number Code Structure		6 - 7
Çalışma Şartları / Operating parameters		8
Giriş Şartları / Inlet Conditions		8
QR4 / QS4	Boyutsal Veriler / Dimensional Data	9 - 10
	Performans Eğrileri / Performance Data	11
	Verim, Gürültü Seviyesi, Eylemsizlik Momenti / Efficiencies, Noise Levels, Moments Of Inertia	12
	Şaft Keçeleri ve Tahrik Milleri / Shaft Seals & Drive Shafts	13
	Ön Kapaklar / Mounting Flanges	14
	Delik Konumları, Tipleri ve Ölçüleri / Port Positions, Types & Dimensions	15 - 16
QR5 / QS5	Boyutsal Veriler / Dimensional Data	17 - 18
	Performans Eğrileri / Performance Data	19
	Verim, Gürültü Seviyesi, Eylemsizlik Momenti / Efficiencies, Noise Levels, Moments Of Inertia	20
	Şaft Keçeleri ve Tahrik Milleri / Shaft Seals & Drive Shafts	21
	Ön Kapaklar / Mounting Flanges	22
	Delik Konumları, Tipleri ve Ölçüleri / Port Positions, Types & Dimensions	23 - 24
QR6 / QS6	Boyutsal Veriler / Dimensional Data	25 - 26
	Performans Eğrileri / Performance Data	27
	Verim, Gürültü Seviyesi, Eylemsizlik Momenti / Efficiencies, Noise Levels, Moments Of Inertia	28
	Şaft Keçeleri ve Tahrik Milleri / Shaft Seals & Drive Shafts	29
	Ön Kapaklar / Mounting Flanges	30
	Delik Konumları, Tipleri ve Ölçüleri / Port Positions, Types & Dimensions	31 - 32
QS7	Boyutsal Veriler / Dimensional Data	33 - 34
	Performans Eğrisi / Performance Data	34
	Verim, Gürültü Seviyesi, Eylemsizlik Momenti / Efficiencies, Noise Levels, Moments Of Inertia	35
	Şaft Keçeleri ve Tahrik Milleri / Shaft Seals & Drive Shafts	36
	Ön Kapaklar, Delikler ve Delik Detayları / Mounting Flanges, Ports and Port Details	37 - 38
Q Serisi Çoklu Pompalar / Q Series Multiple Pumps		39 - 40

Sipariş geçmeden önce, pompanın belirtilen basınç, sıcaklık, hız ve akışkan parametreleri içerisinde çalışacağından ve pD faktörünü aşmadığından emin olunması gerekir. (Sayfa 13, 21, 29, 36 ve 39'a bakınız.)

Before ordering, please ensure that the pump will be operating within quoted pressure, temperature, speed and fluid parameters and that the pD factors are not exceeded (see pages 13, 21, 29, 36 and 39).

QR SERİSİ / QR SERIES Düz Dişliler / Spur Gears				QS SERİSİ / QS SERIES Helisel Dişliler / Helical Gears			
MODEL	İLETİM HACMİ DISPLACEMENT cm <sup>3</sup> /dev - cm <sup>3</sup> /rev (in <sup>3</sup> /dev - in <sup>3</sup> /rev)	ÇALIŞMA BASINCI RATED PRESSURE bar (psi)	ANİ BASINÇ PEAK PRESSURE bar (psi)	MODEL	İLETİM HACMİ DISPLACEMENT cm <sup>3</sup> /dev - cm <sup>3</sup> /rev (in <sup>3</sup> /dev - in <sup>3</sup> /rev)	ÇALIŞMA BASINCI RATED PRESSURE bar (psi)	ANİ BASINÇ PEAK PRESSURE bar (psi)
R4016	16 (0.975)	250 (3625)	280 (4060)	S4016	16 (0.975)	250 (3625)	280 (4060)
R4019	19 (1.158)	250 (3625)	280 (4060)	S4023	22.2 (1.341)	250 (3625)	280 (4060)
R4023	23 (1.402)	250 (3625)	280 (4060)	S4027	26.1 (1.585)	250 (3625)	280 (4060)
R4027	27 (1.646)	250 (3625)	280 (4060)	S4032	30.9 (1.884)	250 (3625)	280 (4060)
R4032	32 (1.951)	250 (3625)	280 (4060)	S4037	35.8 (2.183)	250 (3625)	280 (4060)
R4038	38 (2.317)	250 (3625)	280 (4060)	S4042	40.6 (2.476)	210 (3045)	235 (3408)
R4045	45 (2.746)	250 (3625)	280 (4060)	S5045	43.5 (2.652)	250 (3025)	280 (4060)
R4053	53 (3.230)	210 (3045)	235 (3408)	S5051	49.3 (3.006)	250 (3025)	280 (4060)
R4060	60 (3.660)	180 (2610)	200 (2900)	S5060	58.0 (3.537)	250 (3025)	280 (4060)
R5045	45 (2.746)	250 (3625)	280 (4060)	S5070	67.7 (4.128)	250 (3025)	280 (4060)
R5053	53 (3.231)	250 (3625)	280 (4060)	S5085	82.2 (5.012)	210 (3045)	235 (3408)
R5063	63 (3.841)	250 (3625)	280 (4060)	S6083	80.3 (4.896)	250 (3625)	280 (4060)
R5073	73 (4.451)	250 (3625)	280 (4060)	S6097	93.8 (5.720)	250 (3625)	280 (4060)
R5085	85 (5.183)	250 (3625)	280 (4060)	S6113	109.3 (6.665)	250 (3625)	280 (4060)
R5100	100 (6.098)	210 (3045)	235 (3408)	S6132	127.6 (7.780)	250 (3625)	280 (4060)
R5120	120 (7.317)	180 (2610)	200 (2900)	S6155	149.9 (9.140)	210 (3045)	235 (3408)
R6100	100 (6.098)	250 (3625)	280 (4060)	S7155	149.9 (9.140)	250 (3625)	280 (4060)
R6117	117 (7.134)	250 (3625)	280 (4060)	S7180	174.1 (10.615)	250 (3625)	280 (4060)
R6137	137 (8.354)	250 (3625)	280 (4060)	S7208	201.1 (12.262)	250 (3625)	280 (4060)
R6160	160 (9.756)	250 (3625)	280 (4060)	S7248	239.8 (14.622)	250 (3625)	280 (4060)
R6187	187 (11.402)	210 (3045)	235 (3408)				
R6220	220 (13.415)	180 (2610)	200 (2900)				

Not / Note :

$$\begin{aligned} \text{Teorik debi} &= \frac{\text{cm}^3/\text{dev} \times \text{dev}/\text{dak}}{1000} && (\text{lt}/\text{dak}) \\ &= 0.00433 \times \text{in}^3/\text{dev} \times \text{dev}/\text{dak} && (\text{US gal}/\text{dak}) \end{aligned}$$

$$\begin{aligned} \text{Theoretical flow rate} &= \frac{\text{cm}^3/\text{rev} \times \text{rev}/\text{min}}{1000} && (\text{lt}/\text{min}) \\ &= 0.00433 \times \text{in}^3/\text{rev} \times \text{rev}/\text{min} && (\text{US gal}/\text{min}) \end{aligned}$$

Pazar ihtiyaçlarını karşılamak için yüksek verimli ve sessiz QR ve QS serisi pompalar geliştirilmiştir.

Dökme demir ve yüksek kaliteli çelik dişlilerden oluşan her iki pompa serisi, giriş deliğinden soğuk yağ çeken bir sistem tarafından yağlanan hidrodinamik kaymalı yataklarla(burç) desteklenir.

QR serisi düz dişli pompalar, minimum basınç dalgalanması için tasarlanmasının yanında patentli özelliklere sahip QS serisi helisel dişli pompalar gürültü seviyesini ve basınç dalgalanmasını daha fazla düşürür.

Pompalar 280 bar'a (4060psi) kadar ani basınçlara çıkabilir ve giriş deliğinin düzgün bağlantısı ile 3000 dev/dak dönme hızlarında çalışabilir.

In response to market needs, the QR and QS ranges have been developed to combine very high efficiencies with very low noise levels.

Both series are of cast iron construction and high quality steel gears are supported by hydrodynamic plain (bush) bearings which are lubricated by a system which draws cool fluid from the inlet port.

QR spur gear pumps are designed for minimum pressure ripple while the QS Series features patented helical gears, which reduce ripple, and noise levels even further.

The pumps will work to peak pressures up to 280 bar (4060 psi) and careful attention to inlet porting enables most pumps to run at up to 3000 rev/min.

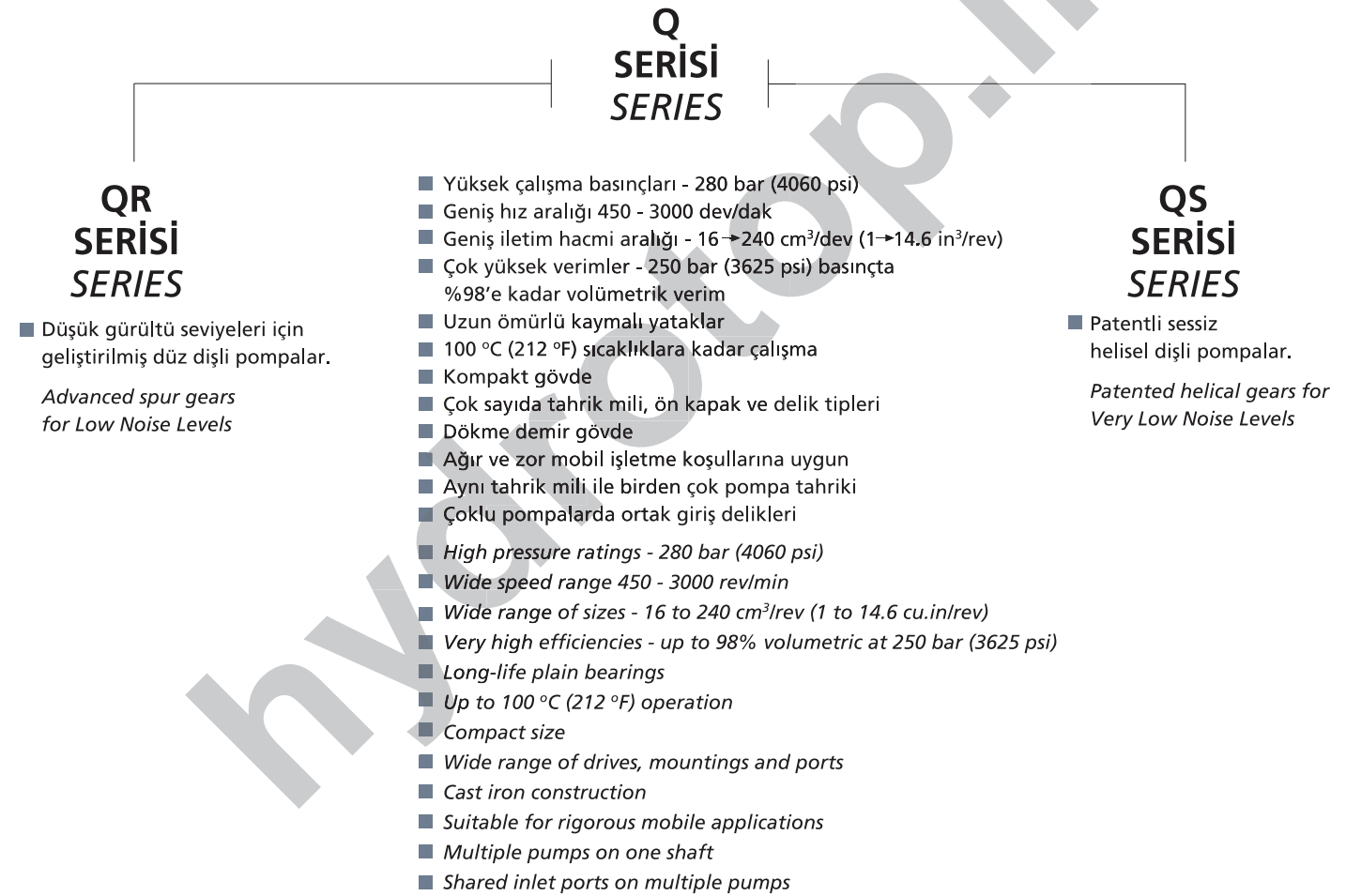

**R 1 A 4 0 1 6 R 4 0 1 6 B 1 2 A 1 H 1 A 0 X 1 A A**Ön veya tekli pompa  
Front or single pumpArka pompa  
(tekli pompalarda yok)  
Rear pump  
(Omit for single pumps)Ön veya tekli pompa delikleri için  
For front or single pump portsArka pompa delikleri için  
For rear pump ports

- R** 1 Dişli tipi / Gear type
- 1** Tasarım seviyesi / Design mark
- A** 2 Şaft keçesi / Shaft seal
- 4016** 3 Seri tipi ve iletim hacmi / Frame size and displacement
- R** 1 Dişli tipi / Gear type
- 4016** 3 Seri tipi ve iletim hacmi / Frame size and displacement
- B** 4 Tahrik mili tipi / Drive shaft type
- 1** 5 Ön kapak tipi / Mounting flange type
- 2** 7 Pompa sayısı / Number of pump sections
- A** 6 Giriş deliği konumu / Inlet port position
- 1** 8 Giriş deliği tipi / Inlet port type
- H** 10 Giriş deliği ölçüsü / Inlet port size
- 1** 9 Çıkış deliği tipi / Outlet port type
- A** 11 Çıkış deliği ölçüsü / Outlet port size
- 0** 8 Giriş deliği tipi / Inlet port type
- X** 10 Giriş deliği ölçüsü / Inlet port size
- 1** 9 Çıkış deliği tipi / Outlet port type
- A** 11 Çıkış deliği ölçüsü / Outlet port size
- A** 12 Dönüş yönü / Rotation

Dişli tipleri Gear types		1
R	Düz dişli / Spur gear	
S	Helisel dişli / Helical gear	

Şaft keçeleri Shaft seals		2
A	Keçe ve toz keçesi Seal and wiper	
C	Toz keçesi, kaçak kontrol delikli keçe Seal wiper, seal with tell-tale	

Seri tipi ve iletim hacimleri Frame sizes and displacements						3	
R	Serisi Series	cm <sup>3</sup> /dev cm <sup>3</sup> /rev	in <sup>3</sup> /dev in <sup>3</sup> /rev	S	Serisi Series	cm <sup>3</sup> /dev cm <sup>3</sup> /rev	in <sup>3</sup> /dev in <sup>3</sup> /rev
	R4016	16.0	0.975		S4016	16.0	0.975
	R4019	19.0	1.158		S4023	22.2	1.341
	R4023	23.0	1.402		S4027	26.1	1.585
	R4027	27.0	1.646		S4032	30.9	1.884
	R4032	32.0	1.951		S4037	35.8	2.183
	R4038	38.0	2.317		S4042	40.6	2.476
	R4045	45.0	2.746		S5045	43.5	2.652
	R4053	53.0	3.230		S5051	49.3	3.006
	R4060	60.0	3.660		S5060	58.0	3.537
	R5045	45.0	2.746		S5070	67.7	4.128
	R5053	53.0	3.231		S5085	82.2	5.012
	R5063	63.0	3.841		S6083	80.3	4.896
	R5073	73.0	4.451		S6097	93.8	5.720
	R5085	85.0	5.183		S6113	109.3	6.665
	R5100	100.0	6.098		S6132	127.6	7.780
	R5120	120.0	7.317		S6155	149.9	9.140
	R6100	100.0	6.098		S7155	149.9	9.140
	R6117	117.0	7.134		S7180	174.1	10.615
	R6137	137.0	8.354		S7208	201.1	12.262
	R6160	160.0	9.756		S7248	239.8	14.622
	R6187	187.0	11.402				
	R6220	220.0	13.415				

Bu kodlama sistemi, standart dual ve ikili pompa model numaraları içindir. Özel durumlar, üçlü ve dördümlü pompalar için Hema Endüstri A.Ş.'ye başvurunuz.

Sipariş geçmeden önce, pompanın belirtilen basınç, sıcaklık, hız ve akışkan parametreleri içerisinde çalışacağı ve pD faktörünü aşmadığı kontrol edilmelidir. (Sayfa 39'a bakın.)

Use this coding system to compile standard dual and double pump model numbers. For special features and for triple and quadruple pumps please consult Hema Endustri A.S.

Before ordering, please check that the pump will be operating within quoted pressure, temperature, speed and fluid parameters and that the pD factors are not exceeded (see page 39).

Tahrik mili tipleri Drive shaft types				4			
Kod Code	Açıklama Description	Seri tipi Frame sizes					
A	5/8" SAE A spline	4					
E	5/8" SAE A paralel / parallel	4					
B	7/8" SAE B spline	4	5				
F	7/8" SAE B paralel / parallel	4					
Q	1" SAE BB spline	4	5				
H	1" SAE BB paralel / parallel	4	5				
C	1.1/4" SAE C spline		5	6	7		
G	1.1/4" SAE C paralel / parallel		5	6	7		
T	1.1/2" SAE CC spline			6	7		
N	1.1/2" SAE CC paralel / parallel			6	7		
D	1.3/4" SAE D spline				7		
P	1.3/4" SAE D paralel / parallel				7		
Bu sayfalara bakınız./ See page number.		13	21	29	36		

Pompa sayısı Number of pump sections		7	
Kod Code	Açıklama Description		
1	1 pompa / 1 pump section		
2	2 pompa / 2 pump sections		
3	3 pompa / 3 pump sections		
4	4 pompa / 4 pump sections		

Ön kapak tipleri Mounting Flanges				5			
Kod Code	Açıklama Description	Seri tipi Frame sizes					
1	SAE A - 2 civatalı / bolt	4					
2	SAE B - 2 civatalı / bolt	4	5				
3	SAE B - 4 civatalı / bolt	4	5				
4	SAE C - 2 civatalı / bolt	4	5	6			
5	SAE C - 4 civatalı / bolt	4	5	6	7		
7	SAE D - 4 civatalı / bolt				7		
Bu sayfalara bakınız./ See page number.		14	22	30	37		

Giriş deliği tipleri Inlet port types		8	
Kod Code	Açıklama Description		
0	Deliksiz / No port		
1	SAE split flanş - metrik civatalar - Kod 61 SAE split flange - metric bolts - Code 61		
2	SAE split flanş - UNC civatalar - Kod 61 SAE split flange - UNC bolts - Code 61		
3	BSPP		
4	SAE UNF O-ring		

Bu sayfalara bakınız : 16, 24, 32 & 38  
See pages :

Giriş deliği konumları Inlet port positions					6	
Kod Code	Açıklama Description	Tekli pompa Single pump	İkili pompa Double pump	Dual Pompa Dual pump		
A	Giriş deliği ön pompada / Inlet port in front section	✓	✓			
B	Giriş delikleri ayrı / Separate inlet ports		✓			
C	Giriş delikleri ortak / Common inlet port			✓		

Bu sayfalara bakınız : 15, 23, 32 & 38  
See pages :

Çıkış deliği tipleri Outlet port types		9	
Kod Code	Açıklama Description		
1	SAE split flanş - metrik civatalar - Kod 61 SAE split flange - metric bolts - Code 61		
2	SAE split flanş - UNC civatalar - Kod 61 SAE split flange - UNC bolts - Code 61		
3	BSPP		
4	SAE UNF O-ring		

Bu sayfalara bakınız : 16, 24, 32 & 38  
See pages :

Giriş deliği ölçüleri Inlet port sizes				10	
Kod code	Çap size	Kod code	Çap size		
A	1/2	H	1.1/2		
B	3/4	J	1.5/8		
C	7/8	K	2		
D	1	L	2.1/2		
E	1.1/16	M	3		
F	1.1/4	N	4		
G	1.5/16	X	Delik yok No port		

Bu sayfalara bakınız : 16, 24, 32 & 38  
See pages :

Çıkış deliği ölçüleri Outlet port sizes				11	
Kod code	Çap size	Kod code	Çap size		
A	1/2	F	1.1/4		
B	3/4	H	1.1/2		
D	1	J	1.5/8		
E	1.1/16	K	2		

Bu sayfalara bakınız : 16, 24, 32 & 38  
See pages :

Dönüş yönü Rotation		12	
A	Saat yönü tersi / Anti - clockwise		
C	Saat yönünde / Clockwise		

**ÇALIŞMA ŞARTLARI / OPERATING PARAMETERS**

Q Serisi pompalar belirtilen değerler içinde çalıştırıldığında yüksek performans elde edilecek ve çalışma ömrü uzun olacak şekilde tasarlanmıştır. Bu değerlerin dışında kullanılması durumunda HEMA Endüstri A.Ş'ye başvurunuz.

Q Series pumps are designed to provide high performance levels and long life when operated within the parameters shown. For operation outside these parameters please consult Hema Endüstri A.S.

Maksimum çıkış basınçları / Maximum outlet port pressures		Sayfa 4'e bakınız. / See page 4.
Giriş basınçları / Inlet port pressures		Aşağıya bakınız. / See below.
Hız aralığı Speed range	Q4	450 - 3000 dev/dak / rev/min
	Q5	450 - 3000 dev/dak / rev/min
	Q6	450 - 2750 dev/dak / rev/min
	Q7	450 - 2400 dev/dak / rev/min
Sıcaklık Temperature	İlk çalışma anında minimum / Minimum at start-up	-40°C (-40°F)
	Sürekli çalışmada maksimum / Maximum continuous	+80°C (+176°F)
	Aralıklı çalışmada maksimum / Maximum intermittent	+100°C (+212°F)
Viskozite Viscosity	İlk çalışma anında maksimum / Maximum at start-up	2000 cSt (9000 SSU)
	Sürekli çalışmada maksimum / Maximum Continuous	250 cSt (1150 SSU)
	Sürekli çalışmada minimum / Minimum Continuous	10 cSt (60 SSU)
	Optimum / Optimum	15 - 25 cSt (78 - 124 SSU)
Yağ kirliliği ISO4406'ya göre Fluid cleanliness to ISO4406	İlk çalışma periyodunda / Start-up period	21/17
	Çalışma anında maksimum / Maximum in service	19/15
	Optimum / Optimum	16/11
	Maksimum su miktarı / Maximum water	0.1%
Akışkan hızı Fluid velocity	GİRİŞ hattındaki maksimum hız / Maximum in INLET line	2.5 m/s (8 ft/s)
	GİRİŞ hattındaki tavsiye edilen hız / Recommended in INLET line	1.5 m/s (5 ft/s)
Şaft yükleri Shaft loads	Maksimum eksenel yük / Maximum end load	250 N (56 lb)
	Maksimum radyal yük / Maximum radial load	500 N (112 lb)
Yağlar / Fluids	Tüm veriler HM ve HV mineral yağlar içindir. / All data is quoted for mineral oils HM and HV.	
Eylemsizlik momenti Moments of Inertia	12., 20., 28., 35. sayfalara bakınız. / See page 12, 20, 28, 35.	
Dönüş yönü Rotation	Tahrik mili tarafından bakıldığında; saat yönünde veya saat yönü tersi Clockwise or Anti-clockwise viewed from shaft end (not reversible)	

**GİRİŞ ŞARTLARI / INLET CONDITIONS**

Q Serisi pompaların kullanımında aşağıdaki tavsiyelere uyulması gerekir.

- Pompalar kesinlikle yağsız çalıştırılmamalıdır. Aç-kapa valflerini açarken dikkat edilmelidir.
- Büyük çapta boru ve bağlantı elemanları kullanılmalı, keskin köşe, dirsekler ile uzun bağlantılardan kaçınılmalıdır.  
Yağ giriş hızı \* 2.5m/s'yi geçmemelidir.
- Pompalar mümkün olduğunca tanktaki yağın en düşük seviyesinin altına yerleştirilmelidir.
- Giriş hattının hava emmediğinden emin olunmalıdır.
- Yüksek hızın olduğu ve/veya yüksek viskoziteli akışkan kullanıldığı durumlarda dikkatli olunması gerekir.

Genel bir kural olarak 23 cSt (110 SSU) viskozitede, pompanın giriş basıncı 0.8 bar'lık mutlak basınçtan düşük olmamalıdır.

\*Yağ hızı / fluid velocity

$$V = \frac{21.22 \times Q}{D^2}$$

V=hız / velocity (m/s)  
Q=debi (lt/dak) / flow rate (l/min)  
D=delik çapı / bore diameter (mm)

$$V = \frac{0.408 \times Q}{D^2}$$

V=hız / velocity (ft/s)  
Q=debi (gal/dak) / flow rate (gal/min)  
D=delik çapı / bore diameter (in)

Q Series pump inlet porting is designed to facilitate full volume fill but the following machine design recommendations should be followed.

- Never run pumps dry - particular care should be taken to open any shut-off valves.
- Use large diameter pipes and fittings and avoid sharp bends and long lengths.  
Fluid velocity\* should not exceed 2.5 m/sec (8.0 ft/sec)
- If possible mount the pump below the lowest level of fluid in the tank.
- Ensure that inlet lines are airtight.
- Particular care should be taken where high speeds and/or high fluid viscosities are involved.

As a general rule pressure at the pump inlet should not be less than 0.8 bar absolute (6" Hg) at normal viscosity of 23 cSt (110 SSU).

## Not / Note

Aşağıdaki çizimler saat yönü dönlüşlü pompalarıdır. Saat yönünün tersi dönlüşlü pompalarda giriş ve çıkış delikleri yer değişir. (Dönüş yönü tayini, tahrik mili tarafında bakışa göredir.)

Drawings show clockwise rotation pumps. For anti-clockwise rotation pumps reverse the inlet and outlet port positions. (Rotation convention – view from pump shaft end).

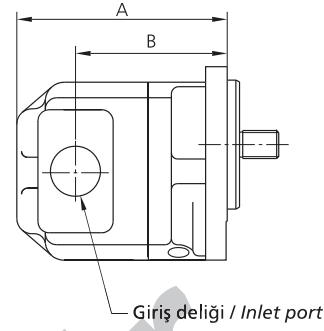
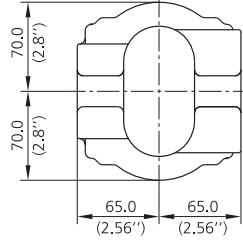
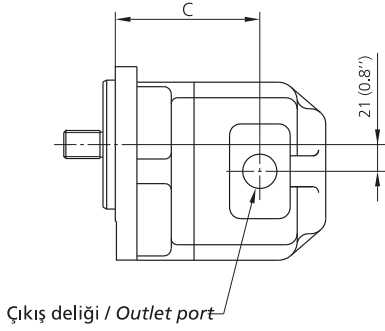
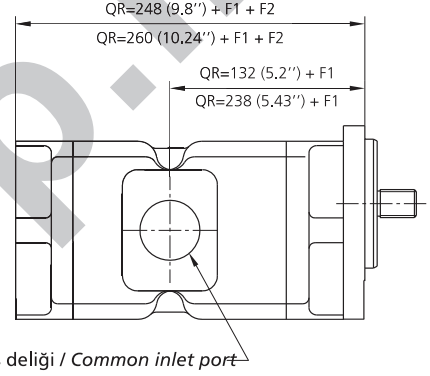
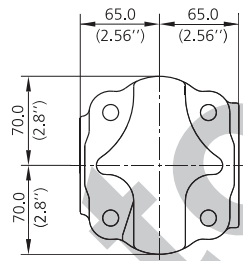
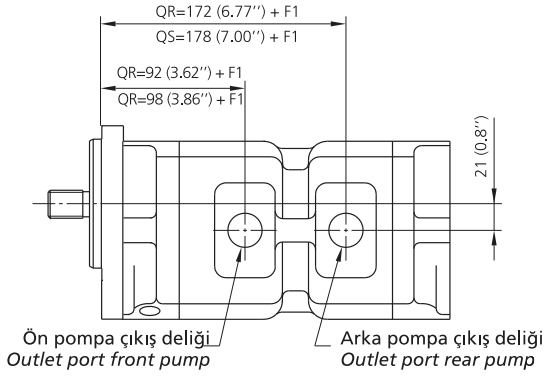
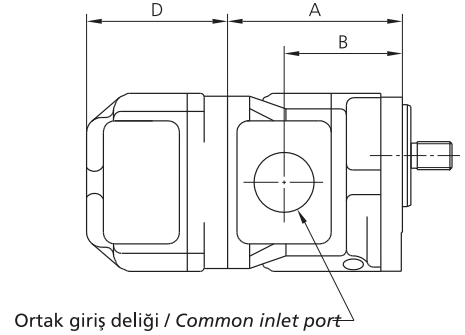
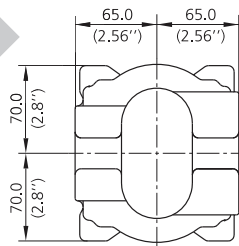
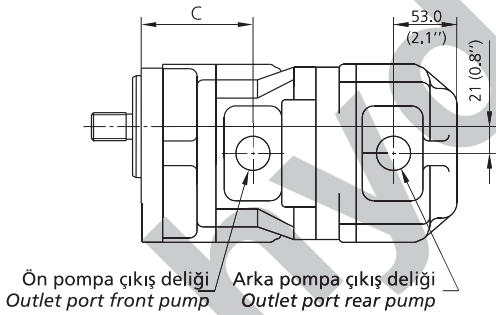
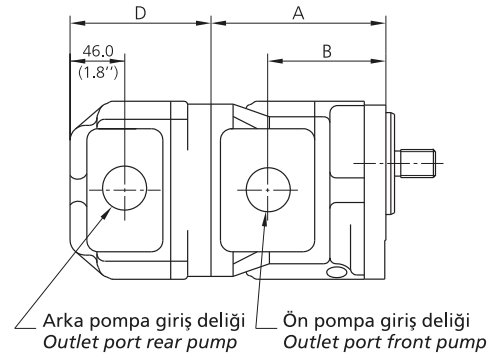
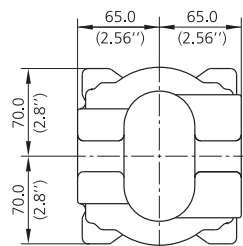
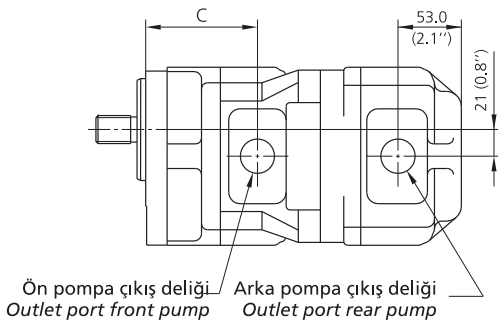
**TEKLİ POMPALAR - standart delikler**  
**SINGLE PUMPS - standard ports**
Kod **A**  
CodeÖrnek : R1A4016A11 **A** 1D1AC  
Example :
**DUAL POMPALAR - 1 giriş / 2 çıkış**  
**DUAL PUMPS - 1 inlet / 2 outlets**
Kod **C**  
CodeÖrnek : R1A4016R4016F12 **C** 1K1A0X1AC  
Example :
**İKİLİ POMPALAR - 1 giriş / 2 çıkış**  
**DOUBLE PUMPS - 1 inlet / 2 outlets**
Kod **A**  
CodeÖrnek : R1A4016R4016A12 **A** 1K1A0X1AC  
Example :
**İKİLİ POMPALAR - 2 giriş / 2 çıkış**  
**DOUBLE PUMPS - 2 inlets / 2 outlets**
Kod **B**  
CodeÖrnek : R1A4016R4016B12 **B** 1D1A1D1AC  
Example :
**ÜÇLÜ VE DÖRTLÜ POMPALAR - 39. ve 40. sayfalara bakınız.**  
**TRIPLE AND QUADRUPLE PUMPS - See pages 39 and 40.**



POMPA PUMP	A	B	C	D	F1 Ön Pompa Front Pump	F2 Arka Pompa Rear Pump	AĞIRLIK WEIGHT kg (lb)		
	mm (in)	mm (in)	mm (in)	mm (in)	mm (in)	mm (in)	Tekli* Single	Ön* Front	Arka* Rear
R4016	145.0 (5.71)	99.0 (3.90)	92.0 (3.62)	115.0 (4.53)	0	0	11.7 (25.7)	13.9 (30.6)	11.2 (24.6)
R4019	147.0 (5.79)	101.0 (3.98)	94.0 (3.70)	118.0 (4.65)	3.0 (0.12)	3.0 (0.12)	12.0 (26.4)	14.2 (31.2)	11.5 (25.3)
R4023	150.0 (5.91)	104.0 (4.09)	97.0 (3.82)	121.0 (4.76)	6.0 (0.24)	6.0 (0.24)	12.2 (26.8)	14.4 (31.7)	11.7 (25.7)
R4027	154.0 (6.06)	108.0 (4.25)	101.0 (3.98)	124.0 (4.88)	9.0 (0.35)	9.0 (0.35)	12.6 (27.7)	14.8 (32.6)	12.1 (26.6)
R4032	158.0 (6.22)	112.0 (4.41)	105.0 (4.13)	128.0 (5.04)	13.0 (0.51)	13.0 (0.51)	13.0 (28.6)	15.2 (33.4)	12.5 (27.5)
R4038	163.0 (6.42)	117.0 (4.61)	110.0 (4.33)	133.0 (5.24)	18.0 (0.71)	18.0 (0.71)	13.5 (29.7)	15.7 (34.5)	13.0 (28.6)
R4045	169.0 (6.65)	123.0 (4.84)	116.0 (4.67)	139.0 (5.57)	24.0 (0.94)	24.0 (0.94)	14.0 (30.8)	16.2 (35.6)	13.5 (29.7)
R4053	175.0 (6.89)	129.0 (5.08)	122.0 (4.80)	146.0 (5.75)	31.0 (1.22)	31.0 (1.22)	14.7 (32.3)	16.9 (37.2)	14.2 (31.2)
R4060	181.0 (7.13)	135.0 (5.31)	128.0 (5.04)	151.0 (5.94)	36.0 (1.42)	36.0 (1.42)	15.2 (33.4)	17.4 (38.3)	14.7 (32.3)
S4016	151.0 (5.94)	104.0 (4.09)	98.0 (3.86)	121.0 (4.76)	0	0	12.3 (27.0)	14.5 (31.9)	11.8 (26.0)
S4023	158.0 (6.22)	112.0 (4.41)	105.0 (4.13)	129.0 (5.08)	8.0 (0.31)	8.0 (0.31)	13.0 (28.6)	15.2 (33.4)	12.5 (27.5)
S4027	163.0 (6.42)	117.0 (4.61)	110.0 (4.33)	134.0 (5.28)	13.0 (0.51)	13.0 (0.51)	13.5 (29.7)	15.7 (34.5)	13.0 (28.6)
S4032	169.0 (6.65)	123.0 (4.84)	116.0 (4.57)	139.0 (5.47)	18.0 (0.71)	18.0 (0.71)	14.0 (30.8)	16.2 (35.6)	13.5 (29.7)
S4037	175.0 (6.89)	129.0 (5.08)	122.0 (4.80)	145.0 (5.71)	24.0 (0.94)	24.0 (0.94)	14.5 (31.9)	16.7 (36.7)	14.0 (30.8)
S4042	181.0 (7.13)	135.0 (5.31)	128.0 (5.04)	151.0 (5.94)	30.0 (1.18)	30.0 (1.18)	15.0 (33.0)	17.2 (37.8)	14.5 (31.9)

\*Not / Note :

Ağırlıklar yaklaşık değerlerdir.

İkili pompa ağırlığı = (ön pompa + arka pompa) ağırlığı

Dual pompa ağırlığı = (ön pompa + arka pompa) ağırlığı – 4.5 kg (10 lb)

*Weights are approximate.*

*Double pump weight = (front + rear) weights*

*Dual pump weight = (front + rear) weights – 4.5 kg (10 lb)*

## QR4 SERİSİ / QR4 SERIES

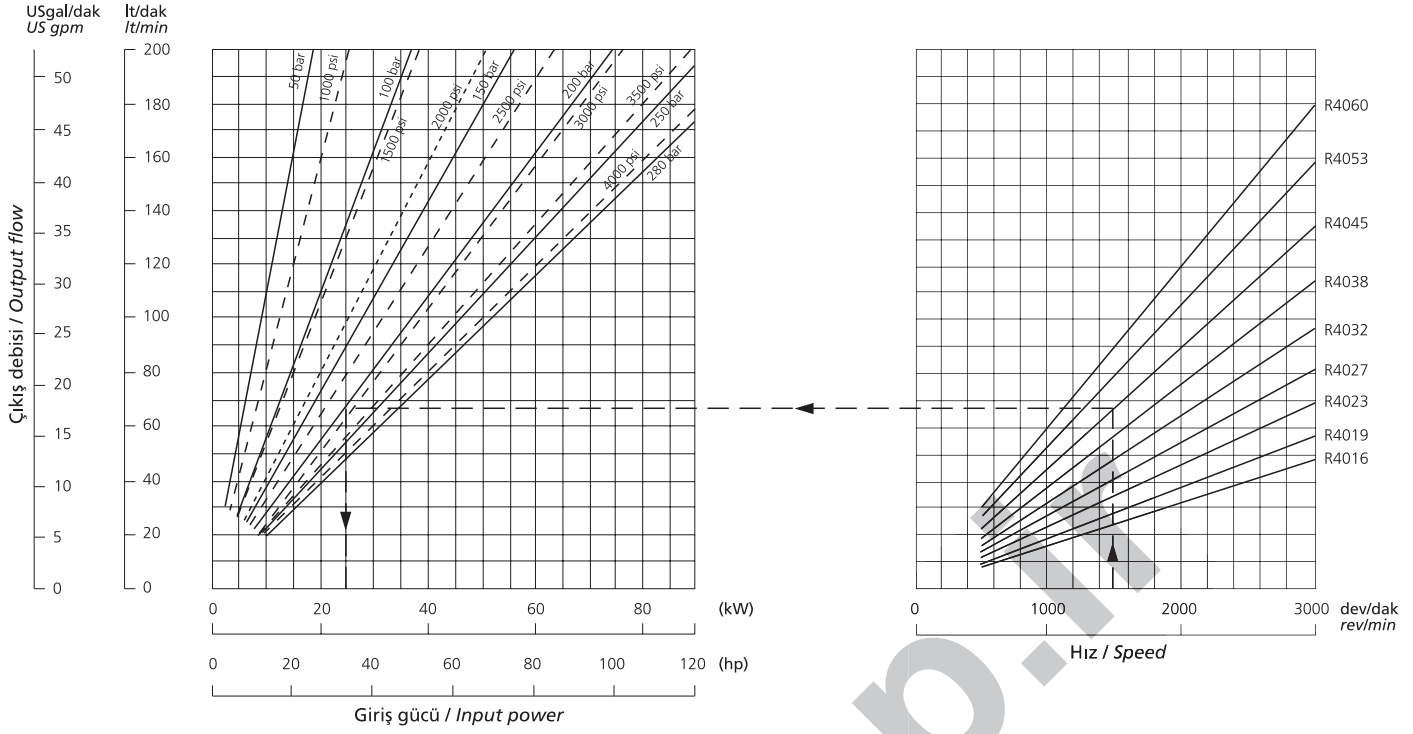

ÇIKIŞ DEBİLERİ teorik değerlerdir. Genelde volümetrik verim %95'ten fazladır.

GİRİŞ GÜÇLERİ gerçek değerlerdir. Ortalama verim hesaba katılmıştır. Çıkış basıncı 50 bar'dan daha az olursa Hema Endüstri A.Ş.'ye danışılmalıdır.

Örnek: R4045 pompası 1500 dev/dak'da, 67.5 lt/dak (17.8 USgal/dak) debi sağlar ve 200bar (2900 psi) çıkış basıncında çalıştırmak için 25 kW (33.5 hp) güç gerekir.

OUTPUT FLOWS are theoretical. Generally volumetric efficiencies are in excess of 95%

INPUT POWERS are actual, taking into account average efficiencies. Please consult Hema Endüstri A.S. when output pressure is less than 50 bar.

Example: R4045 at 1500 rev/min gives output flow of 67.5 l/min (17.8 US gal/min) and requires 25 kW (33.5 hp) to drive it at 200 bar (2900 psi).

## QS4 SERİSİ / QS4 SERIES

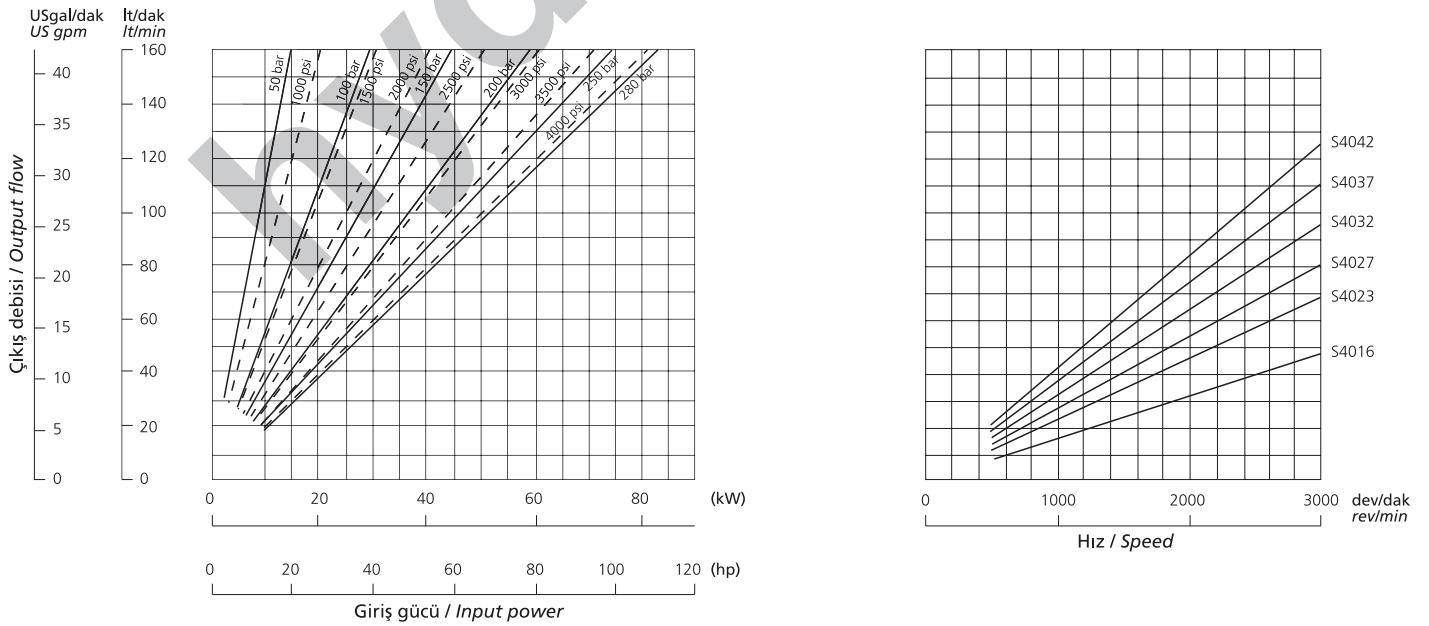

Eğriler 50°C (120°F)'de 23 cSt (110 SSU) yağ kullanılarak ortalama pompalar için çizilmiştir.

Curves drawn for average pumps at 50°C (120°F) - fluid viscosity 23 cSt (110 SSU).

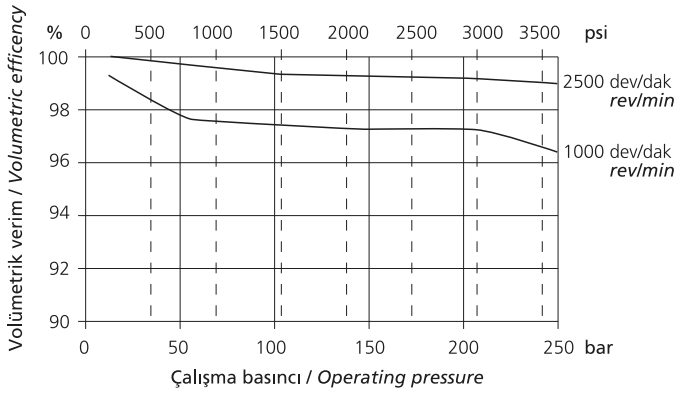
**POMPA VERİMİ / PUMP EFFICIENCIES**

Bütün Q serisi pompalar çok yüksek verimlerde çalışır. Yandaki grafik 1000 ve 2500 dev/dak'da QS4 pompasının volümetrik verim eğrilerini gösterir.

All Q series pumps share very high efficiencies. The graph shows typical QS4 volumetric efficiency curves at 1000 and 2500 revl/min.

**GÜRÜLTÜ SEVİYESİ / NOISE LEVELS**

6. sayfada belirtildiği gibi Q serisi pompaların geliştirilmesindeki en önemli faktör gürültü seviyesinin düşük olmasıdır. QR4 ve QS4 serisi pompaların, ISO 9614-4'e göre elde edilen, pompadan 1 metre uzaklıktaki ses basıncı seviyelerinin grafikleri aşağıda gösterilmiştir.

As described on page 6, the reduction of noise levels was a major factor

in the development of the Q Series Pumps. The following graphs show

QR4 and QS4 sound pressure levels at one meter from the pump

obtained in accordance with ISO 9614-4.

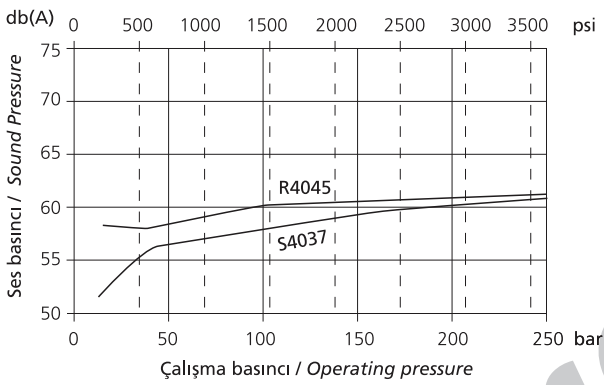
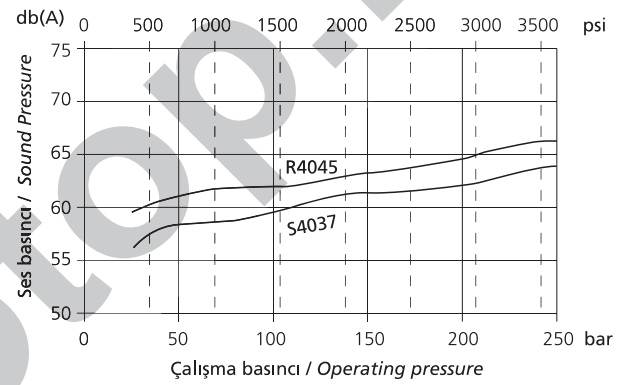
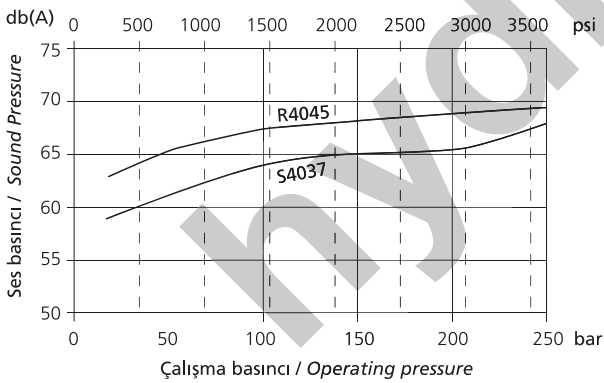
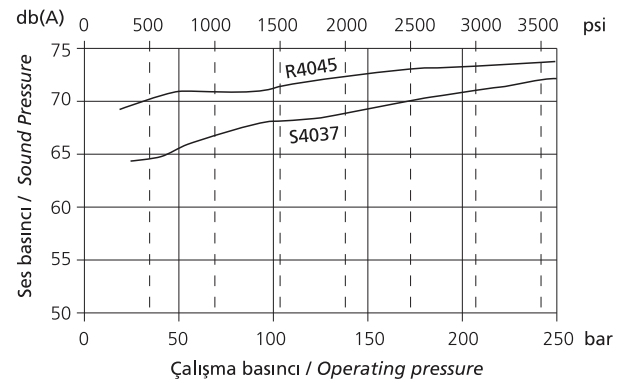
**1000 dev/dak'daki ses basıncı / Sound Pressure at 1000 rpm**

**1500 dev/dak'daki ses basıncı / Sound Pressure at 1500 rpm**

**1800 dev/dak'daki ses basıncı / Sound Pressure at 1800 rpm**

**2500 dev/dak'daki ses basıncı / Sound Pressure at 2500 rpm**

**EYLEMSİZLİK MOMENTİ / MOMENTS OF INERTIA**
**QR4 SERİSİ / QR4 SERIES**

POMPA TİPİ / PUMP SIZE		R4016	R4019	R4023	R4027	R4032	R4038	R4045	R4053	R4060
Eylemsizlik momenti Moment of Inertia	kg cm <sup>2</sup> (lb in <sup>2</sup> )	1.42 (0.48)	1.61 (0.55)	1.70 (0.58)	1.86 (0.63)	2.06 (0.70)	2.30 (0.78)	2.59 (0.88)	2.91 (0.99)	3.19 (1.09)

**QS4 SERİSİ / QS4 SERIES**

POMPA TİPİ / PUMP SIZE		SR4016	S4023	S4027	S4032	S4037	S4042
Eylemsizlik momenti Moment of Inertia	kg cm <sup>2</sup> (lb in <sup>2</sup> )	2.05 (0.70)	2.41 (0.82)	2.63 (0.90)	2.91 (0.99)	3.18 (1.08)	3.46 (1.18)

ŞAFT KEÇELERİ / SHAFT SEALS

Kod **A** Dıştan tahrikler için şaft keçesi ve toz keçesi  
Code Shaft seal and wiper for external drives

Örnek : R1 **A** 4016A11A1D1AA  
Example :

Kod **C** Tork dönüştürücüsü ve dişli kutusu ile tahrik için kaçak kontrol delikli toz keçesi-keçe ve şaft keçesi.  
Code Shaft seal, wiper and seal with tell-tale hole for torque converter and gearbox drives. The tell-tale hole indicates leakage before mixing of fluids can occur.

Örnek : R1 **C** 4016A11A1D1AA  
Example :

TAHRİK MİLLERİ / DRIVE SHAFTS

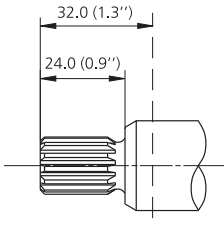
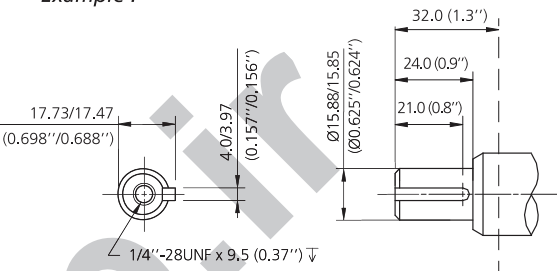
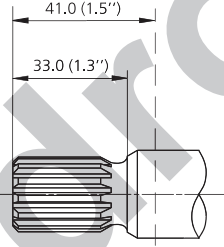
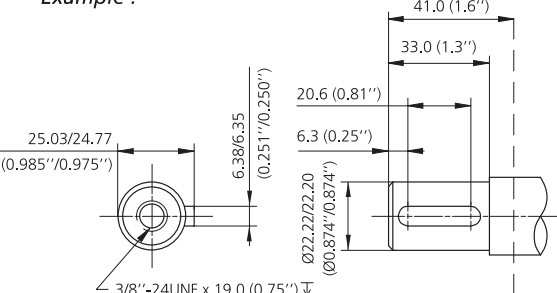
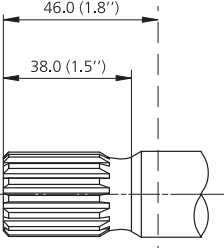
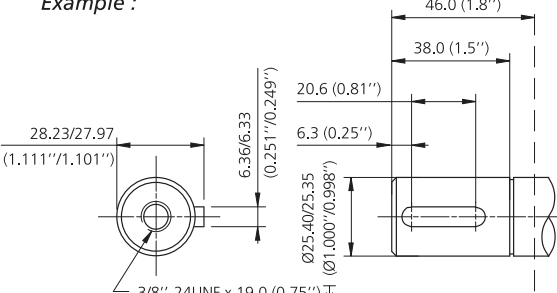
<p>Kod <b>A</b> SAE 16-4 (A) 5/8" spline Code Örnek : R1A4016 <b>A</b> 11A1D1AA Example</p> <p>Evolute spline / Involute spline 9 Diş / 9 Teeth 16/32 DP Diş dibi düz / Flot root Yanaktan alıştırılmış / Side fit 30° kavrama açısı / 30° pressure angle Diş üstü çapı / Major Dia: 15.44/15.34 (0.608"/0.604")</p>  <p><math>p \times D = 5200</math> (bar x cm<sup>3</sup>/dev)* (bar x cm<sup>3</sup>/rev) <math>p \times D = 4600</math> (psi x in<sup>3</sup>/dev)* (psi x in<sup>3</sup>/rev)</p>	<p>Kod <b>E</b> SAE 16-1 (A) 5/8" paralel / parallel Code Örnek : R1A4016 <b>E</b> 11A1D1AA Example :</p>  <p><math>p \times D = 5200</math> (bar x cm<sup>3</sup>/dev)* (bar x cm<sup>3</sup>/rev) <math>p \times D = 4600</math> (psi x in<sup>3</sup>/dev)* (psi x in<sup>3</sup>/rev)</p>
<p>Kod <b>B</b> SAE 22-4 (A) 7/8" spline Code Örnek : R1A4016 <b>B</b> 11A1D1AA Example</p> <p>Evolute spline / Involute spline 13 Diş / 13 Teeth 16/32 DP Diş dibi düz / Flot root Yanaktan alıştırılmış / Side fit 30° kavrama açısı / 30° pressure angle Diş üstü çapı / Major Dia: 21.79/21.69 (0.858"/0.854")</p>  <p><math>p \times D = 14226</math> (bar x cm<sup>3</sup>/dev)* (bar x cm<sup>3</sup>/rev) <math>p \times D = 12590</math> (psi x in<sup>3</sup>/dev)* (psi x in<sup>3</sup>/rev)</p>	<p>Kod <b>F</b> SAE 22-1 (B) 7/8" paralel / parallel Code Örnek : R1A4016 <b>F</b> 11A1D1AA Example :</p>  <p><math>p \times D = 14226</math> (bar x cm<sup>3</sup>/dev)* (bar x cm<sup>3</sup>/rev) <math>p \times D = 12590</math> (psi x in<sup>3</sup>/dev)* (psi x in<sup>3</sup>/rev)</p>
<p>Kod <b>Q</b> SAE 25-4 (BB) 1" spline Code Örnek : R1A4016 <b>Q</b> 11A1D1AA Example</p> <p>Evolute spline / Involute spline 15 Diş / 15 Teeth 16/32 DP Diş dibi düz / Flot root Yanaktan alıştırılmış / Side fit 30° kavrama açısı / 30° pressure angle Diş üstü çapı / Major Dia: 24.97/24.87 (0.983"/0.979")</p>  <p><math>p \times D = 22450</math> (bar x cm<sup>3</sup>/dev)* (bar x cm<sup>3</sup>/rev) <math>p \times D = 19869</math> (psi x in<sup>3</sup>/dev)* (psi x in<sup>3</sup>/rev)</p>	<p>Kod <b>H</b> SAE 25-1 (BB) 1" paralel / parallel Code Örnek : R1A4016 <b>H</b> 11A1D1AA Example :</p>  <p><math>p \times D = 22450</math> (bar x cm<sup>3</sup>/dev)* (bar x cm<sup>3</sup>/rev) <math>p \times D = 19869</math> (psi x in<sup>3</sup>/dev)* (psi x in<sup>3</sup>/rev)</p>

\* p=basınç, D=iletim hacmi. Belirtilen değerler aşılmamalıdır.  
Not: Çoklu pompalarda, p x D değerlerinin toplamı belirtilen değeri aşmamalıdır. Sayfa 39'a bakınız.

\* p = pressure, D = displacement. The stated values must not be exceeded.  
Note: For multiple pumps the sum of the p x D values must not exceed the stated value. See Page 39.

Kod  
Code

SAE 82-2 (A - 2 civatalı / bolt)

Örnek : R1A4016A 1 1A1D1AA

Example

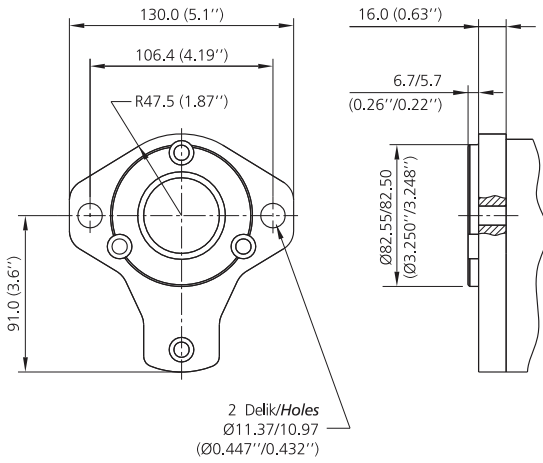
Kod  
Code

SAE 101-2 (B - 2 civatalı / bolt)

Örnek : R1A4016B 2 1A1D1AA

Example

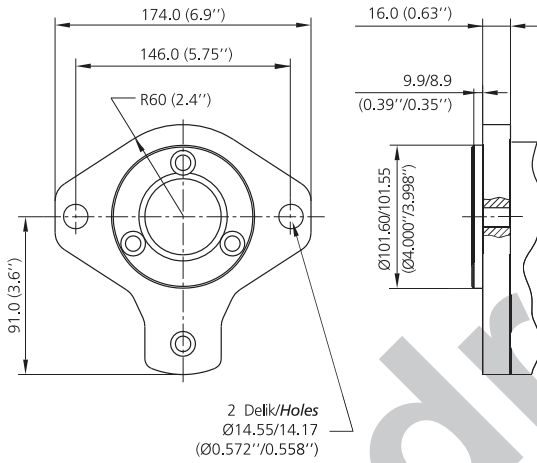
Kod  
Code

SAE 101-4 (B - 4 civatalı / bolt)

Örnek : R1A4016A 3 1A1D1AA

Example

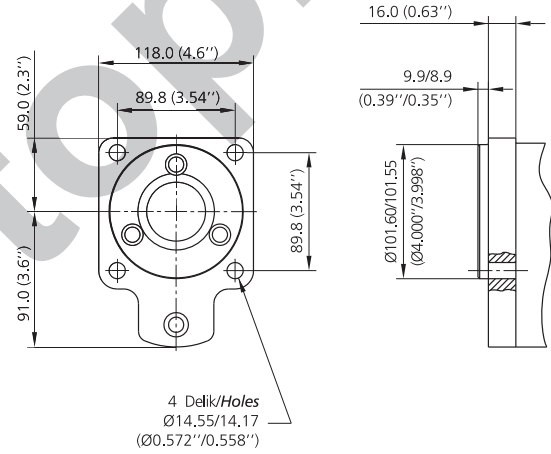
Kod  
Code

SAE 127-2 (C - 2 civatalı / bolt)

Örnek : R1A4016A 4 1A1D1AA

Example

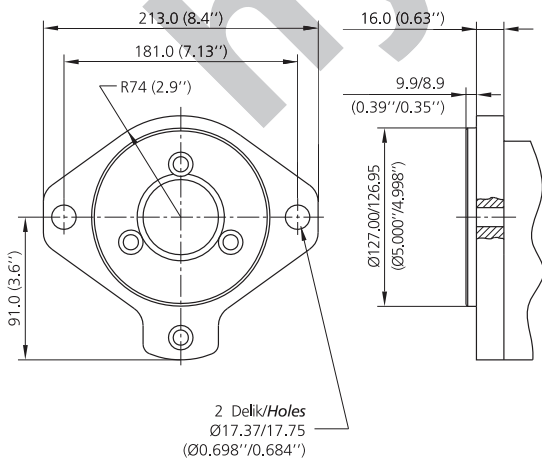
Kod  
Code

SAE 127-4 (C - 4 civatalı / bolt)

Örnek : R1A4016A 5 1A1D1AA

Example

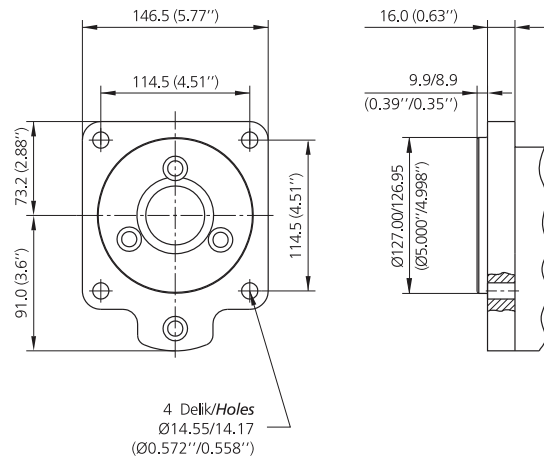

## POMPA SAYISI VE GİRİŞ DELİĞİ KONUMLARI / NUMBER OF PUMP SECTIONS AND INLET PORT POSITIONS

Kod A  
Code

Şekil / Fig 1

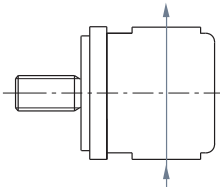
Kod C  
Code

Şekil / Fig 2

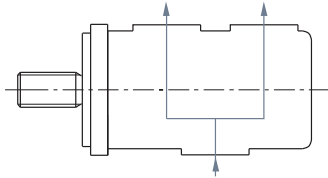
Kod B  
Code

Şekil / Fig 3

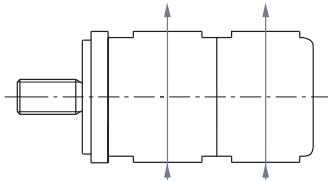
Kod A  
Code

Şekil / Fig 4

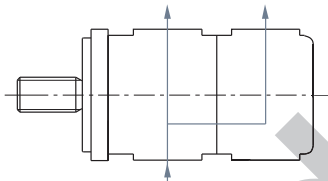

## TEKLİ POMPA / SINGLE PUMP

Örnek / Example

**R1A4027B51A1F1BC**

1 Pompa sayısı / Number of pump sections

A Giriş deliği konumu - şekil-1'e bakın / Inlet port position - see fig 1

1 Giriş deliği tipi - tablo 1'e bakın / Inlet port type - see table 1

F Giriş deliği ölçüleri - tablo 1'e bakın / Inlet port size - see table 1

1 Çıkış deliği tipi - tablo 2'ye bakın / Outlet port type - see table 2

B Çıkış deliği ölçüleri - tablo 2'ye bakın / Outlet port size - see table 2

C Dönüş yönü - Tahrik mili tarafında bakışa göre / Rotation - viewed from shaft

## İKİLİ VEYA DUAL POMPA / MULTI PUMP

Örnek / Example

**R1A4027S4027Q52B1H3B1F3BC**

2 Pompa sayısı / Number of pump sections

B Giriş deliği konumu - şekil-2, 3 veya 4'e bakın / Inlet port position - see figs 2, 3 or 4

1 1. Giriş deliği tipi - tablo 1'e bakın / 1st Inlet port type - see table 1

H 1. Giriş deliği ölçüleri - tablo 1'e bakın / 1st Inlet port size - see table 1

3 1. Çıkış deliği tipi - tablo 2'ye bakın / 1st Outlet port type - see table 2

B 1. Çıkış deliği ölçüleri - tablo 2'ye bakın / 1st Outlet port size - see table 2

1 2. Giriş deliği tipi - tablo 1'e bakın / 2nd Inlet port type - see table 1

F 2. Giriş deliği ölçüleri - tablo 1'e bakın / 2nd Inlet port size - see table 1

3 2. Çıkış deliği tipi - tablo 2'ye bakın / 2nd Outlet port type - see table 2

B 2. Çıkış deliği ölçüleri - tablo 2'ye bakın / 2nd Outlet port size - see table 2

C Dönüş yönü - Tahrik mili tarafında bakışa göre / Rotation - viewed from shaft

## ÇOKLU POMPALAR / MULTIPLE PUMPS

Hema Endüstri A.Ş.'ye başvurunuz. / Please consult Hema Endüstri A.S.

## SAE FLANŞLI DELİK ÖLÇÜLERİ / SAE FLANGE PORT DETAILS

SAE kod 61

SAE code 61

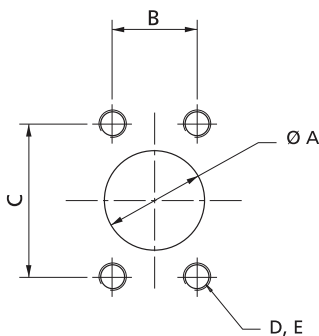

12.7	17.48	38.10	M8 x 1.25	24.0
(0.500)	(0.688)	(1.500)	5/6"-18 UNC	(0.95)
19.1	22.23	47.63	M10 x 1.5	22.4
(0.750)	(0.875)	(1.875)	3/8"-16 UNC	(0.88)
25.4	26.19	52.37	M10 x 1.5	22.4
(1.000)	(1.031)	(2.062)	3/8"-16 UNC	(0.88)
31.18	30.18	58.72	M10 x 1.5	28.4
(1.250)	(1.188)	(2.312)	7/16"-14 UNC	(1.12)
38.1	35.71	69.85	M12 x 1.75	26.9
(1.500)	(1.406)	(2.750)	1/2"-13 UNC	(1.06)
50.8	42.88	77.77	M12 x 1.75	26.9
(2.000)	(1.688)	(3.062)	1/2"-13 UNC	(1.06)

**TABLO 1 : GİRİŞ DELİĞİ OPSİYONLARI / TABLE 1 - INLET PORT OPTIONS**

Delik Tipi Port Type	TEKLİ POMPA GİRİŞ DELİĞİ OPSİYONLARI SINGLE PUMP INLET PORT OPTIONS										ORTAK GİRİŞ DELİĞİ OPSİYONLARI COMMON INLET PORT OPTIONS				İKİLİ GİRİŞ DELİĞİ OPSİYONLARI DUAL INLET PORT OPTIONS										
Delik Tipi Kodu Port Type Code	3		1			2			4		1				2				1			2			
Delik Tipi Port Type	BSPP		SAE Flanş Metrik SAE Flange Metric			SAE Flanş UNC SAE Flange UNC			UNF O-ring		SAE Flanş Metrik SAE Flange Metric				SAE Flanş UNC SAE Flange UNC				SAE Flanş Metrik SAE Flange Metric			SAE Flanş UNC SAE Flange UNC			
Delik Ölçü Kodu Port Size Code	D	F	D	F	H	D	F	H	G	J	D	F	H	K	D	F	H	K	F	H	K	F	H	K	
Delik Ölçüsü Port Size	1	1.1/4	1	1.1/4	1.1/2	1	1.1/4	1.1/2	1.5/16	1.5/8	1	1.1/4	1.1/2	2	1	1.1/4	1.1/2	2	1.1/4	1.1/2	2	1.1/4	1.1/2	2	
R4016	■	□	■	□	□	■	□	□	■	□	□	□	■	□	□	□	■	□	□	□	□	■	□	□	■
R4019	■	□	■	□	□	■	□	□	■	□	□	□	■	□	□	□	■	□	□	□	□	■	□	□	■
R4023	■	□	■	□	□	■	□	□	■	□	□	□	■	□	□	□	■	□	□	□	□	■	□	□	■
R4027	□	■	□	■	□	□	■	□	□	■	□	□	■	□	□	□	■	□	□	□	□	■	□	□	■
R4032	□	■	□	■	□	□	■	□	□	■	□	□	■	□	□	□	■	□	□	□	□	■	□	□	■
R4038			□	■	□	□	■	□	□	■	□	□	■	□	□	□	■	□	□	□	□	■	□	□	■
R4045			□	□	■	□	□	■			□	□	■		□	□	■		□	□	■	□	□	■	
R4053			□	□	■	□	□	■			□	□	■		□	□	■		□	□	■	□	□	■	
R4060			□	□	■	□	□	■			□	□	■		□	□	■		□	□	■	□	□	■	
S4016	■	□	■	□	□	■	□	□	■	□	□	□	■	□	□	□	■	□	□	□	□	■	□	□	■
S4023	■	□	■	□	□	■	□	□	■	□	□	□	■	□	□	□	■	□	□	□	□	■	□	□	■
S4027	□	■	□	■	□	□	■	□	□	■	□	□	■	□	□	□	■	□	□	□	□	■	□	□	■
S4032	□	■	□	■	□	□	■	□	□	■	□	□	■	□	□	□	■	□	□	□	□	■	□	□	■
S4037	□	■	□	■	□	□	■	□	□	■	□	□	■	□	□	□	■	□	□	□	□	■	□	□	■
S4042			□	□	■	□	□	■			□	□	■		□	□	■		□	□	■	□	□	■	

■ Tercih edilen delik tipi Preferred port size □ Tercih edilmeyen delik tipi Non-preferred port size

Not / Note :

Tek girişli çoklu pompaların model numarasını oluştururken, "2. giriş deliği tipi" için "0" ve "2. giriş deliği ölçüsü" için "X" kodunu kullanınız.

When coding, for single inlet multiple pumps, use '0' in 2nd inlet port type' and 'X' in '2nd inlet port size' in he model number.

**TABLO 2 : ÇIKIŞ DELİĞİ OPSİYONLARI / TABLE 2 - OUTLET PORT OPTIONS**

Delik Tipi Kodu Port Type Code	3				1			2			4			
Delik Tipi Port Type	BSPP				SAE Flanş Metrik SAE Flange Metric			SAE Flanş UNC SAE Flange UNC			UNF O-ring			
Delik Ölçü Kodu Port Size Code	A	B	D	F	A	B	D	A	B	D	C	E	G	J
Delik Ölçüsü Port Size	1/2	3/4	1	1.1/4	1/2	3/4	1	1/2	3/4	1	7/8	1.1/16	1.5/16	1.5/8
R4016	■	□	□	□	■	□	□	■	□	□	■	□	□	□
R4019	■	□	□	□	■	□	□	■	□	□	□	□	□	□
R4023	■	□	□	□	■	□	□	■	□	□	□	□	□	□
R4027	□	■	□	□	□	■	□	□	■	□	□	■	□	□
R4032	□	■	□	□	□	■	□	□	■	□	□	■	□	□
R4038	□	■	□	□	□	■	□	□	■	□	□	■	□	□
R4045	□	■	□	□	□	■	□	□	■	□	□	■	□	□
R4053	□	■	□	□	□	■	□	□	■	□	□	■	□	□
R4060	□	■	□	□	□	■	□	□	■	□	□	■	□	□
S4016	■	□	□	□	■	□	□	■	□	□	■	□	□	□
S4023	■	□	□	□	■	□	□	■	□	□	■	□	□	□
S4027	■	□	□	□	□	■	□	□	■	□	□	□	□	□
S4032	□	■	□	□	□	■	□	□	■	□	□	□	□	□
S4037	□	■	□	□	□	■	□	□	■	□	□	□	□	□
S4042	□	■	□	□	□	■	□	□	■	□	□	□	□	□

■ Tercih edilen delik tipi Preferred port size □ Tercih edilmeyen delik tipi Non-preferred port size

## Not / Note

Aşağıdaki çizimler saat yönü döneli pompalarıdır. Saat yönünün tersi döneli pompalarda giriş ve çıkış delikleri yer değişir. (Dönüş yönü tayini, tahrik mili tarafında bakışa göredir.)

Drawings show clockwise rotation pumps. For anti-clockwise rotation pumps reverse the inlet and outlet port positions. (Rotation convention – view from pump shaft end).

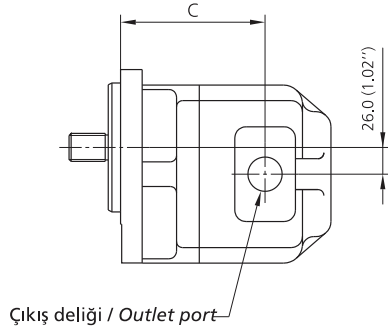
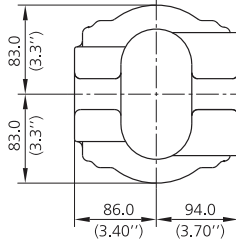
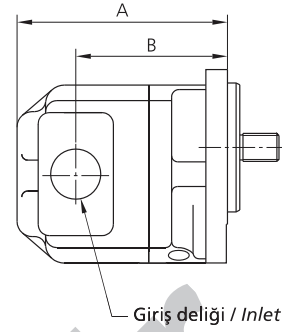
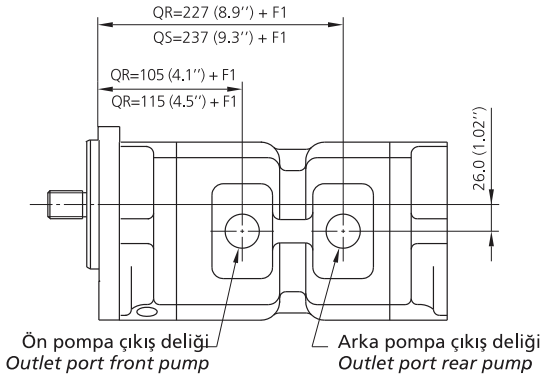
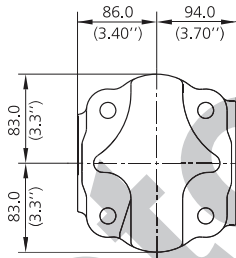
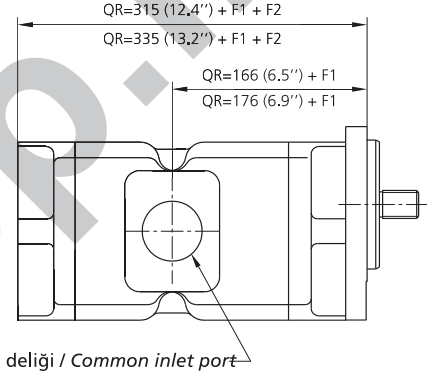
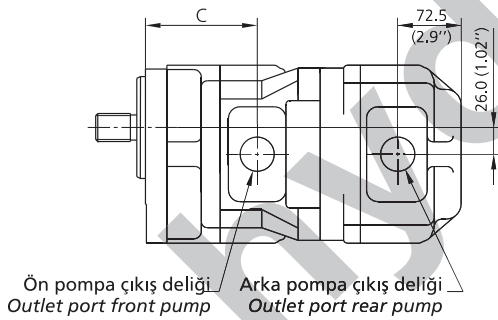
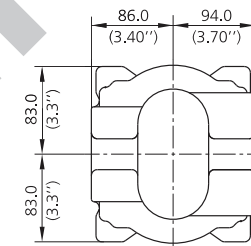
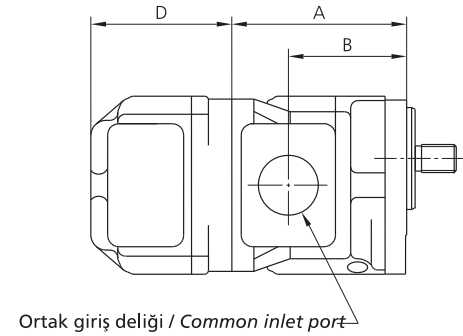
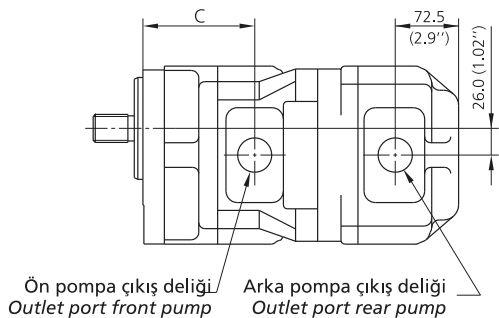
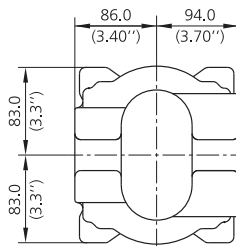
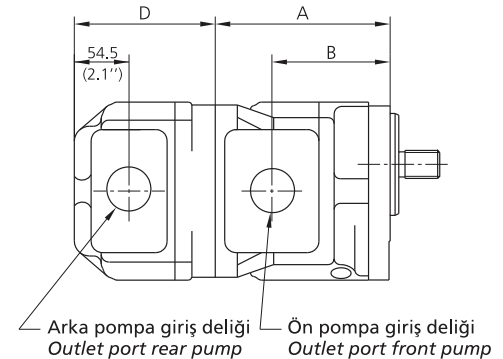
**TEKLİ POMPALAR - standart delikler**  
**SINGLE PUMPS - standard ports**

**Kod A**  
**Code**

**Örnek : R1A5045B21 A 1H1DC**  
**Example :**

**DUAL POMPALAR - 1 giriş / 2 çıkış**  
**DUAL PUMPS - 1 inlet / 2 outlets**

**Kod C**  
**Code**

**Örnek : R1A5045R5045B22 C 1L1D0X1DC**  
**Example :**

**İKİLİ POMPALAR - 1 giriş / 2 çıkış**  
**DOUBLE PUMPS - 1 inlet / 2 outlets**

**Kod A**  
**Code**

**Örnek : R1A5045R5045B22 A 1L1D0X1DC**  
**Example :**

**İKİLİ POMPALAR - 2 giriş / 2 çıkış**  
**DOUBLE PUMPS - 2 inlets / 2 outlets**

**Kod B**  
**Code**

**Örnek : R1A5045R5045B22 B 1H1D1H1DC**  
**Example :**

**ÜÇLÜ VE DÖRTLÜ POMPALAR - 39. ve 40. sayfalara bakınız.**  
**TRIPLE AND QUADRUPLE PUMPS - See pages 39 and 40.**



POMPA PUMP	A mm (in)	B mm (in)	C mm (in)	D mm (in)	F1 Ön Pompa Front Pump mm (in)	F2 Arka Pompa Rear Pump mm (in)	AĞIRLIK WEIGHT kg (lb)		
							Tekli* Single	Ön* Front	Arka* Rear
R5045	178.0 (7.00)	123.0 (4.84)	105.0 (4.13)	144.0 (5.67)	0	0	19.7 (43.3)	23.2 (51.9)	17.2 (37.8)
R5053	82.0 (7.16)	127.0 (5.00)	109.0 (4.29)	148.0 (5.83)	4.0 (0.16)	4.0 (0.16)	20.8 (45.8)	24.3 (53.5)	18.3 (40.3)
R5063	187.0 (7.36)	133.0 (5.24)	115.0 (4.53)	154.0 (6.06)	10.0 (0.39)	10.0 (0.39)	21.7 (47.7)	25.2 (55.4)	19.2 (42.2)
R5073	193.0 (7.60)	138.0 (5.43)	120.0 (4.72)	159.0 (6.26)	15.0 (0.59)	15.0 (0.59)	22.5 (49.5)	26.0 (57.2)	20.0 (44.0)
R5085	199.0 (7.83)	145.0 (5.71)	127.0 (5.00)	166.0 (6.53)	22.0 (0.87)	22.0 (0.87)	23.5 (51.7)	27.0 (59.4)	21.0 (46.2)
R5100	207.0 (8.15)	153.0 (6.02)	135.0 (5.31)	174.0 (6.85)	30.0 (1.18)	30.0 (1.18)	25.0 (55.0)	28.5 (62.7)	22.5 (49.5)
R5120	218.0 (8.58)	164.0 (6.46)	146.0 (5.75)	185.0 (7.28)	40.0 (1.57)	40.0 (1.57)	26.5 (58.3)	30.0 (66.0)	24.0 (52.8)
S5045	188.0 (7.40)	133.0 (5.24)	115.0 (4.53)	154.0 (6.06)	0	0	24.0 (53.0)	27.5 (60.5)	21.5 (47.3)
S5051	192.0 (7.56)	138.0 (5.43)	120.0 (4.72)	159.0 (6.26)	5.0 (0.20)	5.0 (0.20)	24.5 (54.0)	28.0 (61.6)	22.0 (48.4)
S5060	199.0 (7.83)	145.0 (5.71)	127.0 (5.00)	166.0 (6.53)	12.0 (0.47)	12.0 (0.47)	25.0 (55.0)	28.5 (62.7)	22.5 (49.5)
S5070	207.0 (8.15)	152.0 (5.98)	134.0 (5.28)	173.0 (6.81)	20.0 (0.79)	20.0 (0.79)	25.5 (56.0)	29.0 (63.8)	23.0 (50.6)
S5085	218.0 (8.58)	164.0 (6.50)	146.0 (5.75)	185.0 (7.28)	31.0 (1.22)	31.0 (1.22)	26.8 (59.0)	30.3 (66.7)	24.3 (50.0)

\*Not / Note :

Ağırlıklar yaklaşık değerlerdir.

İkili pompa ağırlığı = (ön pompa + arka pompa) ağırlığı

Dual pompa ağırlığı = (ön pompa + arka pompa) ağırlığı – 6 kg (13 lb)

*Weights are approximate.*

*Double pump weight = (front + rear) weights*

*Dual pump weight = (front + rear) weights – 6 kg (13 lb)*

## QR5 SERİSİ / QR5 SERIES

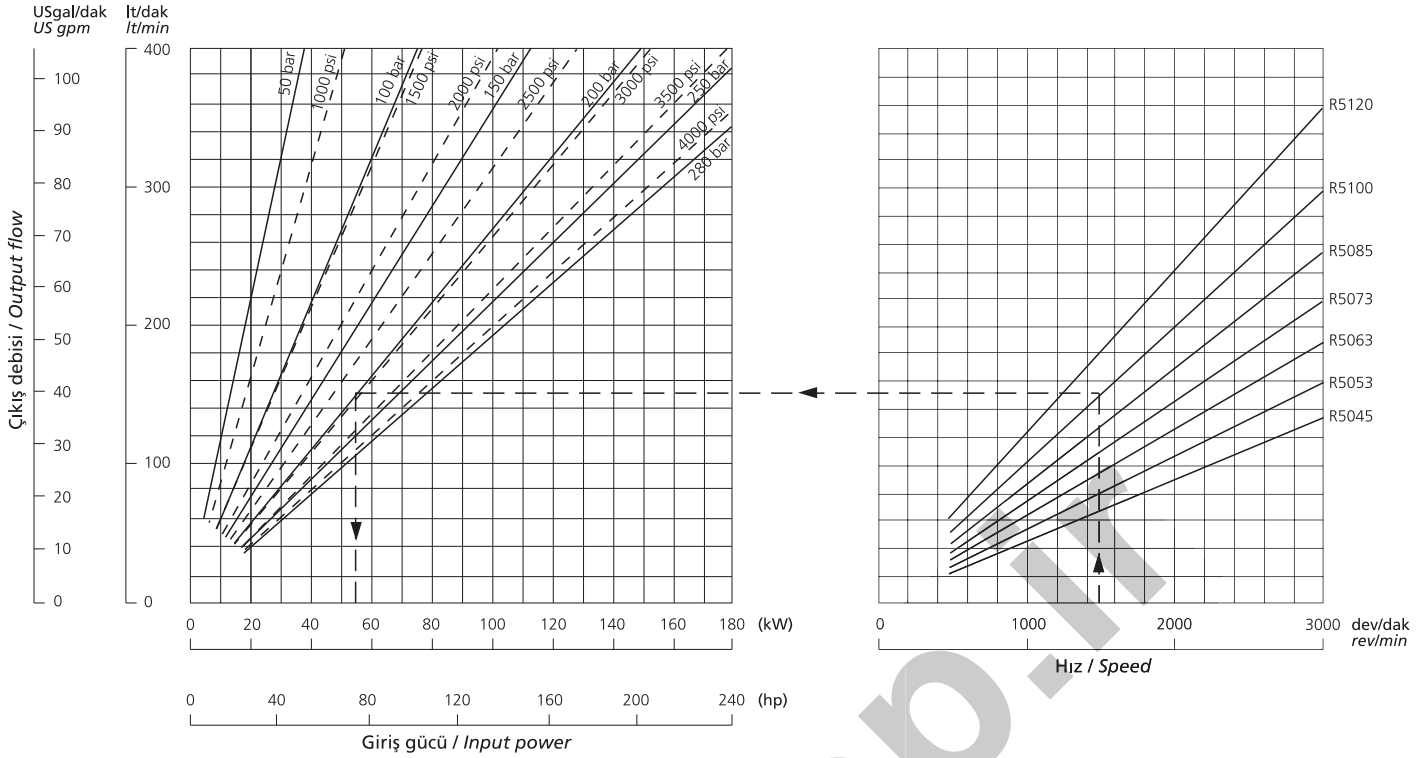

ÇIKIŞ DEBİLERİ teorik değerlerdir. Genelde volümetrik verim %95'tan fazladır.

GİRİŞ GÜÇLERİ gerçek değerlerdir. Ortalama verim hesaba katılmıştır. Çıkış basıncı 50 bar'dan daha az olursa Hema Endüstri A.Ş.'ye danışılmalıdır.

Örnek: R5100 pompası 1500 dev/dak'da, 150 lt/dak (39.6 USgal/dak) debi sağlar ve 200 bar (2900 psi) çıkış basıncında çalıştırmak için 56 kW (75 hp) güç gerekir.

OUTPUT FLOWS are theoretical. Generally volumetric efficiencies are in excess of 95%

INPUT POWERS are actual, taking into account average efficiencies. Please consult Hema Endüstri A.S. when output pressure is less than 50 bar.

Example :R5100 at 1500 rev/min gives output flow of 150 l/min (39.6 US gall/min) and requires 56 kW (75 hp) to drive it at 200 bar (2900 psi).

## QS5 SERİSİ / QS5 SERIES

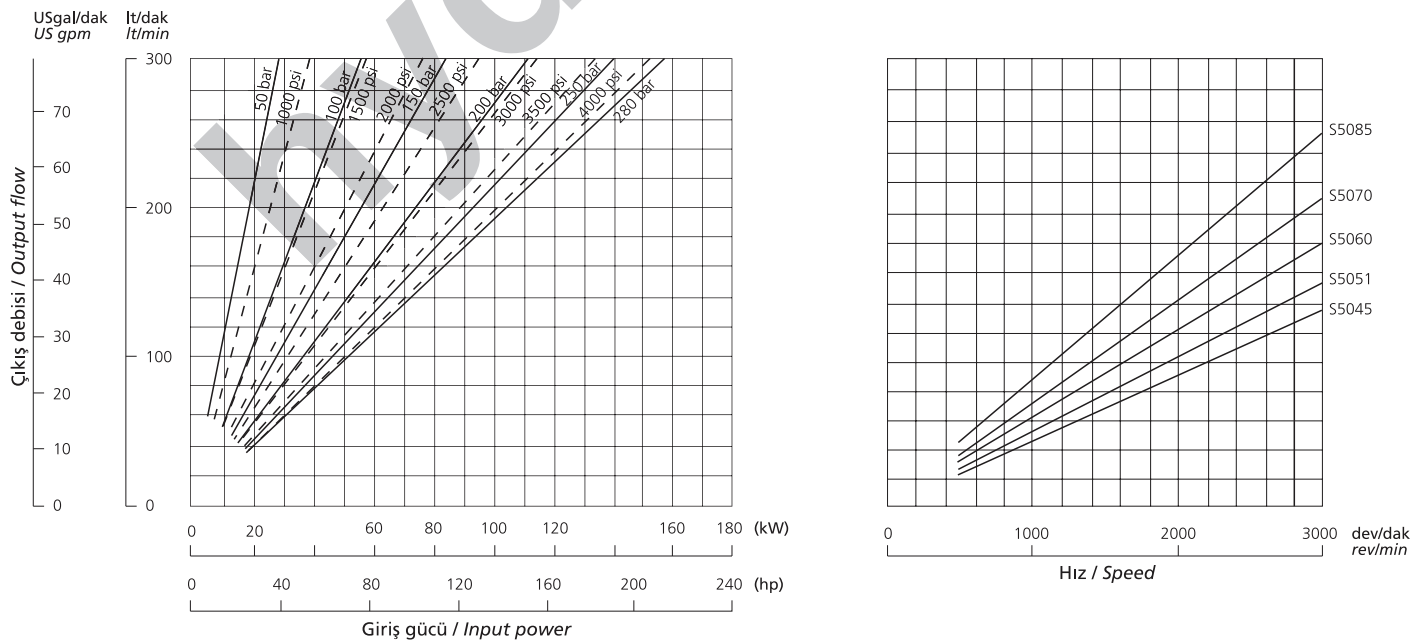

Eğriler 50°C (120°F)'de 23 cSt (110 SSU) yağ kullanılarak ortalama pompalar için çizilmiştir.

Curves drawn for average pumps at 50°C (120°F) - fluid viscosity 23 cSt (110 SSU).

## POMPA VERİMİ / PUMP EFFICIENCIES

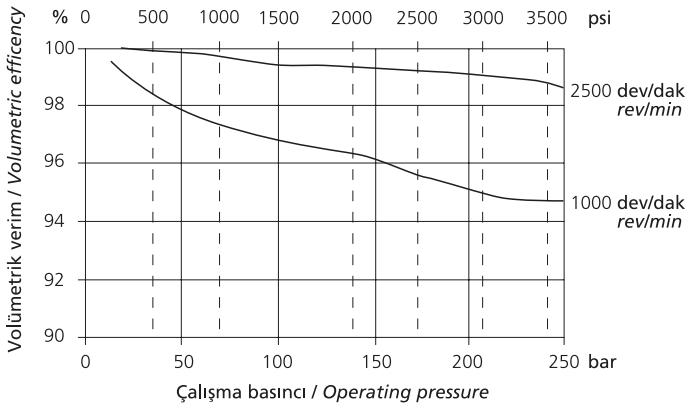

Bütün Q serisi pompalar çok yüksek verimlerde çalışır. Yandaki grafik 1000 ve 2500 dev/dak'da QS5 pompasının volümetrik verim eğrilerini gösterir.

All Q series pumps share very high efficiencies. The graph shows typical QS5 volumetric efficiency curves at 1000 and 2500 rev/min.

## GÜRÜLTÜ SEVİYESİ / NOISE LEVELS

6. sayfada belirtildiği gibi Q serisi pompaların geliştirilmesindeki en önemli faktör gürültü seviyesinin düşük olmasıdır. QR5 ve QS5 serisi pompaların, ISO 9614-4'e göre elde edilen, pompadan 1 metre uzaklıktaki ses basıncı seviyelerinin grafikleri aşağıda gösterilmiştir.

As described on page 6, the reduction of noise levels was a major factor in the development of the Q Series Pumps. The following graphs show QR5 and QS5 sound pressure levels at one meter from the pump obtained in accordance with ISO 9614-4.

## 1000 dev/dak'daki ses basıncı / Sound Pressure at 1000 rpm

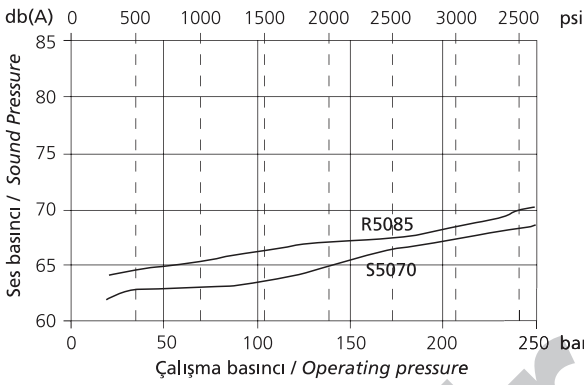

## 1500 dev/dak'daki ses basıncı / Sound Pressure at 1500 rpm

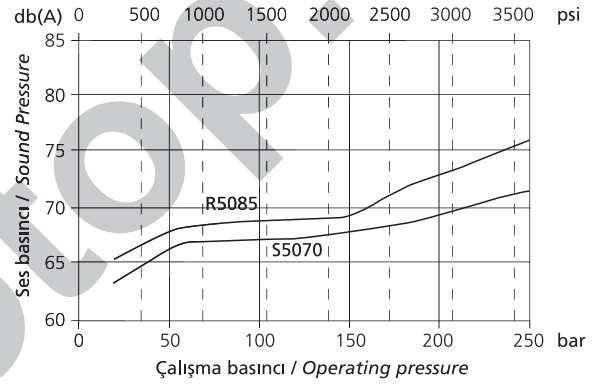

## 1800 dev/dak'daki ses basıncı / Sound Pressure at 1800 rpm

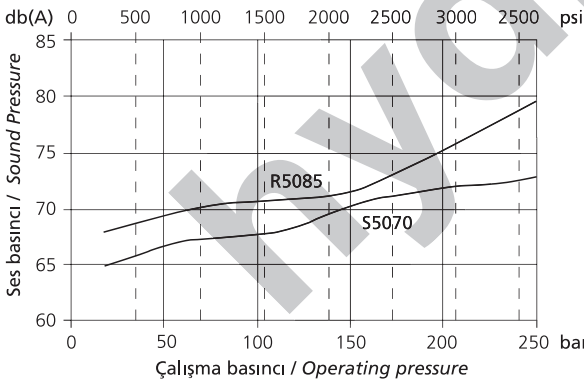

## 2500 dev/dak'daki ses basıncı / Sound Pressure at 2500 rpm

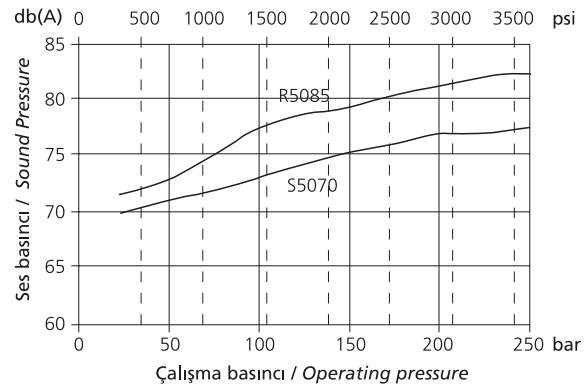

## EYLEMSİZLİK MOMENTİ / MOMENTS OF INERTIA

## QR5 SERİSİ / QR5 SERIES

POMPA TİPİ / PUMP SIZE		R5045	R5053	R5063	R5073	R5085	R5100	R5120
Eylemsizlik momenti Moment of Inertia	kg cm <sup>2</sup> (lb in <sup>2</sup> )	5.18 (1.76)	5.70 (1.94)	6.33 (2.15)	6.95 (2.38)	7.71 (2.62)	8.65 (2.94)	9.91 (3.37)

## QS5 SERİSİ / QS5 SERIES

POMPA TİPİ / PUMP SIZE		S5045	S5051	S5060	S5070	S5085	S5100
Eylemsizlik momenti Moment of Inertia	kg cm <sup>2</sup> (lb in <sup>2</sup> )	7.18 (2.44)	7.68 (2.61)	8.44 (2.87)	9.28 (3.15)	10.54 (3.58)	12.40 (5.22)

ŞAFT KEÇELERİ / SHAFT SEALS

Kod **A** Dıştan tahrikler için şaft keçesi ve toz keçesi  
Code Shaft seal and wiper for external drives

Örnek : R1 **A** 5045Q51A1H1DA  
Example :

Kod **C** Tork dönüştürücüsü ve dişli kutusu ile tahrik için kaçak kontrol delikli toz keçesi-keçe ve şaft keçesi.  
Code Shaft seal, wiper and seal with tell-tale hole for torque converter and gearbox drives. The tell-tale hole indicates leakage before mixing of fluids can occur.

Örnek : R1 **C** 5045H2A1H1DA  
Example :

TAHRİK MİLLERİ / DRIVE SHAFTS

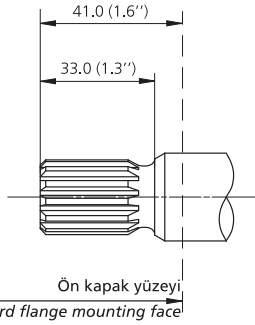
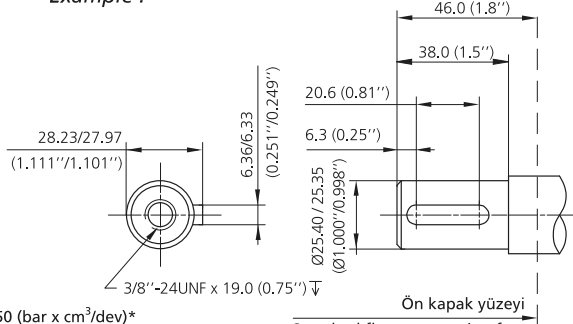
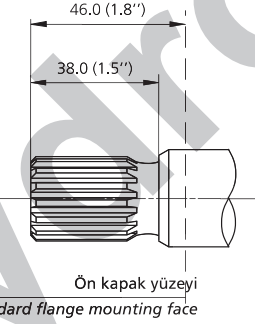
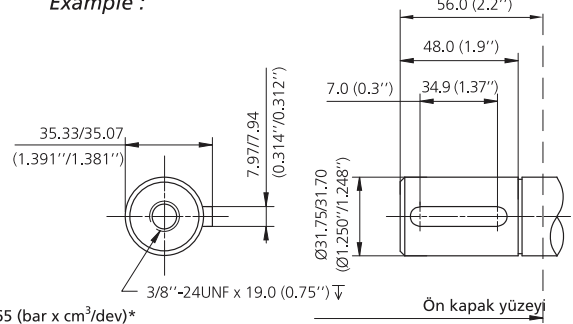
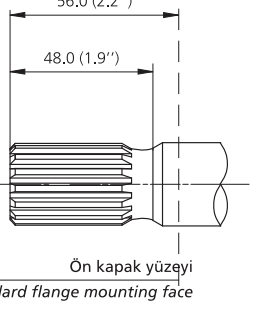
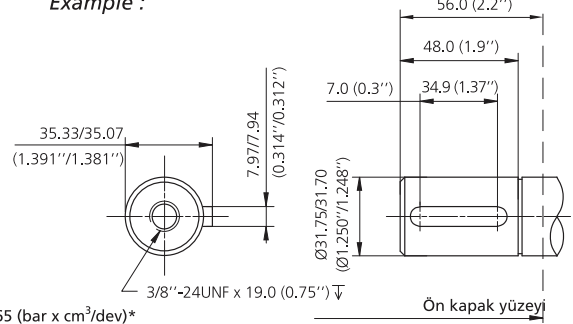
<p>Kod <b>B</b> SAE 22-4 (A) 7/8" spline Code Örnek : R1A5045 <b>B</b> 21A1H1DA Example</p> <p>Evolvent spline / Involute spline 13 Diş / 13 Teeth 16/32 DP Diş dibi düz / Flat root Yanaktan alıştırırmalı / Side fit 30° kavrama açısı / 30° pressure angle Diş üstü çapı / Major Dia: 21.79/21.69 (0.858"/0.854")</p>  <p><math>p \times D = 14226</math> (bar x cm<sup>3</sup>/dev)* (bar x cm<sup>3</sup>/rev)</p> <p><math>p \times D = 12590</math> (psi x in<sup>3</sup>/dev)* (psi x in<sup>3</sup>/rev)</p> <p>Ön kapak yüzeyi Standard flange mounting face</p>	<p>Kod <b>H</b> SAE 25-1 (BB) 1" paralel / parallel Code Örnek : R1A5045 <b>H</b> 21A1H1DA Example :</p>  <p><math>p \times D = 22450</math> (bar x cm<sup>3</sup>/dev)* (bar x cm<sup>3</sup>/rev)</p> <p><math>p \times D = 19869</math> (psi x in<sup>3</sup>/dev)* (psi x in<sup>3</sup>/rev)</p> <p>Ön kapak yüzeyi Standard flange mounting face</p>
<p>Kod <b>Q</b> SAE 25-4 (BB) 1" spline Code Örnek : R1A5045 <b>Q</b> 21A1H1DA Example</p> <p>Evolvent spline / Involute spline 15 Diş / 15 Teeth 16/32 DP Diş dibi düz / Flat root Yanaktan alıştırırmalı / Side fit 30° kavrama açısı / 30° pressure angle Diş üstü çapı / Major Dia: 24.97/24.87 (0.983"/0.979")</p>  <p><math>p \times D = 22450</math> (bar x cm<sup>3</sup>/dev)* (bar x cm<sup>3</sup>/rev)</p> <p><math>p \times D = 19869</math> (psi x in<sup>3</sup>/dev)* (psi x in<sup>3</sup>/rev)</p> <p>Ön kapak yüzeyi Standard flange mounting face</p>	<p>Kod <b>G</b> SAE 32-1 (C) 1.1/4" paralel / parallel Code Örnek : R1A5045 <b>G</b> 21A1H1DA Example :</p>  <p><math>p \times D = 45565</math> (bar x cm<sup>3</sup>/dev)* (bar x cm<sup>3</sup>/rev)</p> <p><math>p \times D = 40325</math> (psi x in<sup>3</sup>/dev)* (psi x in<sup>3</sup>/rev)</p> <p>Ön kapak yüzeyi Standard flange mounting face</p>
<p>Kod <b>C</b> SAE 32-4 (C) 1.1/4" spline Code Örnek : R1A5045 <b>C</b> 21A1H1DA Example</p> <p>Evolvent spline / Involute spline 14 Diş / 14 Teeth 12/24 DP Diş dibi düz / Flat root Yanaktan alıştırırmalı / Side fit 30° kavrama açısı / 30° pressure angle Diş üstü çapı / Major Dia: 31.22/31.12 (1.229"/1.225")</p>  <p><math>p \times D = 45565</math> (bar x cm<sup>3</sup>/dev)* (bar x cm<sup>3</sup>/rev)</p> <p><math>p \times D = 40325</math> (psi x in<sup>3</sup>/dev)* (psi x in<sup>3</sup>/rev)</p> <p>Ön kapak yüzeyi Standard flange mounting face</p>	<p>Kod <b>G</b> SAE 32-1 (C) 1.1/4" paralel / parallel Code Örnek : R1A5045 <b>G</b> 21A1H1DA Example :</p>  <p><math>p \times D = 45565</math> (bar x cm<sup>3</sup>/dev)* (bar x cm<sup>3</sup>/rev)</p> <p><math>p \times D = 40325</math> (psi x in<sup>3</sup>/dev)* (psi x in<sup>3</sup>/rev)</p> <p>Ön kapak yüzeyi Standard flange mounting face</p>

\* p=basınç, D=iletim hacmi. Belirtilen değerler aşılmamalıdır.  
Not: Çoklu pompalarda, p x D değerlerinin toplamı belirtilen değeri aşmamalıdır. Sayfa 39'a bakınız.

\* p = pressure, D = displacement. The stated values must not be exceeded.  
Note: For multiple pumps the sum of the p x D values must not exceed the stated value. See Page 39.

Kod  
Code

SAE 101-2 (B - 2 Civatalı/bolt)

Örnek : R1A5045B 2 1A1H1DA

Example

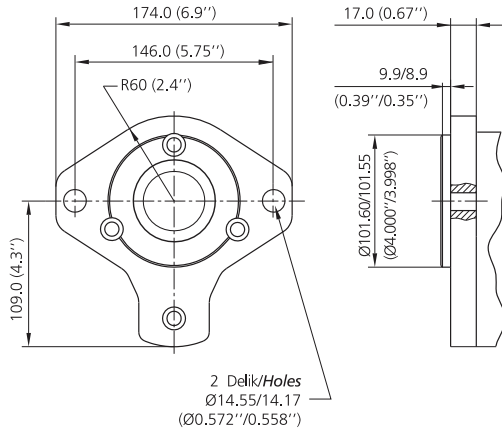
Kod  
Code

SAE 101-4 (B - 4 Civatalı/bolt)

Örnek : R1A5045AB 3 1A1H1DA

Example

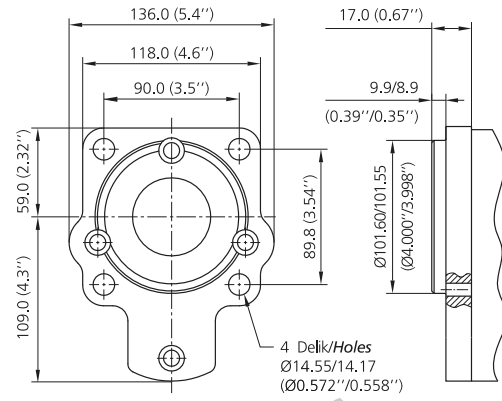
Kod  
Code

SAE 127-2 (C - 2 Civatalı/bolt)

Örnek : R1A5045B 4 1A1H1DA

Example

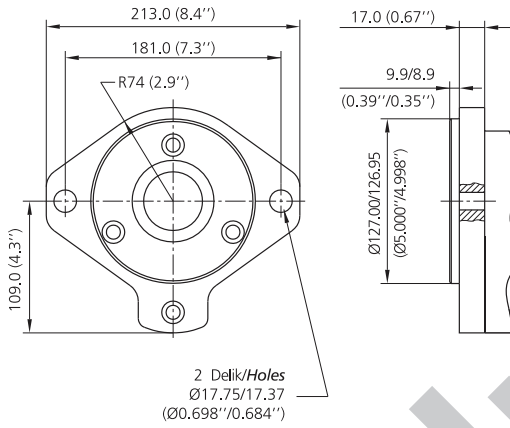
Kod  
Code

SAE 127-4 (C - 4 Civatalı/bolt)

Örnek : R1A5045B 5 1A1H1DA

Example

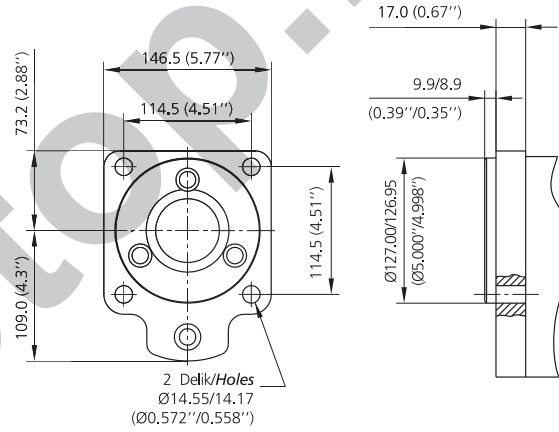

Hydroto

POMPA SAYISI VE GİRİŞ DELİĞİ KONUMLARI / NUMBER OF PUMP SECTIONS AND INLET PORT POSITIONS

Kod A  
Code

Şekil / Fig 1

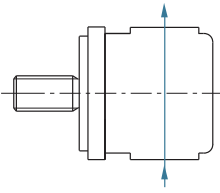

Kod C  
Code

Şekil / Fig 2

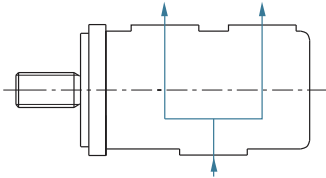

Kod B  
Code

Şekil / Fig 3

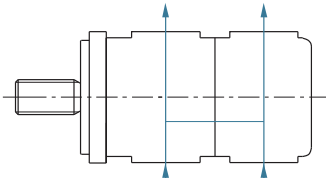

Kod A  
Code

Şekil / Fig 4

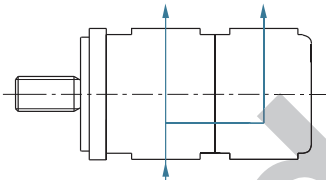

TEKLİ POMPA / SINGLE PUMP

Örnek / Example

**R1A5063Q51A1H1DC**

1 Pompa sayısı / Number of pump sections

A Giriş deliği konumu - şekil-1'e bakın / Inlet port position - see fig 1

1 Giriş deliği tipi - tablo 1'e bakın / Inlet port type - see table 1

H Giriş deliği ölçüleri - tablo 1'e bakın / Inlet port size - see table 1

1 Çıkış deliği tipi - tablo 2'ye bakın / Outlet port type - see table 2

D Çıkış deliği ölçüleri - tablo 2'ye bakın / Outlet port size - see table 2

C Dönüş yönü - Tahrik mili tarafında bakışa göre / Rotation - viewed from shaft

İKİLİ VEYA DUAL POMPA / MULTI PUMP

Örnek / Example

**R1A5085R5053C32C1L1F0X1DC**

2 Pompa sayısı / Number of pump sections

C Giriş deliği konumu - şekil-2, 3 veya 4'e bakın / Inlet port position - see figs 2, 3 or 4

1 1. Giriş deliği tipi - tablo 1'e bakın / 1st Inlet port type - see table 1

L 1. Giriş deliği ölçüleri - tablo 1'e bakın / 1st Inlet port size - see table 1

1 1. Çıkış deliği tipi - tablo 2'ye bakın / 1st Outlet port type - see table 2

F 1. Çıkış deliği ölçüleri - tablo 2'ye bakın / 1st Outlet port size - see table 2

O 2. Giriş deliği tipi - tablo 1'e bakın / 2nd Inlet port type - see table 1

X 2. Giriş deliği ölçüleri - tablo 1'e bakın / 2nd Inlet port size - see table 1

1 2. Çıkış deliği tipi - tablo 2'ye bakın / 2nd Outlet port type - see table 2

D 2. Çıkış deliği ölçüleri - tablo 2'ye bakın / 2nd Outlet port size - see table 2

C Dönüş yönü - Tahrik mili tarafında bakışa göre / Rotation - viewed from shaft

ÇOKLU POMPALAR / MULTIPLE PUMPS

Hema Endüstri A.Ş.'ye başvurunuz. / Please consult Hema Endüstri A.S.

SAE FLANŞLI DELİK ÖLÇÜLERİ / SAE FLANGE PORT DETAILS

SAE kod 61

SAE code 61

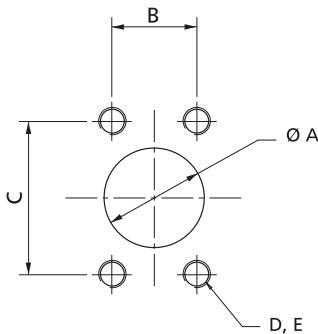

25.4	26.19	52.37	M10 x 1.5	22.4
(1.00)	(1.031)	(2.062)	3/8"-16 UNC	(0.88)
31.8	30.18	58.72	M10 x 1.5	28.4
(1.25)	(1.188)	(2.312)	7.16"-14 UNC	(1.12)
38.1	35.71	69.85	M12 x 1.75	26.9
(1.50)	(1.406)	(2.750)	1/2"-13 UNC	(1.06)
50.8	42.88	77.77	M12 x 1.75	26.9
(2.00)	(1.688)	(3.026)	1/2"-13 UNC	(1.06)
63.5	50.8	88.90	M12 x 1.75	30.2
(2.50)	(2.000)	(3.500)	1/2"-13 UNC	(1.19)

**TABLO 1 : GİRİŞ DELİĞİ OPSİYONLARI / TABLE 1 - INLET PORT OPTIONS**

Delik Tipi Port Type	TEKLİ POMPA GİRİŞ DELİĞİ OPSİYONLARI SINGLE PUMP INLET PORT OPTIONS												ORTAK GİRİŞ DELİĞİ OPSİYONLARI COMMON INLET PORT OPTIONS					İKİLİ GİRİŞ DELİĞİ OPSİYONLARI DUAL INLET PORT OPTIONS										
Delik Tipi Kodu Port Type Code	1				2				4				1					2					1			2		
Delik Tipi Port Type	SAE Flanş Metrik SAE Flange Metric				SAE Flanş UNC SAE Flange UNC				UNF O-ring				SAE Flanş Metrik SAE Flange Metric					SAE Flanş UNC SAE Flange UNC					SAE Flanş Metrik SAE Flange Metric			SAE Flanş UNC SAE Flange UNC		
Delik Ölçü Kodu Port Size Code	D	F	H	K	D	F	H	K	C	E	G	J	D	F	H	K	L	D	H	K	L	H	K	L	H	K	L	
Delik Ölçüsü Port Size	1	1.1/4	1.1/2	2	1	1.1/4	1.1/2	2	7/8	1.1/16	1.5/16	1.5/8	1	1.1/4	1.1/2	2	2.1/2	1	1.1/4	2	2.1/2	1.1/2	2	2.1/2	1.1/2	2	2.1/2	
R5045	<input type="checkbox"/>	<input type="checkbox"/>	<input checked="" type="checkbox"/>	<input type="checkbox"/>	<input type="checkbox"/>	<input type="checkbox"/>	<input checked="" type="checkbox"/>	<input type="checkbox"/>	<input checked="" type="checkbox"/>	<input type="checkbox"/>	<input type="checkbox"/>	<input type="checkbox"/>	<input type="checkbox"/>	<input type="checkbox"/>	<input type="checkbox"/>	<input checked="" type="checkbox"/>	<input type="checkbox"/>	<input type="checkbox"/>	<input type="checkbox"/>	<input checked="" type="checkbox"/>	<input type="checkbox"/>	<input type="checkbox"/>	<input checked="" type="checkbox"/>	<input type="checkbox"/>	<input type="checkbox"/>	<input checked="" type="checkbox"/>		
R5053	<input type="checkbox"/>	<input type="checkbox"/>	<input checked="" type="checkbox"/>	<input type="checkbox"/>	<input type="checkbox"/>	<input type="checkbox"/>	<input checked="" type="checkbox"/>	<input type="checkbox"/>	<input checked="" type="checkbox"/>	<input type="checkbox"/>	<input type="checkbox"/>	<input type="checkbox"/>	<input type="checkbox"/>	<input type="checkbox"/>	<input type="checkbox"/>	<input checked="" type="checkbox"/>	<input type="checkbox"/>	<input type="checkbox"/>	<input type="checkbox"/>	<input checked="" type="checkbox"/>	<input type="checkbox"/>	<input type="checkbox"/>	<input checked="" type="checkbox"/>	<input type="checkbox"/>	<input type="checkbox"/>	<input checked="" type="checkbox"/>		
R5063	<input type="checkbox"/>	<input type="checkbox"/>	<input checked="" type="checkbox"/>	<input type="checkbox"/>	<input type="checkbox"/>	<input type="checkbox"/>	<input checked="" type="checkbox"/>	<input type="checkbox"/>	<input checked="" type="checkbox"/>	<input type="checkbox"/>	<input type="checkbox"/>	<input type="checkbox"/>	<input type="checkbox"/>	<input type="checkbox"/>	<input type="checkbox"/>	<input checked="" type="checkbox"/>	<input type="checkbox"/>	<input type="checkbox"/>	<input type="checkbox"/>	<input checked="" type="checkbox"/>	<input type="checkbox"/>	<input type="checkbox"/>	<input checked="" type="checkbox"/>	<input type="checkbox"/>	<input type="checkbox"/>	<input checked="" type="checkbox"/>		
R5073	<input type="checkbox"/>	<input type="checkbox"/>	<input type="checkbox"/>	<input checked="" type="checkbox"/>	<input type="checkbox"/>	<input type="checkbox"/>	<input checked="" type="checkbox"/>	<input type="checkbox"/>	<input checked="" type="checkbox"/>	<input type="checkbox"/>	<input type="checkbox"/>	<input type="checkbox"/>	<input type="checkbox"/>	<input type="checkbox"/>	<input type="checkbox"/>	<input checked="" type="checkbox"/>	<input type="checkbox"/>	<input type="checkbox"/>	<input type="checkbox"/>	<input checked="" type="checkbox"/>	<input type="checkbox"/>	<input type="checkbox"/>	<input checked="" type="checkbox"/>	<input type="checkbox"/>	<input type="checkbox"/>	<input checked="" type="checkbox"/>		
R5085	<input type="checkbox"/>	<input type="checkbox"/>	<input type="checkbox"/>	<input checked="" type="checkbox"/>	<input type="checkbox"/>	<input type="checkbox"/>	<input checked="" type="checkbox"/>	<input type="checkbox"/>	<input checked="" type="checkbox"/>	<input type="checkbox"/>	<input type="checkbox"/>	<input type="checkbox"/>	<input type="checkbox"/>	<input type="checkbox"/>	<input type="checkbox"/>	<input checked="" type="checkbox"/>	<input type="checkbox"/>	<input type="checkbox"/>	<input type="checkbox"/>	<input checked="" type="checkbox"/>	<input type="checkbox"/>	<input type="checkbox"/>	<input checked="" type="checkbox"/>	<input type="checkbox"/>	<input type="checkbox"/>	<input checked="" type="checkbox"/>		
R5100	<input type="checkbox"/>	<input type="checkbox"/>	<input type="checkbox"/>	<input checked="" type="checkbox"/>	<input type="checkbox"/>	<input type="checkbox"/>	<input checked="" type="checkbox"/>	<input type="checkbox"/>	<input checked="" type="checkbox"/>	<input type="checkbox"/>	<input type="checkbox"/>	<input type="checkbox"/>	<input type="checkbox"/>	<input type="checkbox"/>	<input type="checkbox"/>	<input checked="" type="checkbox"/>	<input type="checkbox"/>	<input type="checkbox"/>	<input type="checkbox"/>	<input checked="" type="checkbox"/>	<input type="checkbox"/>	<input type="checkbox"/>	<input checked="" type="checkbox"/>	<input type="checkbox"/>	<input type="checkbox"/>	<input checked="" type="checkbox"/>		
R5120	<input type="checkbox"/>	<input type="checkbox"/>	<input type="checkbox"/>	<input checked="" type="checkbox"/>	<input type="checkbox"/>	<input type="checkbox"/>	<input checked="" type="checkbox"/>	<input type="checkbox"/>	<input checked="" type="checkbox"/>	<input type="checkbox"/>	<input type="checkbox"/>	<input type="checkbox"/>	<input type="checkbox"/>	<input type="checkbox"/>	<input type="checkbox"/>	<input checked="" type="checkbox"/>	<input type="checkbox"/>	<input type="checkbox"/>	<input type="checkbox"/>	<input checked="" type="checkbox"/>	<input type="checkbox"/>	<input type="checkbox"/>	<input checked="" type="checkbox"/>	<input type="checkbox"/>	<input type="checkbox"/>	<input checked="" type="checkbox"/>		
S5045	<input type="checkbox"/>	<input type="checkbox"/>	<input checked="" type="checkbox"/>	<input type="checkbox"/>	<input type="checkbox"/>	<input type="checkbox"/>	<input checked="" type="checkbox"/>	<input type="checkbox"/>	<input checked="" type="checkbox"/>	<input type="checkbox"/>	<input type="checkbox"/>	<input type="checkbox"/>	<input type="checkbox"/>	<input type="checkbox"/>	<input type="checkbox"/>	<input checked="" type="checkbox"/>	<input type="checkbox"/>	<input type="checkbox"/>	<input type="checkbox"/>	<input checked="" type="checkbox"/>	<input type="checkbox"/>	<input type="checkbox"/>	<input checked="" type="checkbox"/>	<input type="checkbox"/>	<input type="checkbox"/>	<input checked="" type="checkbox"/>		
S5051	<input type="checkbox"/>	<input type="checkbox"/>	<input checked="" type="checkbox"/>	<input type="checkbox"/>	<input type="checkbox"/>	<input type="checkbox"/>	<input checked="" type="checkbox"/>	<input type="checkbox"/>	<input checked="" type="checkbox"/>	<input type="checkbox"/>	<input type="checkbox"/>	<input type="checkbox"/>	<input type="checkbox"/>	<input type="checkbox"/>	<input type="checkbox"/>	<input checked="" type="checkbox"/>	<input type="checkbox"/>	<input type="checkbox"/>	<input type="checkbox"/>	<input checked="" type="checkbox"/>	<input type="checkbox"/>	<input type="checkbox"/>	<input checked="" type="checkbox"/>	<input type="checkbox"/>	<input type="checkbox"/>	<input checked="" type="checkbox"/>		
S5060	<input type="checkbox"/>	<input type="checkbox"/>	<input checked="" type="checkbox"/>	<input type="checkbox"/>	<input type="checkbox"/>	<input type="checkbox"/>	<input checked="" type="checkbox"/>	<input type="checkbox"/>	<input checked="" type="checkbox"/>	<input type="checkbox"/>	<input type="checkbox"/>	<input type="checkbox"/>	<input type="checkbox"/>	<input type="checkbox"/>	<input type="checkbox"/>	<input checked="" type="checkbox"/>	<input type="checkbox"/>	<input type="checkbox"/>	<input type="checkbox"/>	<input checked="" type="checkbox"/>	<input type="checkbox"/>	<input type="checkbox"/>	<input checked="" type="checkbox"/>	<input type="checkbox"/>	<input type="checkbox"/>	<input checked="" type="checkbox"/>		
S5070	<input type="checkbox"/>	<input type="checkbox"/>	<input type="checkbox"/>	<input checked="" type="checkbox"/>	<input type="checkbox"/>	<input type="checkbox"/>	<input checked="" type="checkbox"/>	<input type="checkbox"/>	<input checked="" type="checkbox"/>	<input type="checkbox"/>	<input type="checkbox"/>	<input type="checkbox"/>	<input type="checkbox"/>	<input type="checkbox"/>	<input type="checkbox"/>	<input checked="" type="checkbox"/>	<input type="checkbox"/>	<input type="checkbox"/>	<input type="checkbox"/>	<input checked="" type="checkbox"/>	<input type="checkbox"/>	<input type="checkbox"/>	<input checked="" type="checkbox"/>	<input type="checkbox"/>	<input type="checkbox"/>	<input checked="" type="checkbox"/>		
S5085	<input type="checkbox"/>	<input type="checkbox"/>	<input type="checkbox"/>	<input checked="" type="checkbox"/>	<input type="checkbox"/>	<input type="checkbox"/>	<input checked="" type="checkbox"/>	<input type="checkbox"/>	<input checked="" type="checkbox"/>	<input type="checkbox"/>	<input type="checkbox"/>	<input type="checkbox"/>	<input type="checkbox"/>	<input type="checkbox"/>	<input type="checkbox"/>	<input checked="" type="checkbox"/>	<input type="checkbox"/>	<input type="checkbox"/>	<input type="checkbox"/>	<input checked="" type="checkbox"/>	<input type="checkbox"/>	<input type="checkbox"/>	<input checked="" type="checkbox"/>	<input type="checkbox"/>	<input type="checkbox"/>	<input checked="" type="checkbox"/>		

Tercih edilen delik tipi Preferred port size  Tercih edilmeyen delik tipi Non-preferred port size

Not / Note :

Tek girişli çoklu pompaların model numarasını oluştururken, "2. giriş deliği tipi" için "0" ve "2. giriş deliği ölçüsü" için "X" kodunu kullanınız.

When coding, for single inlet multiple pumps, use '0' in 2nd inlet port type' and 'X' in '2nd inlet port size' in he model number.

**TABLO 2 : ÇIKIŞ DELİĞİ OPSİYONLARI / TABLE 2 - OUTLET PORT OPTIONS**

Delik Tipi Kodu Port Type Code	3				1				2				4			
Delik Tipi Port Type	BSPP				SAE Flanş Metrik SAE Flange Metric				SAE Flanş UNC SAE Flange UNC				UNF O-ring			
Delik Ölçü Kodu Port Size Code	A	B	D	F	A	B	D	F	A	B	D	F	C	E	G	J
Delik Ölçüsü Port Size	1/2	3/4	1	1.1/4	1/2	3/4	1	1.1/4	1/2	3/4	1	1.1/4	7/8	1.1/16	1.5/16	1.5/8
R5045	<input type="checkbox"/>	<input type="checkbox"/>	<input checked="" type="checkbox"/>	<input type="checkbox"/>	<input type="checkbox"/>	<input type="checkbox"/>	<input checked="" type="checkbox"/>	<input type="checkbox"/>	<input type="checkbox"/>	<input type="checkbox"/>	<input checked="" type="checkbox"/>	<input type="checkbox"/>	<input type="checkbox"/>	<input type="checkbox"/>	<input checked="" type="checkbox"/>	<input type="checkbox"/>
R5053	<input type="checkbox"/>	<input checked="" type="checkbox"/>	<input checked="" type="checkbox"/>	<input type="checkbox"/>	<input type="checkbox"/>	<input type="checkbox"/>	<input checked="" type="checkbox"/>	<input type="checkbox"/>	<input type="checkbox"/>	<input type="checkbox"/>	<input checked="" type="checkbox"/>	<input type="checkbox"/>	<input type="checkbox"/>	<input type="checkbox"/>	<input checked="" type="checkbox"/>	<input type="checkbox"/>
R5063	<input type="checkbox"/>	<input type="checkbox"/>	<input checked="" type="checkbox"/>	<input type="checkbox"/>	<input type="checkbox"/>	<input type="checkbox"/>	<input checked="" type="checkbox"/>	<input type="checkbox"/>	<input type="checkbox"/>	<input type="checkbox"/>	<input checked="" type="checkbox"/>	<input type="checkbox"/>	<input type="checkbox"/>	<input type="checkbox"/>	<input checked="" type="checkbox"/>	<input type="checkbox"/>
R5073	<input type="checkbox"/>	<input type="checkbox"/>	<input checked="" type="checkbox"/>	<input type="checkbox"/>	<input type="checkbox"/>	<input type="checkbox"/>	<input checked="" type="checkbox"/>	<input type="checkbox"/>	<input type="checkbox"/>	<input type="checkbox"/>	<input checked="" type="checkbox"/>	<input type="checkbox"/>	<input type="checkbox"/>	<input type="checkbox"/>	<input checked="" type="checkbox"/>	<input type="checkbox"/>
R5085	<input type="checkbox"/>	<input type="checkbox"/>	<input checked="" type="checkbox"/>	<input type="checkbox"/>	<input type="checkbox"/>	<input type="checkbox"/>	<input checked="" type="checkbox"/>	<input type="checkbox"/>	<input type="checkbox"/>	<input type="checkbox"/>	<input checked="" type="checkbox"/>	<input type="checkbox"/>	<input type="checkbox"/>	<input type="checkbox"/>	<input checked="" type="checkbox"/>	<input type="checkbox"/>
R5100	<input type="checkbox"/>	<input type="checkbox"/>	<input checked="" type="checkbox"/>	<input type="checkbox"/>	<input type="checkbox"/>	<input type="checkbox"/>	<input checked="" type="checkbox"/>	<input type="checkbox"/>	<input type="checkbox"/>	<input type="checkbox"/>	<input checked="" type="checkbox"/>	<input type="checkbox"/>	<input type="checkbox"/>	<input type="checkbox"/>	<input checked="" type="checkbox"/>	<input type="checkbox"/>
R5120	<input type="checkbox"/>	<input type="checkbox"/>	<input checked="" type="checkbox"/>	<input type="checkbox"/>	<input type="checkbox"/>	<input type="checkbox"/>	<input checked="" type="checkbox"/>	<input type="checkbox"/>	<input type="checkbox"/>	<input type="checkbox"/>	<input checked="" type="checkbox"/>	<input type="checkbox"/>	<input type="checkbox"/>	<input type="checkbox"/>	<input checked="" type="checkbox"/>	<input type="checkbox"/>
S5045	<input type="checkbox"/>	<input type="checkbox"/>	<input checked="" type="checkbox"/>	<input type="checkbox"/>	<input type="checkbox"/>	<input type="checkbox"/>	<input checked="" type="checkbox"/>	<input type="checkbox"/>	<input type="checkbox"/>	<input type="checkbox"/>	<input checked="" type="checkbox"/>	<input type="checkbox"/>	<input type="checkbox"/>	<input type="checkbox"/>	<input checked="" type="checkbox"/>	<input type="checkbox"/>
S5051	<input type="checkbox"/>	<input type="checkbox"/>	<input checked="" type="checkbox"/>	<input type="checkbox"/>	<input type="checkbox"/>	<input type="checkbox"/>	<input checked="" type="checkbox"/>	<input type="checkbox"/>	<input type="checkbox"/>	<input type="checkbox"/>	<input checked="" type="checkbox"/>	<input type="checkbox"/>	<input type="checkbox"/>	<input type="checkbox"/>	<input checked="" type="checkbox"/>	<input type="checkbox"/>
S5060	<input type="checkbox"/>	<input type="checkbox"/>	<input checked="" type="checkbox"/>	<input type="checkbox"/>	<input type="checkbox"/>	<input type="checkbox"/>	<input checked="" type="checkbox"/>	<input type="checkbox"/>	<input type="checkbox"/>	<input type="checkbox"/>	<input checked="" type="checkbox"/>	<input type="checkbox"/>	<input type="checkbox"/>	<input type="checkbox"/>	<input checked="" type="checkbox"/>	<input type="checkbox"/>
S5070	<input type="checkbox"/>	<input type="checkbox"/>	<input checked="" type="checkbox"/>	<input type="checkbox"/>	<input type="checkbox"/>	<input type="checkbox"/>	<input checked="" type="checkbox"/>	<input type="checkbox"/>	<input type="checkbox"/>	<input type="checkbox"/>	<input checked="" type="checkbox"/>	<input type="checkbox"/>	<input type="checkbox"/>	<input type="checkbox"/>	<input checked="" type="checkbox"/>	<input type="checkbox"/>
S5085	<input type="checkbox"/>	<input type="checkbox"/>	<input checked="" type="checkbox"/>	<input type="checkbox"/>	<input type="checkbox"/>	<input type="checkbox"/>	<input checked="" type="checkbox"/>	<input type="checkbox"/>	<input type="checkbox"/>	<input type="checkbox"/>	<input checked="" type="checkbox"/>	<input type="checkbox"/>	<input type="checkbox"/>	<input type="checkbox"/>	<input checked="" type="checkbox"/>	<input type="checkbox"/>

Tercih edilen delik tipi Preferred port size  Tercih edilmeyen delik tipi Non-preferred port size

## Not / Note

Aşağıdaki çizimler saat yönü dönüşlü pompalarıdır. Saat yönünün tersi dönüşlü pompalarda giriş ve çıkış delikleri yer değişir. (Dönüş yönü tayini, tahrik mili tarafında bakışa göredir.)

Drawings show clockwise rotation pumps. For anti-clockwise rotation pumps reverse the inlet and outlet port positions. (Rotation convention – view from pump shaft end).

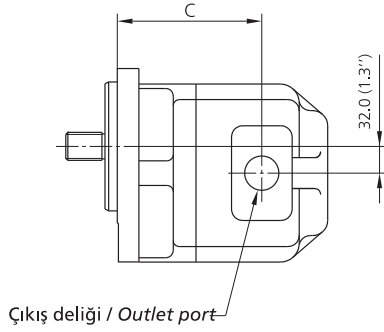
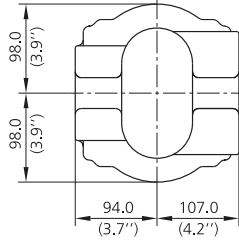
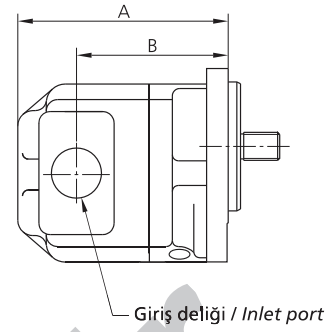
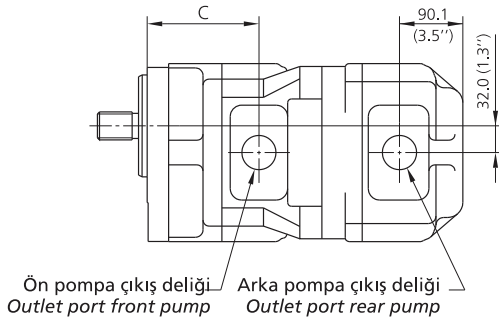
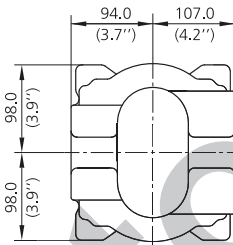
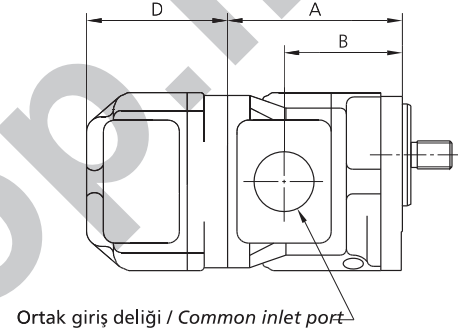
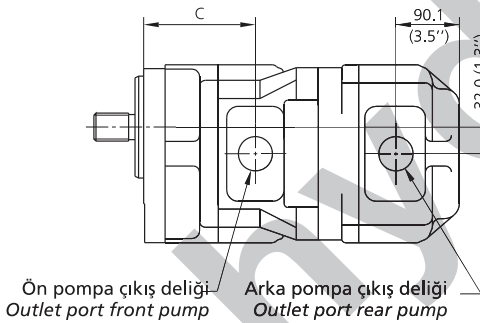
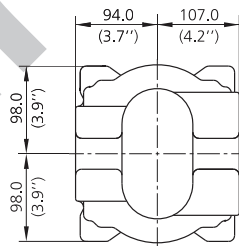
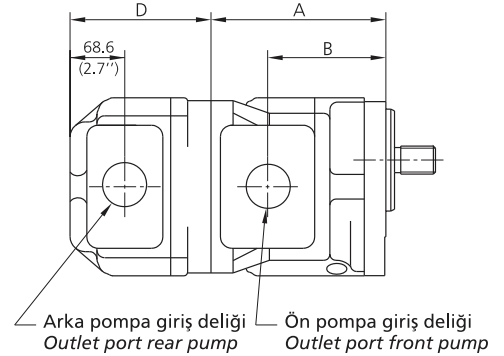
**TEKLİ POMPALAR** - standart delikler  
**SINGLE PUMPS** - standard ports

**Kod A**  
**Code**

**Örnek : R1A6100C41 A 1L1HC**  
**Example :**

**İKİLİ POMPALAR** - 1 giriş / 2 çıkış  
**DOUBLE PUMPS** - 1 inlet / 2 outlets

**Kod A**  
**Code**

**Örnek : R1A6100R6100T42 A 1M1H0X1HC**  
**Example :**

**İKİLİ POMPALAR** - 2 giriş / 2 çıkış  
**DOUBLE PUMPS** - 2 inlets / 2 outlets

**Kod B**  
**Code**

**Örnek : R1A6100R6100T42 B 1L1H1L1HC**  
**Example :**

**ÜÇLÜ VE DÖRTLÜ POMPALAR** - 39. ve 40. sayfalara bakınız.  
**TRIPLE AND QUADRUPLE PUMPS** - See pages 39 and 40.



POMPA PUMP	A	B	C	D	AĞIRLIK WEIGHT		
	mm (in)	mm (in)	mm (in)	mm (in)	Tekli* Single	Ön* Front	Arka* Rear
R6100	220.0 (8.66)	152.0 (5.98)	130.0 (5.12)	182.0 (7.16)	35.0 (77.0)	40.0 (88.0)	30.0 (66.0)
R6117	226.0 (8.90)	158.0 (6.22)	136.0 (5.35)	188.0 (7.40)	36.5 (80.0)	41.5 (91.0)	31.5 (69.0)
R6137	233.0 (9.17)	165.0 (6.50)	143.0 (5.63)	195.0 (7.68)	39.0 (86.0)	44.0 (97.0)	34.0 (75.0)
R6160	241.0 (9.49)	173.0 (6.81)	151.0 (5.94)	203.0 (7.99)	42.0 (92.0)	47.0 (43.0)	37.0 (81.0)
R6187	251.0 (9.88)	182.0 (7.16)	161.0 (6.34)	213.0 (8.38)	45.3 (100.0)	50.3 (111.0)	40.3 (89.0)
R6220	263.0 (10.35)	194.0 (7.64)	173.0 (6.81)	225.0 (8.86)	49.0 (108.0)	54.0 (119.0)	44.0 (97.0)
S6083	226.0 (8.90)	158.0 (6.22)	136.0 (5.35)	188.0 (7.40)	40.5 (39.0)	45.5 (100.0)	35.5 (77.0)
S6097	234.0 (9.21)	165.0 (6.50)	143.0 (5.63)	196.0 (7.72)	42.0 (92.0)	47.0 (103.0)	37.0 (87.0)
S6113	242.9 (9.56)	173.0 (6.81)	151.0 (5.94)	204.0 (8.03)	43.0 (96.0)	48.5 (107.0)	38.5 (85.0)
S6132	251.0 (9.88)	183.0 (7.20)	161.0 (6.34)	213.0 (8.39)	45.5 (100.0)	50.5 (111.0)	40.5 (89.0)
S6115	263.0 (10.35)	194.0 (7.64)	173.0 (6.81)	225.0 (8.86)	47.5 (105.0)	52.5 (116.0)	42.5 (94.0)

\*Not / Note :

Ağırlıklar yaklaşık değerlerdir.

İkili pompa ağırlığı = (ön pompa + arka pompa) ağırlığı

Weights are approximate.

Double pump weight = (front + rear) weights

Hydrotop.ir

## QR6 SERİSİ / QR6 SERIES

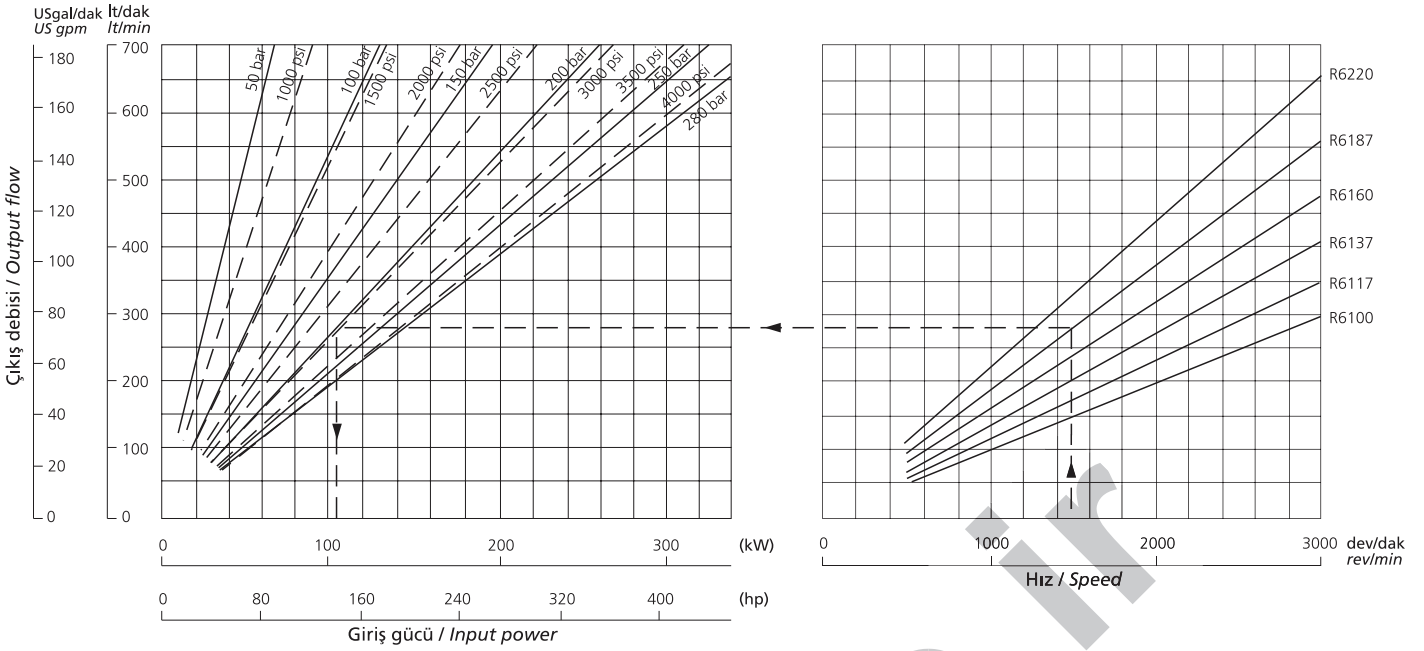

ÇIKIŞ DEBİLERİ teorik değerlerdir. Genelde volümetrik verim %95'tan fazladır.

GİRİŞ GÜÇLERİ gerçek değerlerdir. Ortalama verim hesaba katılmıştır. Çıkış basıncı 50 bar'dan daha az olursa Hema Endüstri A.Ş.'ye danışılmalıdır.

Örnek: R6187 pompası 1500 dev/dak'da, 281 lt/dak (74 USgal/dak) debi sağlar ve 200 bar (2900 psi) çıkış basıncında çalıştırmak için 107 kW (144 hp) güç gerekir.

OUTPUT FLOWS are theoretical. Generally volumetric efficiencies are in excess of 95%

INPUT POWERS are actual, taking into account average efficiencies. Please consult Hema Endustri A.S. when output pressure is less than 50 bar.

Example : R6187 at 1500 rev/min gives output flow of 281 l/min (74 US gall/min) and requires 107 kW (144 hp) to drive it at 200 bar (2900 psi).

## QS6 SERİSİ / QS6 SERIES

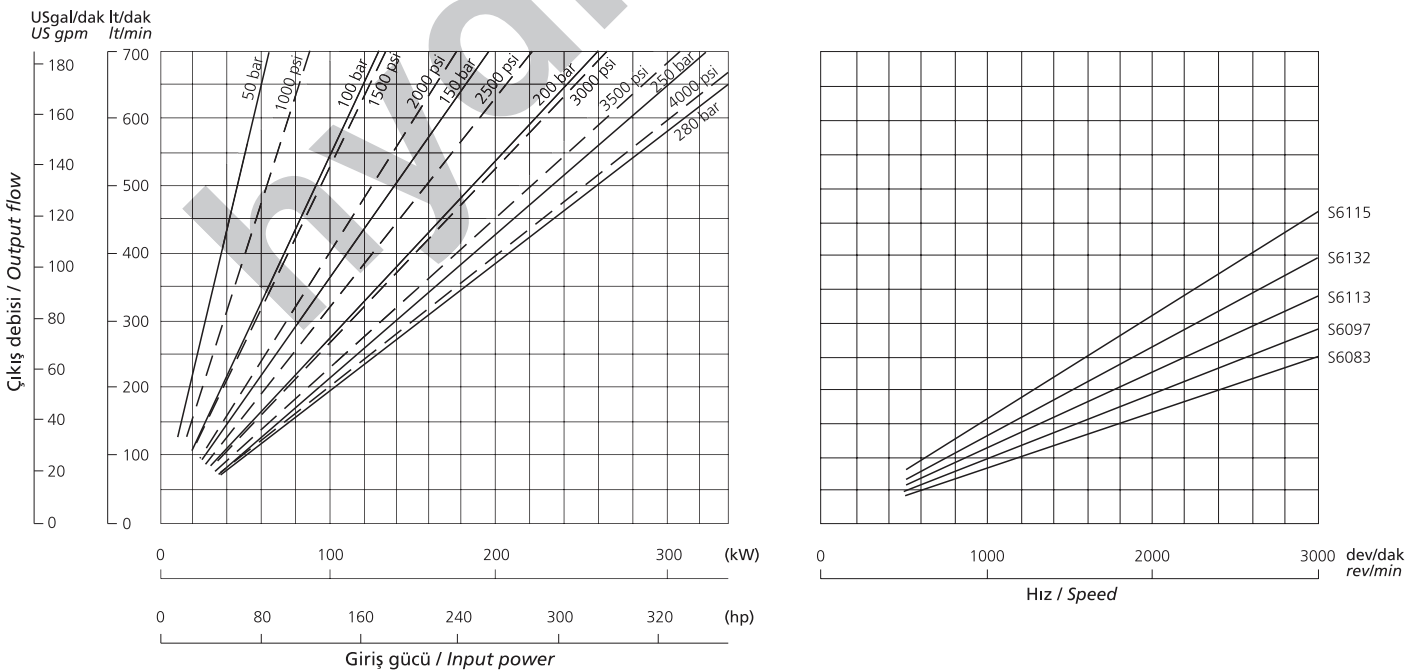

Eğriler 50°C (120°F)'de 23 cSt (110 SSU) yağ kullanılarak ortalama pompalar için çizilmiştir.

Curves drawn for average pumps at 50°C (120°F) - fluid viscosity 23 cSt (110 SSU).

## POMPA VERİMİ / PUMP EFFICIENCIES

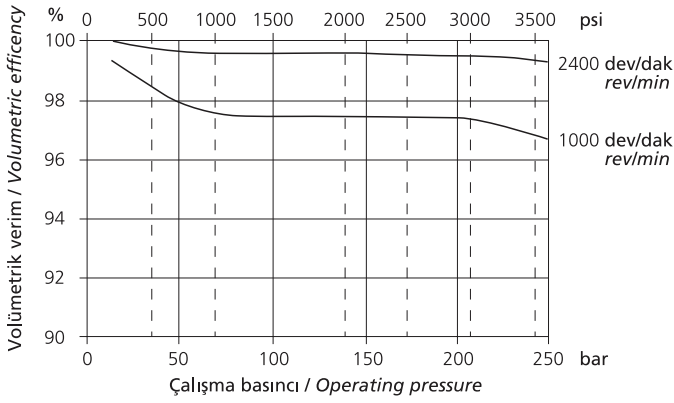

Bütün Q serisi pompalar çok yüksek verimlerde çalışır. Yandaki grafik 1000 ve 2400 dev/dak'da QS6 pompasının volümetrik verim eğrilerini gösterir.

All Q series pumps share very high efficiencies. The graph shows typical QS6 volumetric efficiency curves at 1000 and 2400 rev/min.

## GÜRÜLTÜ SEVİYESİ / NOISE LEVELS

6. sayfada belirtildiği gibi Q serisi pompaların geliştirilmesindeki en önemli faktör gürültü seviyesinin azaltılmasıdır. QR6 ve QS6 serisi pompaların, ISO 9614-4'e göre elde edilen, pompadan 1 metre uzaklıktaki ses basıncı seviyelerinin grafikleri aşağıda gösterilmiştir.

As described on page 6, the reduction of noise levels was a major factor in the development of the Q Series Pumps. The following graphs show QR6 and QS6 sound pressure levels at one meter from the pump obtained in accordance with ISO 9614-4.

## 1000 dev/dak'daki ses basıncı / Sound Pressure at 1000 rpm

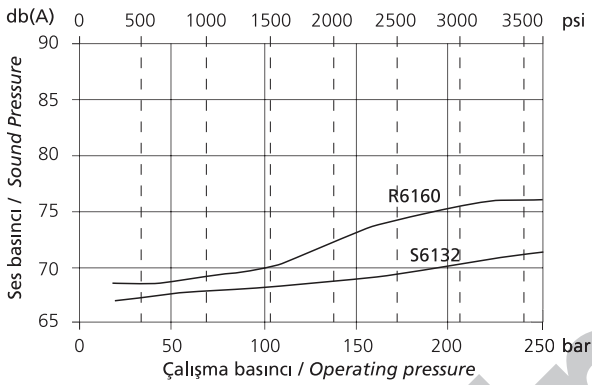

## 1500 dev/dak'daki ses basıncı / Sound Pressure at 1500 rpm

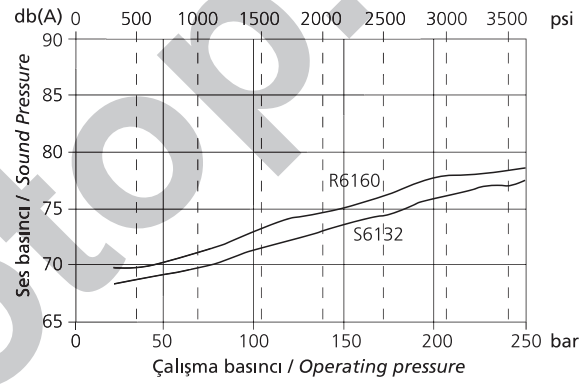

## 1800 dev/dak'daki ses basıncı / Sound Pressure at 1800 rpm

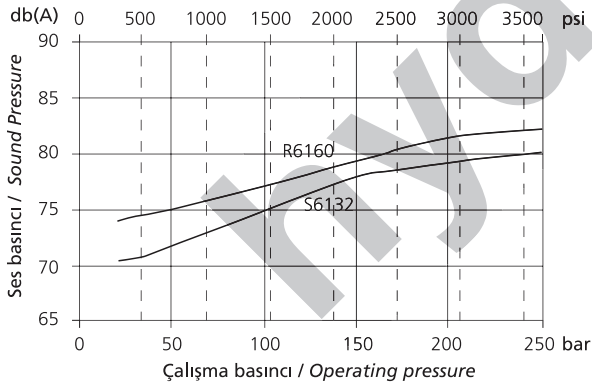

## 2400 dev/dak'daki ses basıncı / Sound Pressure at 2400 rpm

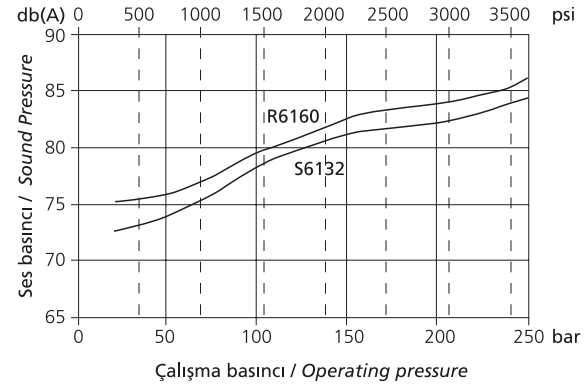

## EYLEMSİZLİK MOMENTİ / MOMENTS OF INERTIA

## QR6 SERİSİ / QR6 SERIES

POMPA TİPİ / PUMP SIZE		R6100	R6117	R6137	R6160	R6187	R6220
Eylemsizlik momenti Moment of Inertia	kg cm <sup>2</sup> (lb in <sup>2</sup> )	16.18 (5.50)	17.76 (6.04)	19.61 (6.67)	21.74 (7.40)	24.24 (8.24)	27.29 (9.28)

## QS6 SERİSİ / QS6 SERIES

POMPA TİPİ / PUMP SIZE		S6083	S6097	S6113	S6132	S6155
Eylemsizlik momenti Moment of Inertia	kg cm <sup>2</sup> (lb in <sup>2</sup> )	21.71 (7.38)	23.50 (7.99)	25.55 (8.69)	27.98 (9.51)	30.92 (10.51)

ŞAFT KEÇELERİ / SHAFT SEALS

Kod **A** Dıştan tahrikler için şaft keçesi ve toz keçesi  
Code Shaft seal and wiper for external drives

Örnek : R1 **A** 6100C51A1L1HA  
Example :

Kod **C** Tork dönüştürücüsü ve dişli kutusu ile tahrik için kaçak kontrol delikli toz keçesi-keçe ve şaft keçesi.  
Code Shaft seal, wiper and seal with tell-tale hole for torque converter and gearbox drives. The tell-tale hole indicates leakage before mixing of fluids can occur.

Örnek : R1 **C** 6100C41A1L1HA  
Example :

TAHRİK MİLLERİ / DRIVE SHAFTS

Kod **C** SAE 32-4 (C) 1.1/4" spline  
Code Örnek : R1A6100 **C** 41A1L1HA  
Example

Evolvent spline / Involute spline  
14 Diş / 14 Teeth  
12/24 DP  
Diş dibi düz / Flat root  
Yanaktan alıştırımlı / Side fit  
30° kavrama açısı / 30° pressure angle  
Diş üstü çapı / Major Dia: 31.22/31.12 (1.229"/1.225")

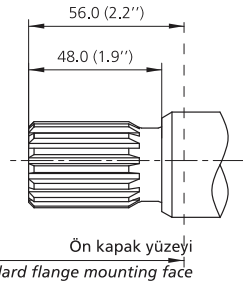

$p \times D = 45565$  (bar x cm<sup>3</sup>/dev)\*  
(bar x cm<sup>3</sup>/rev)  
 $p \times D = 40325$  (psi x in<sup>3</sup>/dev)\*  
(psi x in<sup>3</sup>/rev)

Kod **G** SAE 32-1 (C) 1.1/4" paralel / parallel  
Code Örnek : R1A6100 **G** 41A1L1HA  
Example :

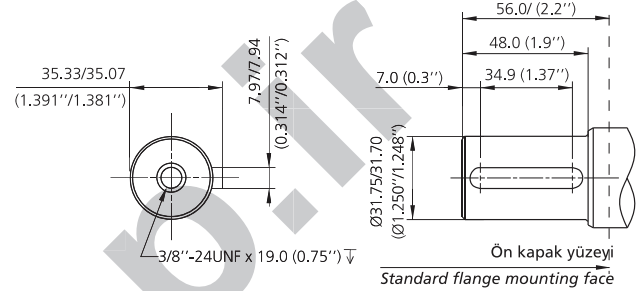

$p \times D = 45565$  (bar x cm<sup>3</sup>/dev)\*  
(bar x cm<sup>3</sup>/rev)  
 $p \times D = 40325$  (psi x in<sup>3</sup>/dev)\*  
(psi x in<sup>3</sup>/rev)

Kod **T** SAE 38-4 (CC) 1.1/2" spline  
Code Örnek : R1A6100 **T** 41A1L1HA  
Example

Evolvent spline / Involute spline  
17 Diş / 17 Teeth  
12/24 DP  
Diş dibi düz / Flat root  
Yanaktan alıştırımlı / Side fit  
30° kavrama açısı / 30° pressure angle  
Diş üstü çapı / Major Dia: 37.57/37.44 (1.479"/1.474")

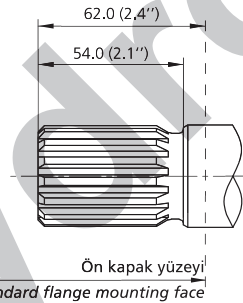

$p \times D = 86950$  (bar x cm<sup>3</sup>/dev)\*  
(bar x cm<sup>3</sup>/rev)  
 $p \times D = 76950$  (psi x in<sup>3</sup>/dev)\*  
(psi x in<sup>3</sup>/rev)

Kod **N** SAE 38-1 (CC) 1.1/2" paralel / parallel  
Code Örnek : R1A6100 **N** 41A1L1HA  
Example :

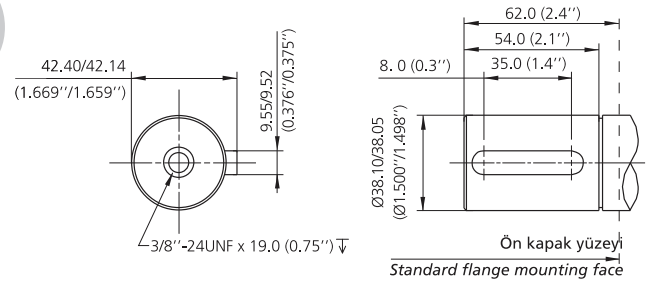

$p \times D = 86950$  (bar x cm<sup>3</sup>/dev)\*  
(bar x cm<sup>3</sup>/rev)  
 $p \times D = 76950$  (psi x in<sup>3</sup>/dev)\*  
(psi x in<sup>3</sup>/rev)

\* p=basınç, D=iletim hacmi. Belirtilen değerler aşılmamalıdır.  
Not: Çoklu pompalarda, p x D değerlerinin toplamı belirtilen değeri aşmamalıdır. Sayfa 39'a bakınız.

\* p = pressure, D = displacement. The stated values must not be exceeded.  
Note: For multiple pumps the sum of the p x D values must not exceed the stated value. See Page 39.

Kod 4  
Code

SAE 127-2 (C - 2 civatalı / bolt)

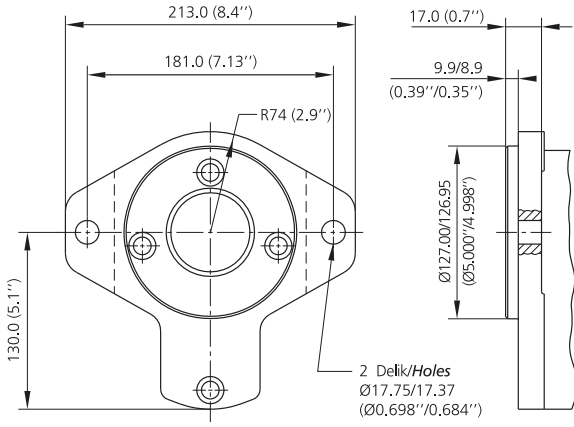
Örnek : R1A6100C 4 1A1L1HA  
Example :Kod 5  
Code

SAE 127-4 (C - 4 civatalı / bolt)

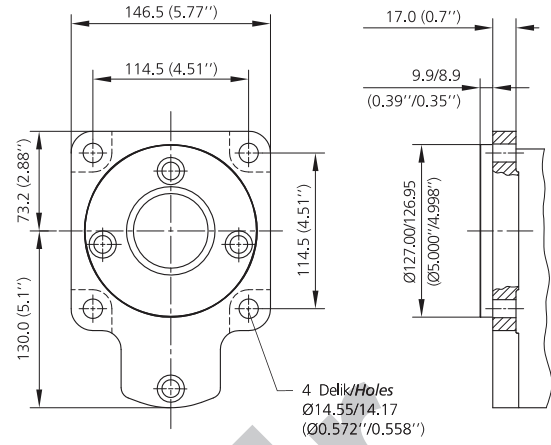
Örnek : R1A6100C 5 1A1L1HA  
Example :

hydrotop.in

POMPA SAYISI VE GİRİŞ DELİĞİ KONUMLARI / NUMBER OF PUMP SECTIONS AND INLET PORT POSITIONS

Kod A  
Code

Şekil / Fig 1

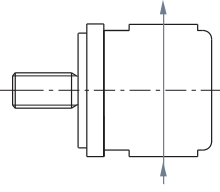

Kod B  
Code

Şekil / Fig 2

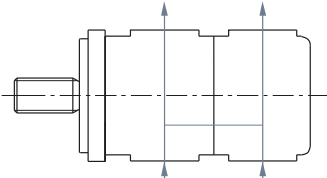

Kod A  
Code

Şekil / Fig 3

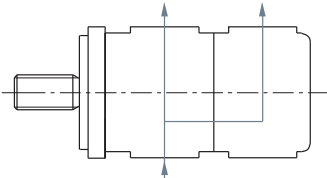

TEKLİ POMPA / SINGLE PUMP

Örnek / Example

**R1A6160C51A1L1HC**

1 Pompa sayısı / Number of pump sections

A Giriş deliği konumu - şekil-1'e bakın / Inlet port position - see fig 1

1 Giriş deliği tipi - tablo 1'e bakın / Inlet port type - see table 1

L Giriş deliği ölçüleri - tablo 1'e bakın / Inlet port size - see table 1

1 Çıkış deliği tipi - tablo 2'ye bakın / Outlet port type - see table 2

H Çıkış deliği ölçüleri - tablo 2'ye bakın / Outlet port size - see table 2

C Dönüş yönü - Tahrik mili tarafında bakışa göre / Rotation - viewed from shaft

İKİLİ VEYA DUAL POMPA / MULTI PUMP

Örnek / Example

**R1A6160R6100T52A1M1H0X1HC**

2 Pompa sayısı / Number of pump sections

A Giriş deliği konumu - şekil-2 veya 3'e bakın / Inlet port position - see figs 2 or 3

1 1. Giriş deliği tipi - tablo 1'e bakın / 1st Inlet port type - see table 1

M 1. Giriş deliği ölçüleri - tablo 1'e bakın / 1st Inlet port size - see table 1

1 1. Çıkış deliği tipi - tablo 2'ye bakın / 1st Outlet port type - see table 2

H 1. Çıkış deliği ölçüleri - tablo 2'ye bakın / 1st Outlet port size - see table 2

O 2. Giriş deliği tipi - tablo 1'e bakın / 2nd Inlet port type - see table 1

X 2. Giriş deliği ölçüleri - tablo 1'e bakın / 2nd Inlet port size - see table 1

1 2. Çıkış deliği tipi - tablo 2'ye bakın / 2nd Outlet port type - see table 2

H 2. Çıkış deliği ölçüleri - tablo 2'ye bakın / 2nd Outlet port size - see table 2

C Dönüş yönü - Tahrik mili tarafında bakışa göre / Rotation - viewed from shaft

ÇOKLU POMPALAR / MULTIPLE PUMPS

Hema Endüstri A.Ş.'ye başvurunuz. / Please consult Hema Endüstri A.S.

SAE FLANŞLI DELİK ÖLÇÜLERİ / SAE FLANGE PORT DETAILS

SAE kod 61

SAE code 61

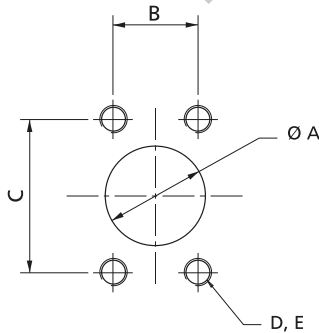

38.1	35.7	70.0	M12 x 1.75	26.9
(1.5000)	(1.406)	(2.756)	1/2"-13 UNC	(1.060)
63.5	50.8	88.9	M12 x 1.75	30.2
(2.5000)	(2.000)	(3.5000)	1/2"-13 UNC	(1.190)
76.2	61.9	106.4	M16 x 2.00	30.2
(3.000)	(2.437)	(4.189)	5/8"-11 UNC	(1.190)

**TABLO 1 : GİRİŞ DELİĞİ OPSİYONLARI / TABLE 1 - INLET PORT OPTIONS**

Delik Tipi Port Type	TEKLİ POMPA GİRİŞ DELİĞİ OPSİYONLARI SINGLE PUMP INLET PORT OPTIONS						ORTAK GİRİŞ DELİĞİ OPSİYONLARI COMMON INLET PORT OPTIONS							
	1			2			1				2			
Delik Tipi Port Type	SAE Flanş Metrik SAE Flange Metric			SAE Flanş UNC SAE Flange UNC			SAE Flanş Metrik SAE Flange Metric				SAE Flanş UNC SAE Flange UNC			
Delik Ölçü Kodu Port Size Code	K	L	M	K	L	M	K	L	M	N	K	L	M	
Delik Ölçüsü Port Size	2	2.1/2	3	2	2.1/2	3	2	2.1/2	3	4	2	2.1/2	3	4
R6100	<input type="checkbox"/>	<input checked="" type="checkbox"/>	<input type="checkbox"/>	<input type="checkbox"/>	<input checked="" type="checkbox"/>	<input type="checkbox"/>	<input type="checkbox"/>	<input checked="" type="checkbox"/>	<input type="checkbox"/>	<input type="checkbox"/>	<input type="checkbox"/>	<input checked="" type="checkbox"/>	<input type="checkbox"/>	<input type="checkbox"/>
R6117	<input type="checkbox"/>	<input checked="" type="checkbox"/>	<input type="checkbox"/>	<input type="checkbox"/>	<input checked="" type="checkbox"/>	<input type="checkbox"/>	<input type="checkbox"/>	<input checked="" type="checkbox"/>	<input type="checkbox"/>	<input type="checkbox"/>	<input type="checkbox"/>	<input checked="" type="checkbox"/>	<input type="checkbox"/>	<input type="checkbox"/>
R6137	<input type="checkbox"/>	<input checked="" type="checkbox"/>	<input type="checkbox"/>	<input type="checkbox"/>	<input checked="" type="checkbox"/>	<input type="checkbox"/>	<input type="checkbox"/>	<input checked="" type="checkbox"/>	<input type="checkbox"/>	<input type="checkbox"/>	<input type="checkbox"/>	<input checked="" type="checkbox"/>	<input type="checkbox"/>	<input type="checkbox"/>
R6160	<input type="checkbox"/>	<input checked="" type="checkbox"/>	<input type="checkbox"/>	<input type="checkbox"/>	<input checked="" type="checkbox"/>	<input type="checkbox"/>	<input type="checkbox"/>	<input checked="" type="checkbox"/>	<input type="checkbox"/>	<input type="checkbox"/>	<input type="checkbox"/>	<input checked="" type="checkbox"/>	<input type="checkbox"/>	<input type="checkbox"/>
R6187	<input type="checkbox"/>	<input checked="" type="checkbox"/>	<input type="checkbox"/>	<input type="checkbox"/>	<input checked="" type="checkbox"/>	<input type="checkbox"/>	<input type="checkbox"/>	<input checked="" type="checkbox"/>	<input type="checkbox"/>	<input type="checkbox"/>	<input type="checkbox"/>	<input checked="" type="checkbox"/>	<input type="checkbox"/>	<input type="checkbox"/>
R6220	<input type="checkbox"/>	<input checked="" type="checkbox"/>	<input type="checkbox"/>	<input type="checkbox"/>	<input checked="" type="checkbox"/>	<input type="checkbox"/>	<input type="checkbox"/>	<input checked="" type="checkbox"/>	<input type="checkbox"/>	<input type="checkbox"/>	<input type="checkbox"/>	<input checked="" type="checkbox"/>	<input type="checkbox"/>	<input type="checkbox"/>
S6083	<input type="checkbox"/>	<input checked="" type="checkbox"/>	<input type="checkbox"/>	<input type="checkbox"/>	<input checked="" type="checkbox"/>	<input type="checkbox"/>	<input type="checkbox"/>	<input checked="" type="checkbox"/>	<input type="checkbox"/>	<input type="checkbox"/>	<input type="checkbox"/>	<input checked="" type="checkbox"/>	<input type="checkbox"/>	<input type="checkbox"/>
S6097	<input type="checkbox"/>	<input checked="" type="checkbox"/>	<input type="checkbox"/>	<input type="checkbox"/>	<input checked="" type="checkbox"/>	<input type="checkbox"/>	<input type="checkbox"/>	<input checked="" type="checkbox"/>	<input type="checkbox"/>	<input type="checkbox"/>	<input type="checkbox"/>	<input checked="" type="checkbox"/>	<input type="checkbox"/>	<input type="checkbox"/>
S6113	<input type="checkbox"/>	<input checked="" type="checkbox"/>	<input type="checkbox"/>	<input type="checkbox"/>	<input checked="" type="checkbox"/>	<input type="checkbox"/>	<input type="checkbox"/>	<input checked="" type="checkbox"/>	<input type="checkbox"/>	<input type="checkbox"/>	<input type="checkbox"/>	<input checked="" type="checkbox"/>	<input type="checkbox"/>	<input type="checkbox"/>
S6132	<input type="checkbox"/>	<input checked="" type="checkbox"/>	<input type="checkbox"/>	<input type="checkbox"/>	<input checked="" type="checkbox"/>	<input type="checkbox"/>	<input type="checkbox"/>	<input checked="" type="checkbox"/>	<input type="checkbox"/>	<input type="checkbox"/>	<input type="checkbox"/>	<input checked="" type="checkbox"/>	<input type="checkbox"/>	<input type="checkbox"/>
S6155	<input type="checkbox"/>	<input checked="" type="checkbox"/>	<input type="checkbox"/>	<input type="checkbox"/>	<input checked="" type="checkbox"/>	<input type="checkbox"/>	<input type="checkbox"/>	<input checked="" type="checkbox"/>	<input type="checkbox"/>	<input type="checkbox"/>	<input type="checkbox"/>	<input checked="" type="checkbox"/>	<input type="checkbox"/>	<input type="checkbox"/>

Tercih edilen delik tipi  
Preferred port size

Tercih edilmeyen delik tipi  
Non-preferred port size

Not / Note :

Tek girişli çoklu pompaların model numarasını oluştururken, "2. giriş deliği tipi" için "0" ve "2. giriş deliği ölçüsü" için "X" kodunu kullanınız.

When coding, for single inlet multiple pumps, use '0' in '2nd inlet port type' and 'X' in '2nd inlet port size' in the model number.

**TABLO 2 : ÇIKIŞ DELİĞİ OPSİYONLARI / TABLE 2 - OUTLET PORT OPTIONS**

Delik Tipi Kodu Port Type Code	1					2				
	SAE Flanş Metrik SAE Flange Metric					SAE Flanş UNC SAE Flange UNC				
Delik Ölçü Kodu Port Size Code	A	B	D	F	H	A	B	D	F	H
Delik Ölçüsü Port Size	1/2	3/4	1	1.1/4	1.1/2	1/2	3/4	1	1.1/4	1.1/2
R6100	<input type="checkbox"/>	<input type="checkbox"/>	<input type="checkbox"/>	<input type="checkbox"/>	<input checked="" type="checkbox"/>	<input type="checkbox"/>	<input type="checkbox"/>	<input type="checkbox"/>	<input type="checkbox"/>	<input checked="" type="checkbox"/>
R6117	<input type="checkbox"/>	<input type="checkbox"/>	<input type="checkbox"/>	<input type="checkbox"/>	<input checked="" type="checkbox"/>	<input type="checkbox"/>	<input type="checkbox"/>	<input type="checkbox"/>	<input type="checkbox"/>	<input checked="" type="checkbox"/>
R6137	<input type="checkbox"/>	<input type="checkbox"/>	<input type="checkbox"/>	<input type="checkbox"/>	<input checked="" type="checkbox"/>	<input type="checkbox"/>	<input type="checkbox"/>	<input type="checkbox"/>	<input type="checkbox"/>	<input checked="" type="checkbox"/>
R6160	<input type="checkbox"/>	<input type="checkbox"/>	<input type="checkbox"/>	<input type="checkbox"/>	<input checked="" type="checkbox"/>	<input type="checkbox"/>	<input type="checkbox"/>	<input type="checkbox"/>	<input type="checkbox"/>	<input checked="" type="checkbox"/>
R6187	<input type="checkbox"/>	<input type="checkbox"/>	<input type="checkbox"/>	<input type="checkbox"/>	<input checked="" type="checkbox"/>	<input type="checkbox"/>	<input type="checkbox"/>	<input type="checkbox"/>	<input type="checkbox"/>	<input checked="" type="checkbox"/>
R6220	<input type="checkbox"/>	<input type="checkbox"/>	<input type="checkbox"/>	<input type="checkbox"/>	<input checked="" type="checkbox"/>	<input type="checkbox"/>	<input type="checkbox"/>	<input type="checkbox"/>	<input type="checkbox"/>	<input checked="" type="checkbox"/>
S6083	<input type="checkbox"/>	<input type="checkbox"/>	<input type="checkbox"/>	<input type="checkbox"/>	<input checked="" type="checkbox"/>	<input type="checkbox"/>	<input type="checkbox"/>	<input type="checkbox"/>	<input type="checkbox"/>	<input checked="" type="checkbox"/>
S6097	<input type="checkbox"/>	<input type="checkbox"/>	<input type="checkbox"/>	<input type="checkbox"/>	<input checked="" type="checkbox"/>	<input type="checkbox"/>	<input type="checkbox"/>	<input type="checkbox"/>	<input type="checkbox"/>	<input checked="" type="checkbox"/>
S6113	<input type="checkbox"/>	<input type="checkbox"/>	<input type="checkbox"/>	<input type="checkbox"/>	<input checked="" type="checkbox"/>	<input type="checkbox"/>	<input type="checkbox"/>	<input type="checkbox"/>	<input type="checkbox"/>	<input checked="" type="checkbox"/>
S6132	<input type="checkbox"/>	<input type="checkbox"/>	<input type="checkbox"/>	<input type="checkbox"/>	<input checked="" type="checkbox"/>	<input type="checkbox"/>	<input type="checkbox"/>	<input type="checkbox"/>	<input type="checkbox"/>	<input checked="" type="checkbox"/>
S6155	<input type="checkbox"/>	<input type="checkbox"/>	<input type="checkbox"/>	<input type="checkbox"/>	<input checked="" type="checkbox"/>	<input type="checkbox"/>	<input type="checkbox"/>	<input type="checkbox"/>	<input type="checkbox"/>	<input checked="" type="checkbox"/>

Tercih edilen delik tipi  
Preferred port size

Tercih edilmeyen delik tipi  
Non-preferred port size

Not / Note

Aşağıdaki çizimler saat yönü dönüşlü pompalarıdır. Saat yönünün tersi dönüşlü pompalarda giriş ve çıkış delikleri yer değişir. (Dönüş yönü tayini, tahrik mili tarafında bakışa göre dir.)

Drawings show clockwise rotation pumps. For anti-clockwise rotation pumps reverse the inlet and outlet port positions. (Rotation convention – view from pump shaft end).

**TEKLİ POMPALAR** - standart delikler  
**SINGLE PUMPS** - standard ports

Kod **A**  
Code

Örnek : S1A7155C51 **A** 1L1HC  
Example :

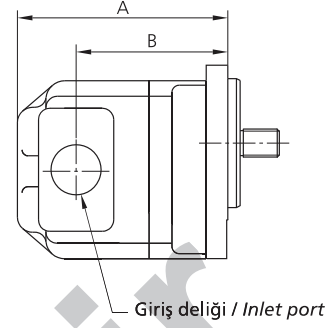
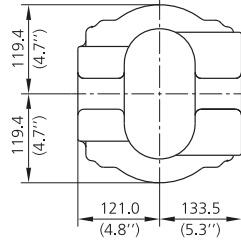
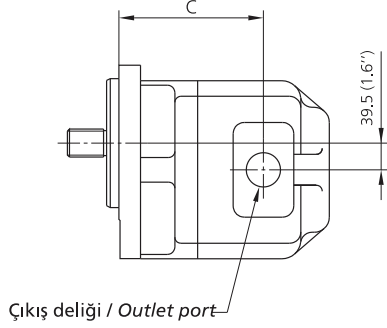

**İKİLİ POMPALAR** - 1 giriş / 2 çıkış  
**DOUBLE PUMPS** - 1 inlet / 2 outlets

Kod **A**  
Code

Örnek : S1A7155S7155T52 **A** 1M1H0X1HC  
Example :

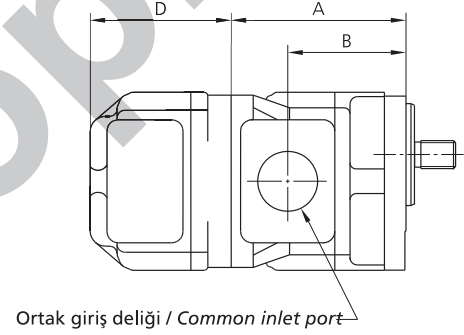
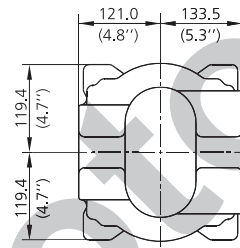
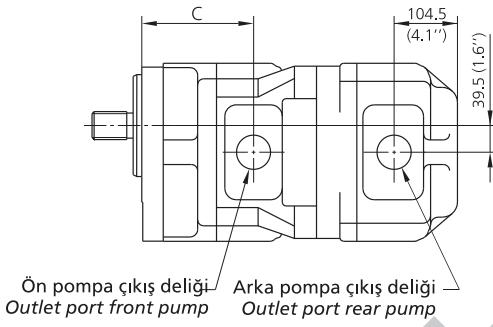

**İKİLİ POMPALAR** - 2 giriş / 2 çıkış  
**DOUBLE PUMPS** - 2 inlets / 2 outlets

Kod **B**  
Code

Örnek : S1A7155S7155T42 **B** 1L1H1L1HC  
Example :

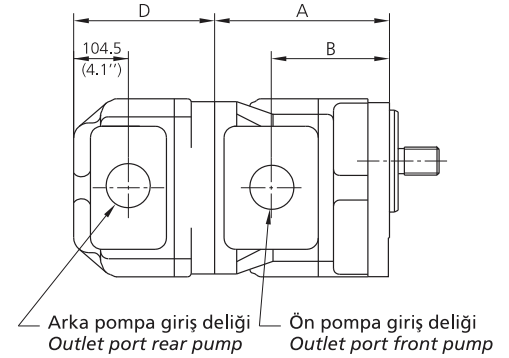
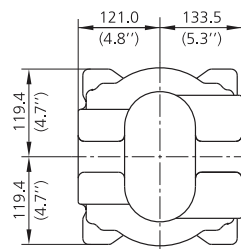
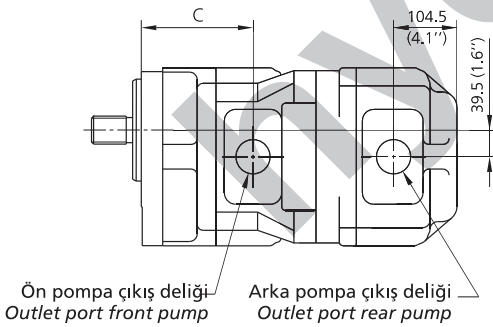

**ÜÇLÜ VE DÖRTLÜ POMPALAR** - 39. ve 40. sayfalara bakınız.  
**TRIPLE AND QUADRUPLE PUMPS** - See pages 39 and 40.



POMPA PUMP	A	B	C	D	AĞIRLIK WEIGHT kg (lb)		
	mm (in)	mm (in)	mm (in)	mm (in)	Tekli* Single	Ön* Front	Arka* Rear
S7155	288.0 (11.338)	183.0 (7.205)	183.0 (7.205)	•	79.0 (174.0)	84.0 (185.0)	67.0 (147.0)
S7180	296.0 (11.653)	191.0 (7.520)	191.0 (7.520)	•	82.0 (180.0)	87.0 (191.0)	70.0 (154.0)
S7208	305.0 (12.000)	201.0 (7.913)	201.0 (7.913)	•	86.0 (190.0)	91.0 (200.0)	74.0 (163.0)
S7248	318.0 (12.520)	214.0 (8.425)	214.0 (8.425)	•	91.0 (200.0)	96.0 (211.0)	79.0 (174.0)

• Hema Endüstri A.Ş ile temasa geçiniz. / Please contact Hema Endüstri

\*Not / Note :

Ağırlıklar yaklaşık değerlerdir.

İkili pompa ağırlığı = (ön pompa + arka pompa) ağırlıkları

Weights are approximate.

Double pump weight = (front + rear) weights

## PERFORMANS EĞRİSİ / PERFORMANCE DATA

ÇIKIŞ DEBİLERİ teorik değerlerdir. Genelde volümetrik verim %95'tan fazladır.

GİRİŞ GÜÇLERİ gerçek değerlerdir. Ortalama verim hesaba katılmıştır. Çıkış basıncı 50 bar'dan daha az olursa Hema Endüstri A.Ş'ye danışılmalıdır.

Örnek: S7208 pompası 1500 dev/dak'da, 302 lt/dak (80 USgal/dak) debi sağlar ve 200 bar (2900 psi) çıkış basıncında çalıştırmak için 118 kW (159 hp) güç gerekir.

OUTPUT FLOWS are theoretical. Generally volumetric efficiencies are in excess of 95%

INPUT POWERS are actual, taking into account average efficiencies. Please consult Hema Endüstri A.S. when output pressure is less than 50 bar.

Example: S7208 at 1500 rev/min gives output flow of 302 l/min (80 US gal/min) and requires 118 kW (159 hp) to drive it at 200 bar (2900 psi).

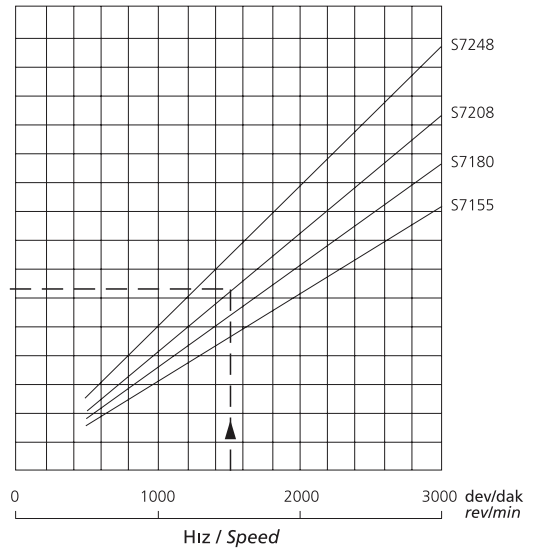
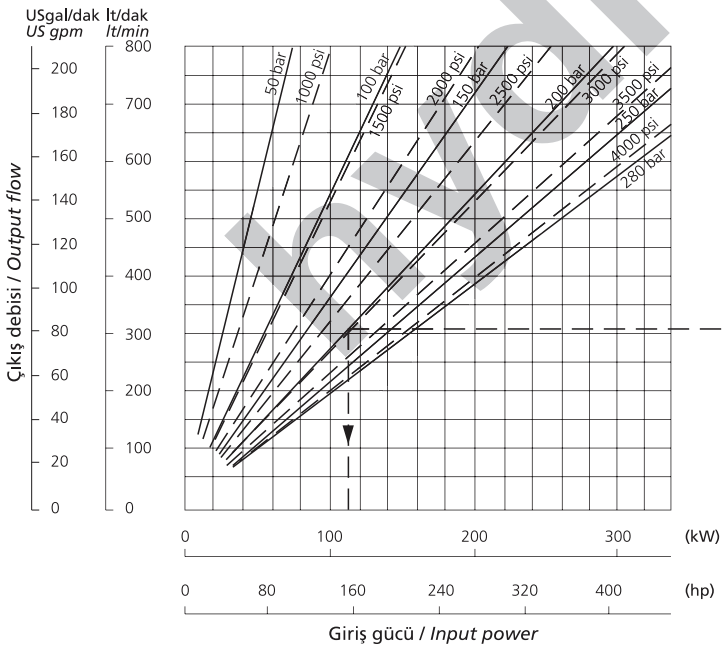

Eğriler 50°C (120°F)'de 23 cSt (110 SSU) yağ kullanılarak ortalama pompalar için çizilmiştir.

Curves drawn for average pumps at 50°C (120°F) - fluid viscosity 23 cSt (110 SSU).

## POMPA VERİMİ / PUMP EFFICIENCIES

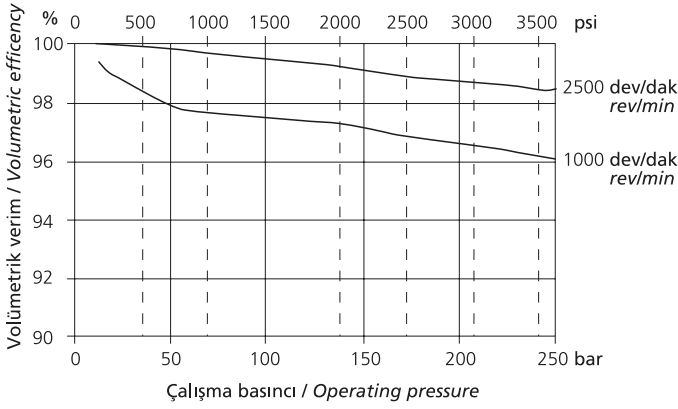

Bütün Q serisi pompalar çok yüksek verimlerde çalışır. Yandaki grafik 1000 ve 2500 dev/dak'da QS7 pompasının volümetrik verim eğrilerini gösterir.

All Q series pumps share very high efficiencies. The graph shows typical QS7 volumetric efficiency curves at 1000 and 2500 rev/min.

## GÜRÜLTÜ SEVİYESİ / NOISE LEVELS

6. sayfada belirtildiği gibi Q serisi pompaların geliştirilmesindeki en önemli faktör gürültü seviyesinin azaltılmasıdır. QR5 ve QS5 serisi pompaların, ISO 9614-4'e göre elde edilen, pompadan 1 metre uzaklıktaki ses basıncı seviyelerinin grafikleri aşağıda gösterilmiştir.

As described on page 6, the reduction of noise levels was a major factor in the development of the Q Series Pumps. The following graphs show QR5 and QS5 sound pressure levels at one meter from the pump obtained in accordance with ISO 9614-4.

## 1000 dev/dak'daki ses basıncı / Sound Pressure at 1000 rpm

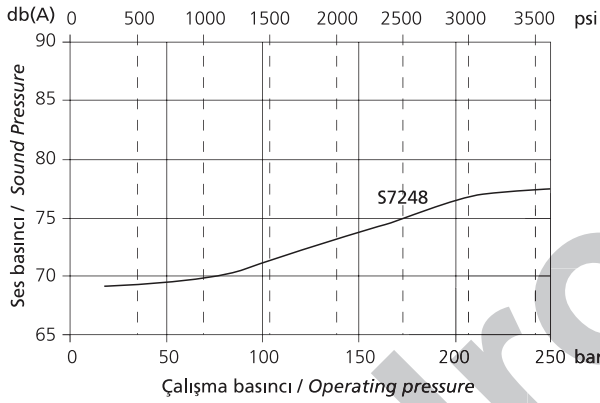

## 1500 dev/dak'daki ses basıncı / Sound Pressure at 1500 rpm

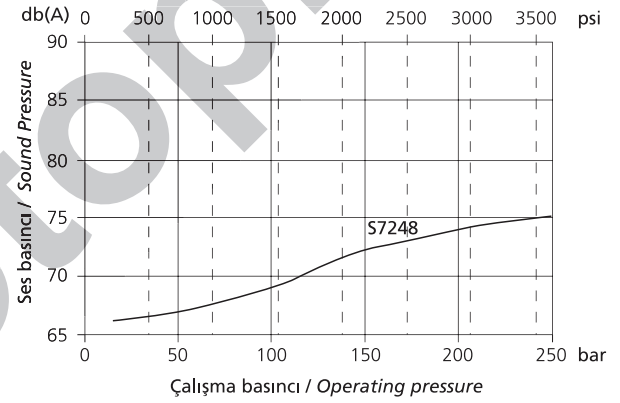

## 1800 dev/dak'daki ses basıncı / Sound Pressure at 1800 rpm

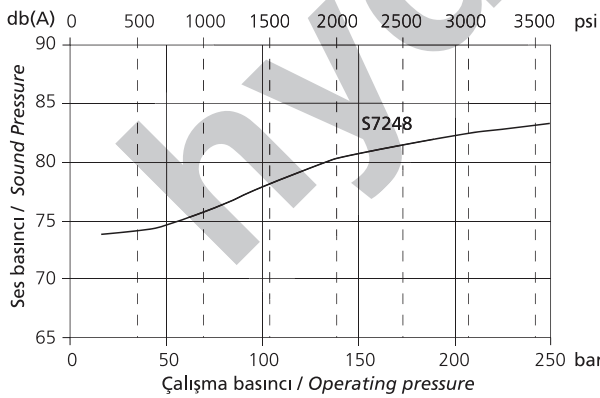

## 2250 dev/dak'daki ses basıncı / Sound Pressure at 2250 rpm

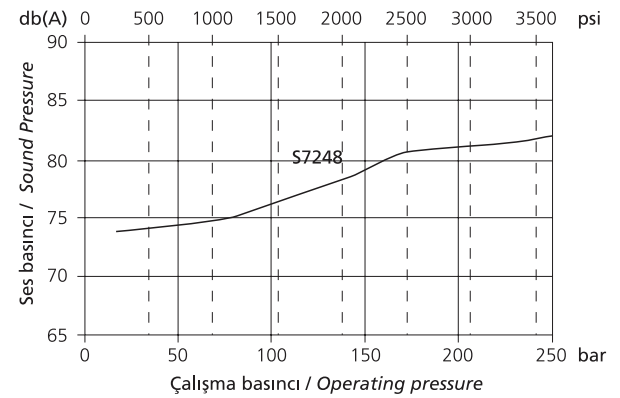

## EYLEMSİZLİK MOMENTİ / MOMENTS OF INERTIA

## QS7 SERİSİ / QS7 SERIES

POMPA TİPİ / PUMP SIZE		S7155	S7180	S7208	S7248
Eylemsizlik momenti Moment of Inertia	kg cm <sup>2</sup> (lb in <sup>2</sup> )	60.33 (20.51)	65.21 (22.17)	70.68 (24.03)	78.49 (26.69)

## ŞAFT KEÇELERİ / SHAFT SEALS

Kod **A** Dıştan tahrikler için şaft keçesi ve toz keçesi  
Code Shaft seal and wiper for external drives

Örnek : S1 **A** 7155C51A1L1HA  
Example :

Kod **C** Tork dönüştürücüsü ve dişli kutusu ile tahrik için kaçak kontrol delikli toz keçesi-keçe ve şaft keçesi.  
Code Shaft seal, wiper and seal with tell-tale hole for torque converter and gearbox drives. The tell-tale hole indicates leakage before mixing of fluids can occur.

Örnek : S1 **C** 7155C51A1L1HA  
Example :

## TAHRİK MİLLERİ / DRIVE SHAFTS

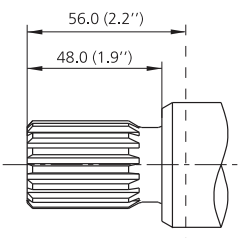
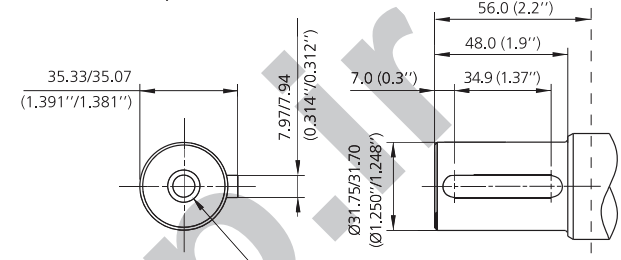
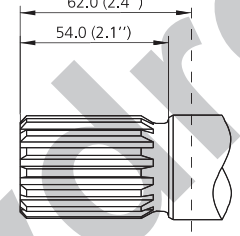
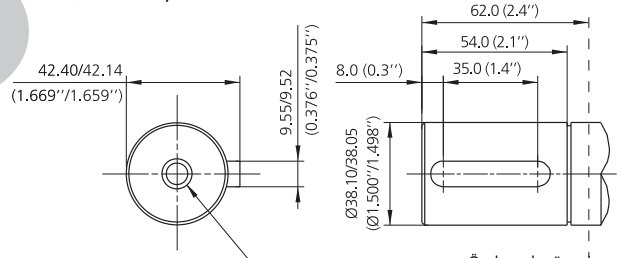
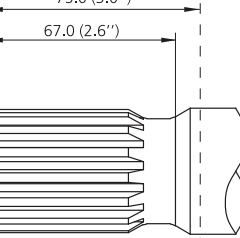
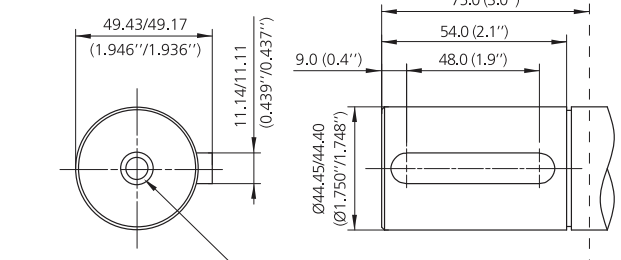
<p>Kod <b>C</b> SAE 32-4 (C) 1.1/4" spline Code Örnek : S1A7155 <b>C</b> 51A1L1HA Example</p> <p>Evolverent spline / Involute spline 14 Diş / 14 Teeth 12/24 DP Diş dibi düz / Flat root Yanaktan alıştırma / Side fit 30° kavrama açısı / 30° pressure angle Diş üstü çapı / Major Dia: 31.22/31.12 (1.229"/1.225")</p>  <p>Ön kapak yüzeyi Standard flange mounting face</p> <p><math>p \times D = 45565</math> (bar x cm<sup>3</sup>/dev)* (bar x cm<sup>3</sup>/rev)</p> <p><math>p \times D = 40325</math> (psi x in<sup>3</sup>/dev)* (psi x in<sup>3</sup>/rev)</p>	<p>Kod <b>G</b> SAE 32-1 (C) 1.1/4" paralel / parallel Code Örnek : S1A7155 <b>G</b> 51A1L1HA Example :</p>  <p>Ön kapak yüzeyi Standard flange mounting face</p> <p><math>p \times D = 45565</math> (bar x cm<sup>3</sup>/dev)* (bar x cm<sup>3</sup>/rev)</p> <p><math>p \times D = 40325</math> (psi x in<sup>3</sup>/dev)* (psi x in<sup>3</sup>/rev)</p> <p>3/8"-24UNF x 19.0 (0.75")</p>
<p>Kod <b>T</b> SAE 38-4 (CC) 1.1/2" spline Code Örnek : S1A7155 <b>T</b> 51A1L1HA Example</p> <p>Evolverent spline / Involute spline 17 Diş / 17 Teeth 12/24 DP Diş dibi düz / Flat root Yanaktan alıştırma / Side fit 30° kavrama açısı / 30° pressure angle Diş üstü çapı / Major Dia: 37.57/37.44 (1.479"/1.474")</p>  <p>Ön kapak yüzeyi Standard flange mounting face</p> <p><math>p \times D = 86950</math> (bar x cm<sup>3</sup>/dev)* (bar x cm<sup>3</sup>/rev)</p> <p><math>p \times D = 76950</math> (psi x in<sup>3</sup>/dev)* (psi x in<sup>3</sup>/rev)</p>	<p>Kod <b>N</b> SAE 38-1 (CC) 1.1/2" paralel / parallel Code Örnek : S1A7155 <b>N</b> 51A1L1HA Example :</p>  <p>Ön kapak yüzeyi Standard flange mounting face</p> <p><math>p \times D = 86950</math> (bar x cm<sup>3</sup>/dev)* (bar x cm<sup>3</sup>/rev)</p> <p><math>p \times D = 76950</math> (psi x in<sup>3</sup>/dev)* (psi x in<sup>3</sup>/rev)</p> <p>3/8"-24UNF x 19.0 (0.75")</p>
<p>Kod <b>D</b> SAE 44-4 (D) 1.3/4" spline Code Örnek : S1A7155 <b>D</b> 51A1L1HA Example</p> <p>Evolverent spline / Involute spline 13 Diş / 13 Teeth 8/16 DP Diş dibi düz / Flat root Yanaktan alıştırma / Side fit 30° kavrama açısı / 30° pressure angle Diş üstü çapı / Major Dia: 43.71/43.59 (1.721"/1.716")</p>  <p>Ön kapak yüzeyi Standard flange mounting face</p> <p><math>p \times D = 121400</math> (bar x cm<sup>3</sup>/dev)* (bar x cm<sup>3</sup>/rev)</p> <p><math>p \times D = 107439</math> (psi x in<sup>3</sup>/dev)* (psi x in<sup>3</sup>/rev)</p>	<p>Kod <b>P</b> SAE 44-1 (D) 1.3/4" paralel / parallel Code Örnek : S1A7155 <b>P</b> 51A1L1HA Example :</p>  <p>Ön kapak yüzeyi Standard flange mounting face</p> <p><math>p \times D = 121400</math> (bar x cm<sup>3</sup>/dev)* (bar x cm<sup>3</sup>/rev)</p> <p><math>p \times D = 107439</math> (psi x in<sup>3</sup>/dev)* (psi x in<sup>3</sup>/rev)</p> <p>3/8"-24UNF x 19.0 (0.75")</p>

\* p=basınç, D=iletim hacmi. Belirtilen değerler aşılmamalıdır.  
Not: Çoklu pompalarda, p x D değerlerinin toplamı belirtilen değeri aşmamalıdır. Sayfa 39'a bakınız.

\* p = pressure, D = displacement. The stated values must not be exceeded.  
Note: For multiple pumps the sum of the p x D values must not exceed the stated value. See Page 39.

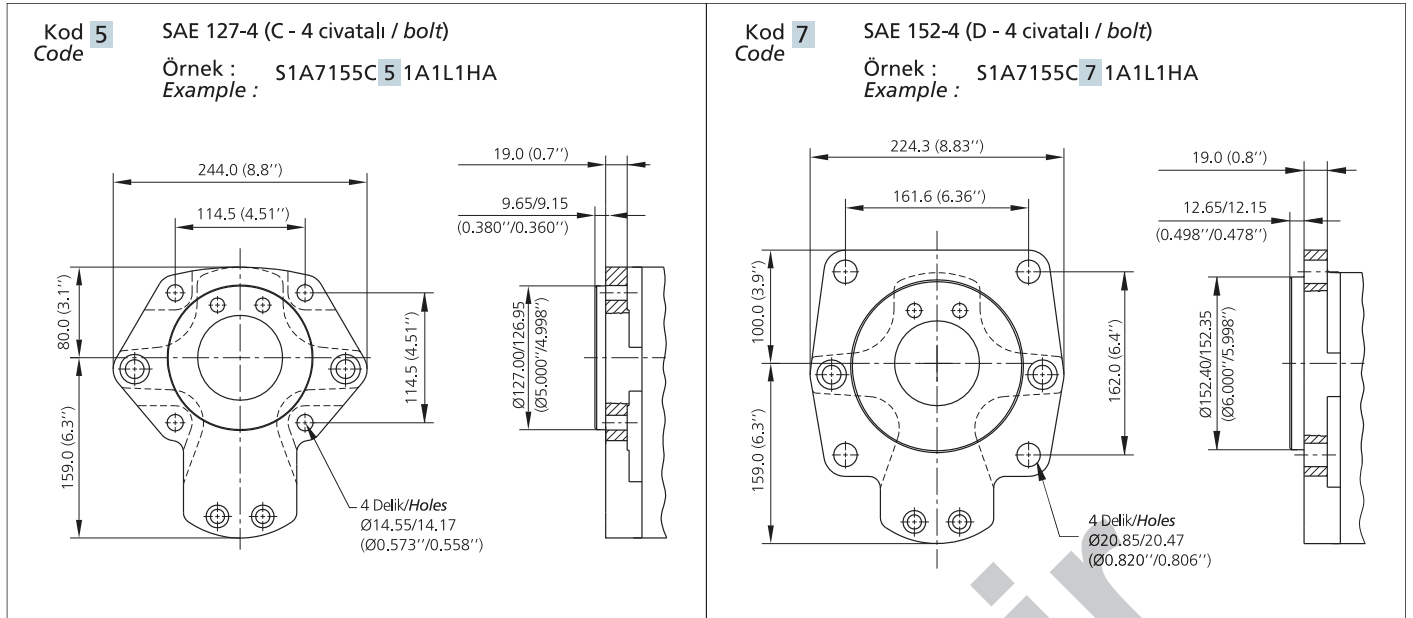

POMPA SAYISI VE GİRİŞ DELİĞİ KONUMLARI / NUMBER OF PUMP SECTIONS AND INLET PORT POSITIONS

Kod **A**  
Code

Şekil / Fig 1

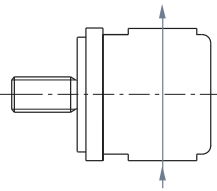

TEKLİ POMPA / SINGLE PUMP

Örnek / Example

**S1A7248T51A1M1KC**

**1** Pompa sayısı / Number of pump sections

**A** Giriş deliği konumu - şekil-1'e bakın / Inlet port position - see fig 1

**1** Giriş deliği tipi - tablo 1'e bakın / Inlet port type - see table 1

**M** Giriş deliği ölçüleri - tablo 1'e bakın / Inlet port size - see table 1

**1** Çıkış deliği tipi - tablo 2'ye bakın / Outlet port type - see table 2

**K** Çıkış deliği ölçüleri - tablo 2'ye bakın / Outlet port size - see table 2

**C** Dönüş yönü - Tahrik mili tarafında bakışa göre / Rotation - viewed from shaft

Kod **C**  
Code

Şekil / Fig 2

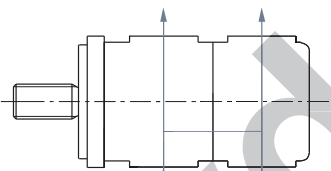

İKİLİ VEYA DUAL POMPA / MULTI PUMP

Örnek / Example

**S1A7208S7180T52B1M1K1L1HC**

**2** Pompa sayısı / Number of pump sections

**B** Giriş deliği konumu - şekil-2 veya 3'e bakın / Inlet port position - see figs 2 or 3

**1** 1. Giriş deliği tipi - tablo 1'e bakın / 1st Inlet port type - see table 1

**M** 1. Giriş deliği ölçüleri - tablo 1'e bakın / 1st Inlet port size - see table 1

**1** 1. Çıkış deliği tipi - tablo 2'ye bakın / 1st Outlet port type - see table 2

**K** 1. Çıkış deliği ölçüleri - tablo 2'ye bakın / 1st Outlet port size - see table 2

**1** 2. Giriş deliği tipi - tablo 1'e bakın / 2nd Inlet port type - see table 1

**L** 2. Giriş deliği ölçüleri - tablo 1'e bakın / 2nd Inlet port size - see table 1

**1** 2. Çıkış deliği tipi - tablo 2'ye bakın / 2nd Outlet port type - see table 2

**H** 2. Çıkış deliği ölçüleri - tablo 2'ye bakın / 2nd Outlet port size - see table 2

**C** Dönüş yönü - Tahrik mili tarafında bakışa göre / Rotation - viewed from shaft

Kod **A**  
Code

Şekil / Fig 3

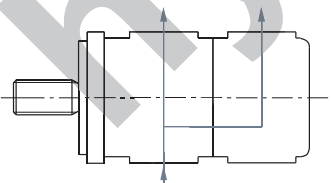

## ÇOKLU POMPALAR / MULTIPLE PUMPS

Hema Endüstri A.Ş.'ye başvurunuz. / Please consult Hema Endüstri A.S.

## SAE FLANŞLI DELİK ÖLÇÜLERİ / SAE FLANGE PORT DETAILS

SAE kod 61

SAE code 61

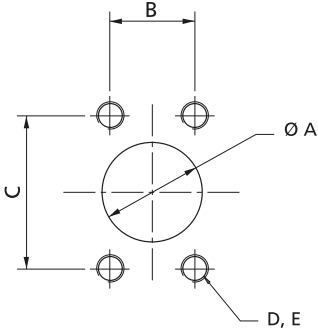

SAE FLANŞ ÖLÇÜSÜ SAE FLANGE SIZE	A mm (in)	B mm (in)	C mm (in)	D	E Derinlik Depth mm (in)
1.1/2"	38.1 (1.500)	35.71 (1.406)	69.85 (2.750)	M12 x 1.75 1/2"-13 UNC	26.9 (1.06)
	50.8 (2.000)	42.88 (1.688)	77.77 (3.062)	M12 x 1.75 1/2"-13 UNC	26.9 (1.06)
2.1/2"	63.5 (2.500)	50.80 (2.000)	88.90 (3.500)	M12 x 1.75 1/2"-13 UNC	30.2 (1.19)
	76.2 (3.000)	61.93 (2.438)	106.38 (4.188)	M16 x 2.00 5/8"-11 UNC	30.2 (1.19)

TABLO 1 : GİRİŞ DELİĞİ OPSİYONLARI / TABLE 1 - INLET PORT OPTIONS

Delik Tipi Port Type	TEKLİ POMPA GİRİŞ DELİĞİ OPSİYONLARI SINGLE PUMP INLET PORT OPTIONS								ORTAK GİRİŞ DELİĞİ OPSİYONLARI COMMON INLET PORT OPTIONS							
	1				2				1				2			
Delik Tipi Kodu Port Type Code	SAE Flanş Metrik SAE Flange Metric				SAE Flanş UNC SAE Flange UNC				SAE Flanş Metrik SAE Flange Metric				SAE Flanş UNC SAE Flange UNC			
Delik Ölçü Kodu Port Size Code	H	K	L	M	H	K	L	M	K	L	M	N	K	L	M	N
Delik Ölçüsü Port Size	1.1/2	2	2.1/2	3	1.1/2	2	2.1/2	3	2	2.1/2	3	4	2	2.1/2	3	4
S7155	<input type="checkbox"/>	<input type="checkbox"/>	<input checked="" type="checkbox"/>	<input type="checkbox"/>	<input type="checkbox"/>	<input type="checkbox"/>	<input checked="" type="checkbox"/>	<input type="checkbox"/>	<input type="checkbox"/>	<input type="checkbox"/>	<input checked="" type="checkbox"/>	<input type="checkbox"/>	<input type="checkbox"/>	<input type="checkbox"/>	<input checked="" type="checkbox"/>	<input type="checkbox"/>
S7180	<input type="checkbox"/>	<input type="checkbox"/>	<input checked="" type="checkbox"/>	<input type="checkbox"/>	<input type="checkbox"/>	<input type="checkbox"/>	<input checked="" type="checkbox"/>	<input type="checkbox"/>	<input type="checkbox"/>	<input type="checkbox"/>	<input checked="" type="checkbox"/>	<input type="checkbox"/>	<input type="checkbox"/>	<input type="checkbox"/>	<input checked="" type="checkbox"/>	<input type="checkbox"/>
S7208	<input type="checkbox"/>	<input type="checkbox"/>	<input type="checkbox"/>	<input checked="" type="checkbox"/>	<input type="checkbox"/>	<input type="checkbox"/>	<input type="checkbox"/>	<input checked="" type="checkbox"/>	<input type="checkbox"/>	<input type="checkbox"/>	<input checked="" type="checkbox"/>	<input type="checkbox"/>	<input type="checkbox"/>	<input type="checkbox"/>	<input checked="" type="checkbox"/>	<input type="checkbox"/>
S7248	<input type="checkbox"/>	<input type="checkbox"/>	<input type="checkbox"/>	<input checked="" type="checkbox"/>	<input type="checkbox"/>	<input type="checkbox"/>	<input type="checkbox"/>	<input checked="" type="checkbox"/>	<input type="checkbox"/>	<input type="checkbox"/>	<input checked="" type="checkbox"/>	<input type="checkbox"/>	<input type="checkbox"/>	<input type="checkbox"/>	<input checked="" type="checkbox"/>	<input type="checkbox"/>

Tercih edilen delik tipi  
Preferred port size

Tercih edilmeyen delik tipi  
Non-preferred port size

Not / Note :

Tek girişli çoklu pompaların model numarasını oluştururken, "2. giriş deliği tipi" için "0" ve "2. giriş deliği ölçüsü" için "X" kodunu kullanınız.

When coding, for single inlet multiple pumps, use '0' in 2nd inlet port type' and 'X' in '2nd inlet port size' in the model number.

TABLO 2 : ÇIKIŞ DELİĞİ OPSİYONLARI / TABLE 2 - OUTLET PORT OPTIONS

Delik Tipi Kodu Port Type Code	1						2					
	SAE Flanş Metrik SAE Flange Metric						SAE Flanş UNC SAE Flange UNC					
Delik Ölçü Kodu Port Size Code	A	B	D	F	H	K	A	B	D	F	H	K
Delik Ölçüsü Port Size	1/2	3/4	1	1.1/4	1.1/2	2	1/2	3/4	1	1.1/4	1.1/2	2
S7155	<input type="checkbox"/>	<input type="checkbox"/>	<input type="checkbox"/>	<input type="checkbox"/>	<input checked="" type="checkbox"/>	<input type="checkbox"/>	<input type="checkbox"/>	<input type="checkbox"/>	<input type="checkbox"/>	<input type="checkbox"/>	<input checked="" type="checkbox"/>	<input type="checkbox"/>
S7180	<input type="checkbox"/>	<input type="checkbox"/>	<input type="checkbox"/>	<input type="checkbox"/>	<input checked="" type="checkbox"/>	<input type="checkbox"/>	<input type="checkbox"/>	<input type="checkbox"/>	<input type="checkbox"/>	<input type="checkbox"/>	<input checked="" type="checkbox"/>	<input type="checkbox"/>
S7208	<input type="checkbox"/>	<input type="checkbox"/>	<input type="checkbox"/>	<input type="checkbox"/>	<input type="checkbox"/>	<input checked="" type="checkbox"/>	<input type="checkbox"/>	<input type="checkbox"/>	<input type="checkbox"/>	<input type="checkbox"/>	<input type="checkbox"/>	<input checked="" type="checkbox"/>
S7248	<input type="checkbox"/>	<input type="checkbox"/>	<input type="checkbox"/>	<input type="checkbox"/>	<input type="checkbox"/>	<input checked="" type="checkbox"/>	<input type="checkbox"/>	<input type="checkbox"/>	<input type="checkbox"/>	<input type="checkbox"/>	<input type="checkbox"/>	<input checked="" type="checkbox"/>

Tercih edilen delik tipi  
Preferred port size

Tercih edilmeyen delik tipi  
Non-preferred port size

Aynı ya da farklı tipteki R ve S serisi pompalar beraber bağlanarak, aynı tahrik mili ile tahrik edilecek şekilde çoklu pompalar (ikili, üçlü, hatta dördlü) oluşturulabilir.

AYRICA R VE S SERİSİ POMPALARA ALÜMİNYUM GÖVDELİ POMPALAR DA BAĞLAMAK MÜMKÜNDÜR. AYRINTILAR İÇİN LÜTFEN HEMA ENDÜSTRİ A.Ş.' YE BAŞVURUNUZ.

Çoklu pompa kombinasyonları, tahrik mili ve kaplinlerin tork kapasitesi ile sınırlıdır. Aşağıda belirtilen tork faktörleri aşılmamalıdır.

Tork faktörü  $T = pD$ ,  $p$  = çıkış basıncı,  $D$  = iletim hacmi.

Örneğin üçlü pompalar için;  
For a triple pump, for

$$T_{\text{tahrik mili/shaft}} = p_1 D_1 + p_2 D_2 + p_3 D_3$$

$$T_{\text{kaplin/coupling 1}} = p_2 D_2 + p_3 D_3$$

$$= p_3 D_3$$

( $p_1$ ,  $p_2$  ve  $p_3$  maksimum eş zamanlı basınçlardır.)  
( $p_1$ ,  $p_2$  and  $p_3$  are maximum simultaneous pressures.)

Both R Series and S Series pumps of the same or different frame sizes may be connected together to form multiple (double, triple or even quadruple) pumps driven by the same shaft.

IT IS ALSO POSSIBLE TO MOUNT ALUMINIUM PUMPS TO "R" AND "S" SERIES PUMPS. PLEASE CONSULT HEMA ENDUSTRI A.S.

Torque factor  $T = pD$  where  $p$  = outlet pressure,  $D$  =

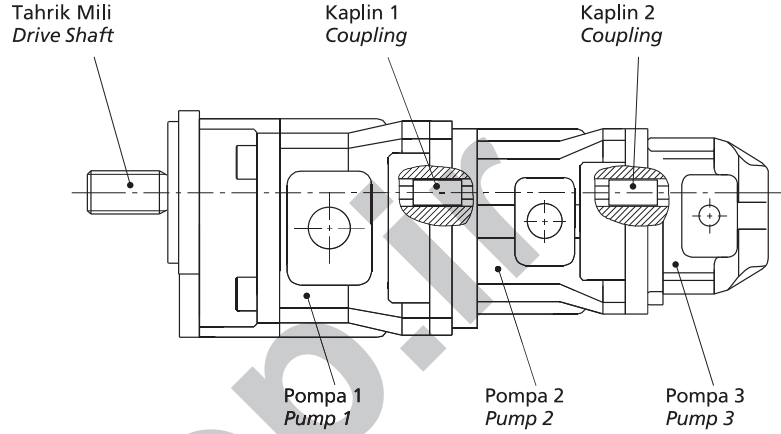

T değeri aşağıdaki değerleri aşmamalıdır. / The T values must not exceed those shown in the table

KOD COD	TAHRİK MİLİ TİPİ SHAFT TYPE	T = pD MAKSİMUM / MAXIMUM	
		bar x cm <sup>3</sup> /dev bar x cm <sup>3</sup> /rev	psi x in <sup>3</sup> /dev psi x
A	SAE 'A' 5/8" spline	5200	4600
E	SAE 'A' 5/8" paralel/parallel	5200	4600
B	SAE 'B' 7/8" spline	14226	12590
F	SAE 'B' 7/8" paralel/parallel	14226	12590
Q	SAE 'BB' 1" spline	22450	19869
H	SAE 'BB' 1" paralel/parallel	22450	19869
C	SAE 'C' 1.1/4" spline	45565	40325
G	SAE 'C' 1.1/4" paralel/parallel	45565	40325
T	SAE 'CC' 1.1/2" spline	86950	76950
N	SAE 'CC' 1.1/2" paralel/parallel	86950	76950
D	SAE 'D' 1.3/4" spine	121400	107439
P	SAE 'D' 1.3/4" paralel/parallel	121400	107439
	Kaplin/Coupling Q4-Q4	11250	9956
	Kaplin/Coupling Q5-Q4	11250	9956
	Kaplin/Coupling Q5-Q5	21250	18806
	Kaplin/Coupling Q6-Q4	11250	9956
	Kaplin/Coupling Q6-Q5	21250	18806
	Kaplin/Coupling Q6-Q6	40000	35400
	Kaplin/Coupling Q7-Q4	11250	9956
	Kaplin/Coupling Q7-Q5	21250	18806
	Kaplin/Coupling Q7-Q6	40000	35400
	Kaplin/Coupling Q7-Q7	62000	54870

Aşağıdaki resimler, QR ve QS serisi pompaların boyutları hakkında hızlı bilgi verir. Çoklu pompalar, tekli pompaların bağlanması şeklinde gösterilmiştir. Dual gövde tipi gösterilmemiştir.

These drawings give a quick reference to the overall dimensions of the QR or QS series pumps. Multiple pumps are shown made up of individual sections connected together. The 'dual' type housing is not depicted.

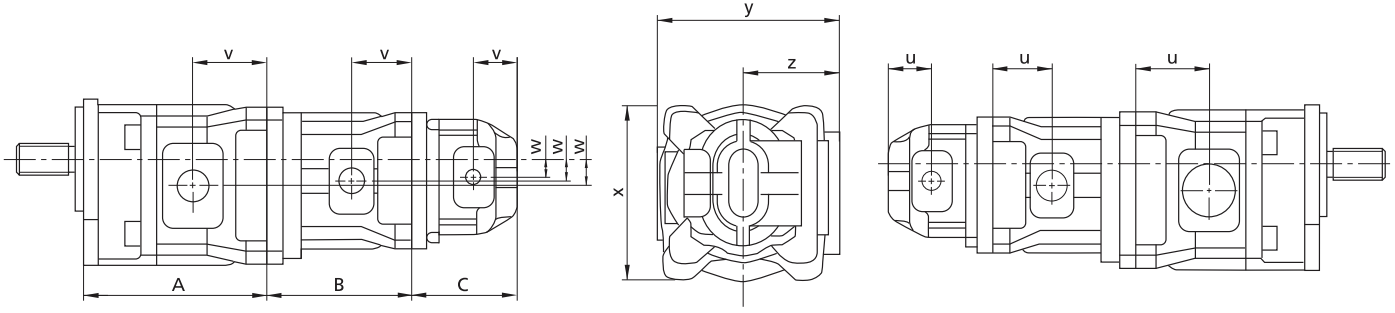

	U (girişler / inlets)		U (çıkışlar / outlets)		W		X		Y		Z	
	mm	in	mm	in	mm	in	mm	in	mm	in	mm	in
QR4 / QS4	46.0	1.81	53.0	2.09	21.0	0.83	140.0	5.51	130.0	5.12	65.0	2.56
QR5 / QS5	54.5	2.15	72.5	2.85	26.0	1.02	166.0	6.53	180.0	7.09	94.0	3.70
QR6 / QS6	68.6	2.70	90.1	3.55	32.0	1.26	196.0	7.72	201.0	7.91	107.0	4.21
QS7	104.5	4.11	104.5	4.11	39.5	1.56	239.0	9.41	254.5	10.02	133.5	5.26

Pompa boyu :

Pump lengths :

Tekli = A

Single = A

İkili = A + C

Double = A + C

Üçlü = A + B + C

Triple = A + B + C

R SERİSİ SERIE	A		B		C	
	mm	in	mm	in	mm	in
R4016	145.0	5.71	115.0	4.53	115.0	4.53
R4019	147.0	5.79	118.0	4.65	118.0	4.65
R4023	150.0	5.91	121.0	4.76	121.0	4.76
R4027	154.0	6.06	124.0	4.88	124.0	4.88
R4032	158.0	6.22	128.0	5.04	128.0	5.04
R4038	163.0	6.42	133.0	5.24	133.0	5.24
R4045	169.0	6.65	139.0	5.47	139.0	5.47
R4053	175.0	6.89	146.0	5.75	146.0	5.75
R4060	181.0	7.12	151.0	5.95	151.0	5.94
R5045	178.0	7.01	144.0	5.67	144.0	5.67
R5053	182.0	7.16	148.0	5.83	148.0	5.83
R5063	187.0	7.36	154.0	6.06	154.0	6.06
R5073	193.0	7.60	159.0	6.26	159.0	6.26
R5085	199.0	7.83	166.0	6.53	166.0	6.35
R5100	207.0	8.15	174.0	6.85	174.0	6.85
R5120	218.0	8.58	185.0	7.28	185.0	7.28
R6100	220.0	8.66	182.0	7.16	182.0	7.16
R6117	226.0	8.90	188.0	7.40	188.0	7.40
R6137	233.0	9.17	195.0	7.68	195.0	7.68
R6160	241.0	9.49	203.0	7.99	203.0	7.99
R6187	251.0	9.88	213.0	8.39	213.0	8.38
R6220	263.0	10.35	225.0	8.86	225.0	8.86

• Lütfen Hema Endüstri A.Ş. başvurunuz.

Not : Q4, Q6'ya bağlanırsa, B ve C ölçülerine 18mm eklenir.

S SERİSİ SERIE	A		B		C	
	mm	in	mm	in	mm	in
S4016	151.0	5.94	121.0	4.76	121.0	4.76
S4023	158.0	6.22	129.0	5.08	129.0	5.08
S4027	163.0	6.42	134.0	5.27	134.0	5.27
S4032	169.0	6.65	139.0	5.47	139.0	5.47
S4037	175.0	6.89	145.0	5.71	145.0	5.71
S4042	181.0	7.12	151.0	5.94	151.0	5.94
S5045	188.0	7.40	154.0	6.06	154.0	6.06
S5051	192.0	7.56	159.0	6.26	159.0	6.26
S5060	199.0	7.83	166.0	6.53	166.0	6.53
S5070	207.0	8.15	173.0	6.81	173.0	6.81
S5085	218.0	8.58	185.0	7.28	185.0	7.28
S6083	226.0	8.90	188.0	7.40	188.0	7.40
S6097	234.0	9.21	196.0	7.72	196.0	7.72
S6113	242.0	9.53	204.0	8.03	204.0	8.03
S6132	251.0	9.88	213.0	8.38	213.0	8.39
S6155	263.0	10.35	225.0	8.86	225.0	8.86
S7155	•	•	•	•	•	•
S7180	•	•	•	•	•	•
S7208	•	•	•	•	•	•
S7248	•	•	•	•	•	•

• Please consult Hema Endüstri A.Ş.

Note : When mounting Q4 to Q6 add 18mm to dimensions B and C.

hydrotop.ir

**H-EMA**  
ENDÜSTRİ A.Ş.

**MERKEZ / Head Office**

Büyükdere Cad. Üçyol Mevkii No. 53 80670 Maslak İST. / TURKEY  
Phone : +90 (0212) 285 22 40 Fax : +90 (0212) 286 44 55

**Fabrika / Factory**

Organize Sanayi Bölgesi 59501 Çerkezköy / TEKİRDAĞ / TURKEY  
Phone : +90 (282) 758 10 40 Fax : +90 (282) 758 10 90

**HATTAT**  
OTOMOTİV PAZARLAMA A.Ş.

Yurt İçi Yedek Parça ve Servis Şirketi  
Domestic Sales and Service Company

**İRTİBAT / Contact**

Büyükdere Cad. Üçyol Mevkii No. 53 80670 Maslak İST. / TURKEY  
Phone : +90 (0212) 285 22 40 Fax : +90 (0212) 286 44 55

**MERKEZ / Head Office**

Organize Sanayi Bölgesi 59501 Çerkezköy / TEKİRDAĞ / TURKEY  
Phone : +90 (282) 758 10 40 Fax : +90 (282) 758 10 68