

Oil Removal Filter

F74 * - * * * - * * *

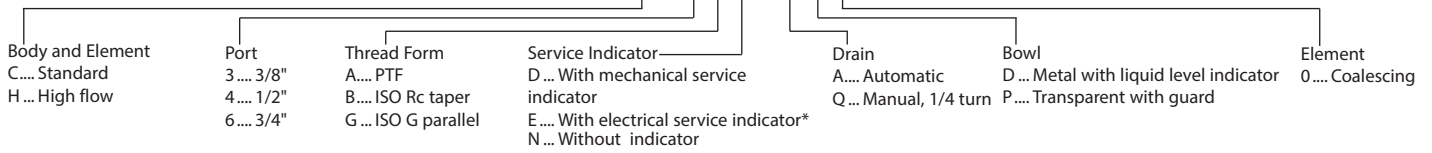

* See Norgren publication IM-900.920 for specifications and electrical wire connections of the optional electric service indicator.

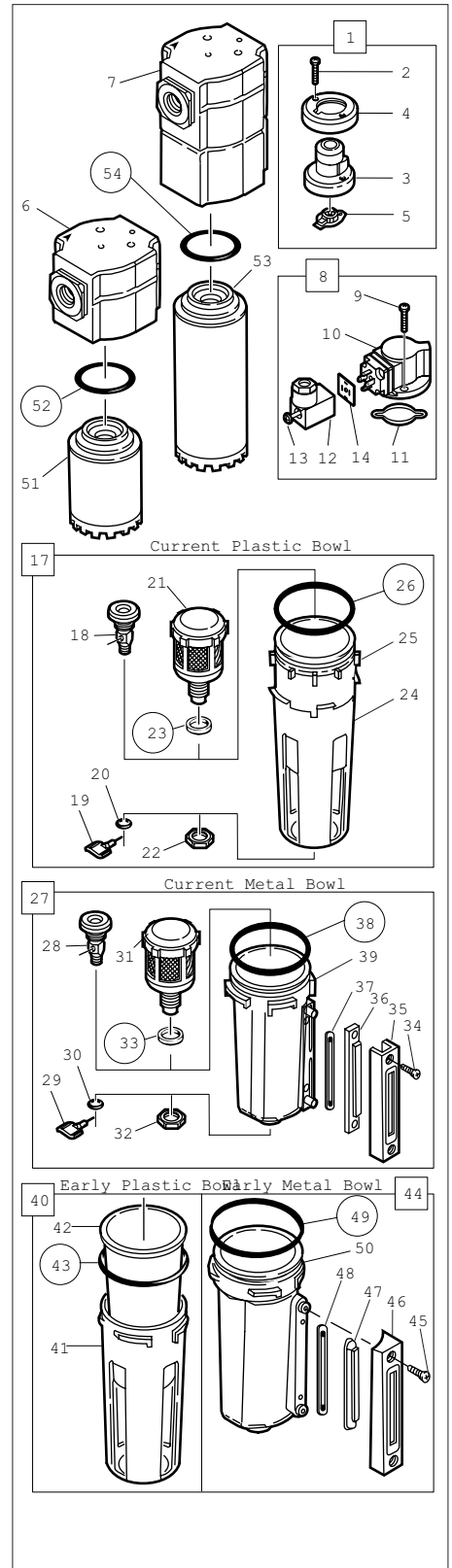

TECHNICAL DATA

Fluid: Compressed air

Maximum pressure:

Transparent bowl: 10 bar (150 psig)

Metal bowl: 17 bar (250 psig)

Operating temperature*:

Transparent bowl: -20° to +50°C (0° to +125°F)

Metal bowl: -20° to +65°C (0° to +150°F)

* Air supply must be dry enough to avoid ice formation at temperatures below +2°C (+35°F).

Particle removal: Down to 0,01 µm

Air quality: Within ISO 8573-1, Class 1 (particulates) and Class 2 (oil content)

Maximum remaining oil content in outlet air: 0,01 ppm at

+20°C (+70°F) with an inlet concentration of 17 ppm

Maximum flow at 6,3 bar (90 psig) inlet pressure to

maintain stated oil removal performance:

F74C: 16 dm³/s (33.9 scfm)

F74H: 28 dm³/s (59.3 scfm)

Nominal bowl size: 0,2 litre (7 fluid ounce)

Manual drain connection: 1/8"

Automatic drain connection: 1/8"

Automatic drain operating conditions (float operated):

Bowl pressure required to close drain: Greater than 0,3 bar (5 psig)

Bowl pressure required to open drain: Less than 0,2 bar (3 psig)

Minimum air flow required to close drain:

1 dm³/s (2 scfm)

Manual operation: Depress pin inside drain outlet to drain bowl

Materials:

Body: Aluminum

Bowl:

Transparent with guard: Polycarbonate, steel guard

Metal: Aluminum

Metal bowl liquid level indicator lens: Transparent nylon

Element: Synthetic fibre and polyurethane foam

Elastomers: Neoprene and nitrile

Mechanical service indicator materials:

Body: Transparent nylon

Internal parts: Acetal

Spring: Stainless steel

Elastomers: Nitrile

REPLACEMENT ITEMS

Service kit (includes items

circled on exploded view) 4380-730

Liquid level lens kit (34, 36, 37, 38)..... 4380-050

Filter element:

F74C (51, 52) 4344-01

F74H (53, 54)..... 4344-02

Manual drain (18, 19, 20) (28, 29, 30)..... 619-50

Automatic drain (21, 22, 23) (31, 32, 33):

1/8 NPT outlet 3000-10

G 1/8 outlet 3000-97

Mechanical service Indicator (1)..... 5797-50

Electrical service Indicator (8)..... 4020-51R

INSTALLATION

1. Shut-off air pressure. Install filter in air line -

1 vertically (bowl down),

1 with air flow in direction of arrow on body,

1 upstream of regulators, lubricators, and cycling valves,

1 as close as possible to the air supply when used as a main line filter,

1 as close as possible to the device being serviced when used as a final filter.

2. Connect piping to proper ports using pipe thread sealant on male threads only. Do not allow sealant to enter interior of unit.

3. Flexible tube with 3mm (0.125") minimum I.D. can be connected to the automatic drain. Avoid restrictions in the tube.

4. Push bowl, or bowl with guard, into body and turn fully clockwise before pressurizing.

5. Install a Norgren general purpose filter with a 5 µm element upstream of the oil removal filter to obtain maximum element service life.

SERVICING

1. Open manual drain to expel accumulated liquids. Keep liquids below element (51, 53).

2. Replace filter element when pressure drop across element exceeds 0,7 bar (10 psig). The mechanical service indicator shows approximately full red and the optional electrical service indicator provides an electrical output when pressure drop across element reaches 0,7 bar (10 psig).

DISASSEMBLY

1. Filter can be disassembled without removal from air line.

2. Shut off inlet pressure. Reduce pressure in inlet and outlet lines to zero.

3. Remove bowl - push into body and turn counterclockwise.

4. Disassemble in general accordance with the item numbers on exploded view. Do not remove the drains or the service indicators (1, 8) unless replacement is necessary. Remove and replace only if they malfunction.

CLEANING

1. Element (51, 53) cannot be cleaned. Clean plastic bowl (25, 42) and lens (3, 36, 47) with warm water only. Do not submerge electrical service indicator (8) in water. Clean indicator (8) with dry, clean cloth. Clean other parts with warm water and soap.

2. Rinse and dry parts. Blow out internal passages in body (6, 7) with clean, dry compressed air.

3. Inspect parts. Replace those found to be damaged. Replace plastic bowl with a metal bowl if plastic bowl shows signs of cracking or cloudiness.

ASSEMBLY

1. Lubricate o-rings, the portion of the manual drain body (18, 28) that contacts the bowl, and the hole in the manual drain body that accommodates the stem of drain valve (19, 29) with o-ring grease.

2. Assemble filter as shown on the exploded view.

3. Arrows on indicator (3, 10) and body (6, 7) must point in same direction. Push bowl, or bowl with guard, into body and turn fully clockwise.

4. Torque Table Torque in N-m (Inch-Pounds)

2, 9 (Screw) 2,8 to 3,9 (25 to 35)

22, 32 (Nut) 2,3 to 2,8 (20 to 25)

34, 45 (Screw) 1,7 to 2,3 (15 to 20)

51, 53 (Element) 0,5 to 2,2 (5 to 20)

CAUTION

Water and oil vapors will pass through these units and could condense into liquid form downstream as air temperature drops. Install an air dryer and an oil vapor removal filter if water and oil vapors could have a detrimental effect on the application.

WARNING

These products are intended for use in industrial compressed air systems only. Do not use these products where pressures and temperatures can exceed those listed under Technical Data.

Polycarbonate plastic bowls can be damaged and possibly burst if exposed to such substances as certain solvents, strong alkalies, compressor oils containing ester-based additives or synthetic oils. Fumes of these substances in contact with the polycarbonate bowl, externally or internally, can also result in damage. Clean with warm water only.

Use metal bowl in applications where a plastic bowl might be exposed to substances that are incompatible with polycarbonate.

Before using these products with fluids other than air, for nonindustrial applications, or for life-support systems consult Norgren.