

# Directional Spool Valves Type SW 1, SWR 1 and SWP 1

Directly solenoid-operated for oil-hydraulic systems

Operating pressure  $p_{\max} = 315$  bar, pump delivery rate  $Q_{\max} = 12$  l/min

Directional spool valve type SW 2 for  $p_{\max} = 315$  bar and  $Q_{\max} = 25$  l/min, see D 7451

## 1. General

Type SW 1 directional spool valves are used in oil hydraulic systems. Their purpose is to control the oil flow and thus the direction of movement of the consumer elements (hydraulic cylinders, hydraulic motors), or to act as pilot control devices. The range available includes single-action units for pipeline connection or baseplate mounting, and directional valve blocks for any desired arrangement in pipeline systems or for fitting onto hydraulic power units. Directional valve blocks consist of individual components, which are held together by powerful tension rods.

The valve part is made entirely of steel, and the housing is accordingly impervious to pressure shocks. Leaks are eliminated from the outset with this design, unlike cast iron housings on which leaks are sometimes observed after considerable periods of operation, occurring in the form of hairline cracks which move outwards, especially if such units are being used at maximum permissible pressure ranges. The boreholes in the housings are diamond-honed, and the hardened and ground valve pistons are polish-deburred. This maintains true roundness and precise geometrical shape (no wear or widening of control edges), and provides a uniform sealing gap with minimum leakage rate.

Actuation takes place by means of single-stroke solenoids (wet-armature solenoids) flanged onto the housing opposite one another, which take immediate effect on the valve piston. The zero setting is assumed automatically by means of spring centering, and a 4/2-way design is available with catches in the two switching positions.

## 2. General View

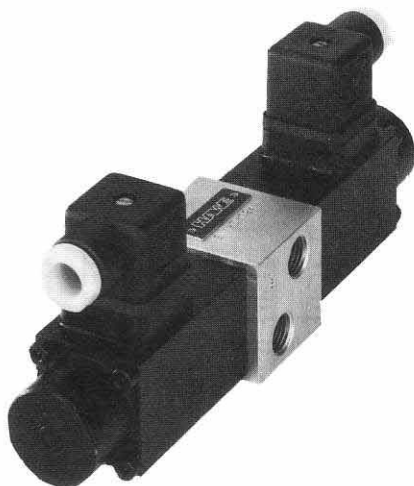

Single valves  
Page 2 ff

- SW 1 for direct pipe connection, standard design (photo)
- SWR 1 for series connection for flanging together laterally to form directional valve blocks, or for mounting on connection plates provided by client
- SWP 1 for plate mounting for fitting to base blocks prepared by client, or equipped at manufacturer's works with connection plates with/without pressure limiting valve

Directional valve block  
Page 6 ff

- for direct connection to the pipeline system  
Standard design consisting of series valves flanged laterally onto each other (photo);  
in the case of valves mounted on plates, the baseplates themselves are flanged laterally to each other.
- for mounting on hydraulic power units in standard design, not so usual as plate mounting

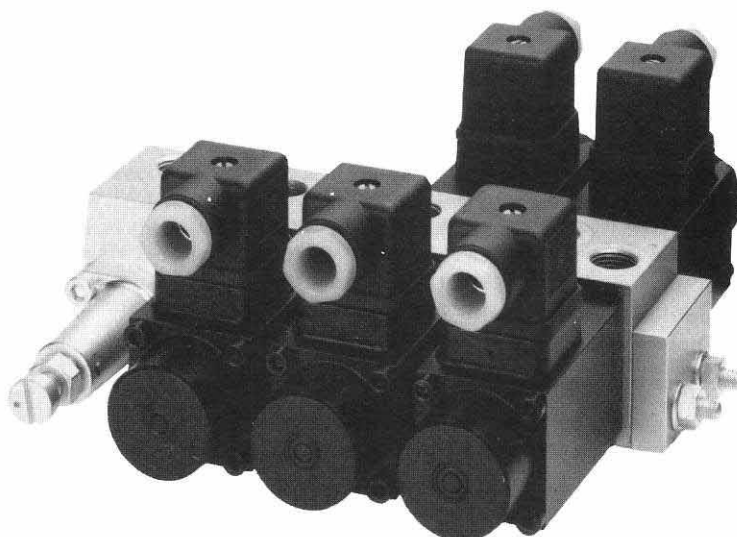

3. Types Available, Type Code, Main Data  
 3.1. Single valves

Example 1:  
 Single valves for pipeline connection (standard design), flow diagram G, for 24 V =

Example 2:  
 Single valves for plate mounting, flow diagram L, connection plate with pressure limiting valve, 150 bar, for 220 V~

**SW 1 G - G 24**  
**SWP 1 L - 1/4 S - WG 220 - 150**

For all other general, hydraul. and electrical characteristic data, see Sect. 4, page 5

desired pressure setting (bar) only with designs -1/4 S and -1/4 SR (Table 4)

= DC  
 ~ AC

Table 4

Table 3

Table 1 Basic type designation			
Basic type	Connection mode	Connection size	Main hydr. data
<b>SW 1</b>	Pipeline connection	G 1/4 DIN ISO 228/1	Press. $p_{max}$ = 315 bar
<b>SWR 1</b>	Series mounting <sup>1)</sup>	Hole pattern, see Section 3.3	Pump delivery rate $Q_{max}$ = 12 l/min
<b>SWP 1</b>	Plate mounting		

Table 3 Rated voltage $U_N$			
DC voltage		AC voltage	
Coding	$U_{nomin}$	Coding	$U_{mains}$
<b>G 12</b>	12 V =	<b>WG 220</b>	220 V~ 50 and 60 Hz
<b>G 24</b>	24 V =	<b>WG 110</b>	110 V~

Preferential voltages for further voltages see Section 3.2.2

Table 4 Connection block for single valves SWP 1 (optional)		
Coding	Pressure limiting valve	Connection size
<b>-1/4</b>	without	G 1/4 DIN ISO 228/1
<b>-1/4 S</b>	fixed setting	
<b>-1/4 SR</b>	adjustable	

- 1) as a single valve for lateral flanging to a connection block provided by client (with end plate as per Section 4); series valve for standard directional valve block SWR 1... as per Sect. 4.1
- 2) for use as a 4/2-way directional valve with only one actuation solenoid for switch settings 0 and a or 0 and b only after previous enquiry, since this requires a special spring-loaded sleeve in a special design
- 3) electrical actuation with detent by power pulse of approximately 0,5s
- 4) only as bypass valve in directional valve blocks SWR 1... and SWP 1... in Section 4
- 5) only available for series fitting SWR 1...
- 6) identical to G valves, but connection B closed off inside the housing with a screw plug
- 7) identical to W valves, but connection B closed off inside the housing with a screw plug
- 8) only available for plate mounting SWP 1...

Table 2 Flow diagrams													
Switch position	Use Code letters and symbols												
4/3- and 3/3-way valves <sup>2)</sup>	<table border="1"> <tr> <th>G</th> <th>D</th> <th>E</th> <th>O</th> <th>C<sup>5)</sup></th> <th>N<sup>6)</sup></th> </tr> <tr> <td></td> <td></td> <td></td> <td></td> <td></td> <td></td> </tr> </table> <p>suitable for parallel connection and usage for bank mounting acc. to Sect. 4</p>	G	D	E	O	C <sup>5)</sup>	N <sup>6)</sup>						
G	D	E	O	C <sup>5)</sup>	N <sup>6)</sup>								
4/2-, 3/2- and 2/2-way valves	<table border="1"> <tr> <th>B</th> <th>W</th> <th>K<sup>3)</sup></th> <th>Q</th> <th>R<sup>7)</sup></th> <th>U<sup>4)</sup></th> </tr> <tr> <td></td> <td></td> <td></td> <td></td> <td></td> <td></td> </tr> </table> <p>suitable for series connection unsuitable for bank mounting acc. to Sect. 4</p>	B	W	K <sup>3)</sup>	Q	R <sup>7)</sup>	U <sup>4)</sup>						
B	W	K <sup>3)</sup>	Q	R <sup>7)</sup>	U <sup>4)</sup>								
	<table border="1"> <tr> <th>L</th> <th>F</th> <th>H</th> <th>S</th> <th>Y<sup>8)</sup></th> </tr> <tr> <td></td> <td></td> <td></td> <td></td> <td></td> </tr> </table> <p>Blank plate (only on Type SWP1) <b>X</b> instead of a valve (to be provided later) on the already existing base plate</p>	L	F	H	S	Y <sup>8)</sup>							
L	F	H	S	Y <sup>8)</sup>									

Symbols

Type SW 1: identical with layout shown above, Table 2

Type SWR 1:

Type SWP 1:

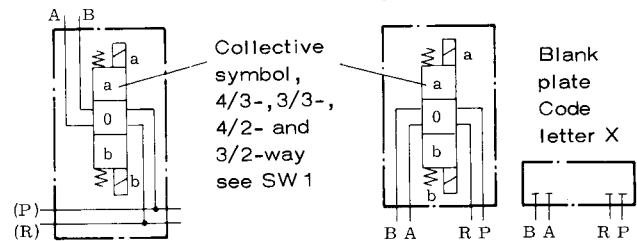

Type SWP 1...-1/4

...1/4S

...1/4SR

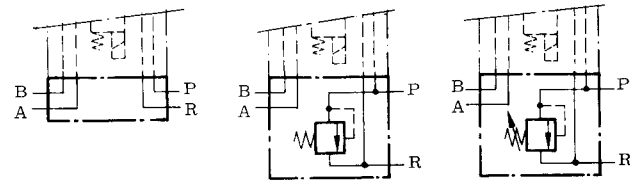

3.2. Characteristic Data

3.2.1. General

Type designation as per type code Section 3.1

Design Piston-longitudinal spool valve

Mounting Threaded holes M6, 8 deep; see dimensional sketches

Line connection Pipe thread G 1/4 (exception: R = G 3/8 with SWR 1F) as per ISO 228/1, suitable for pipe screw connections with screw males shape B to DIN 3852

P = Pump connection R = Return connection, pressure-loadable up to  $p_{max}$ ; not pressure-loadable (max. 12 bar)

A, B = Consumer connection in design with pressure limiting valve

M = Pressure gauge connection in design with pressure limiting valve

In the case of -1/4S(R), the components of the pressure limiting valve MVB 4 are fitted as standard in accordance with D 7000E/1 (spring dome made of diecast zinc). In the event of pressure surges in the return line (> approx. 20 bar), e.g. as a result of decompression surges of accumulator-capable consumers, it is also possible to use components of the MVB 4 with a steel spring dome. Please state in clear text when ordering, e.g. SW 1E - 1/4S - G 24 - 200 with steel spring dome

Flow direction see flow diagrams, Section 3.1

Installed position as desired

Mass (weight) SW 1, SWR 1 and SWP 1 G, D, E, O, C, N, K, L, H, S, Y ..... 1,65 kg  
 SW 1, SWR 1 and SWP 1 B, Q, R, W, U ..... 1,1 kg  
 Connecting plate SWP 1 .. - 1/4 ..... 0,6 kg  
 Connecting plate SWP 1 .. - 1/4 S and 1/4 SR ..... 0,7 kg

Ambient temperature - 40 ... + 80°C, at less than > 40°C, observe duty cycle, see Sect. 3.2.2

Pump delivery rate  $Q_{max}$  12 l/min (greatest permissible reflux flow approx. 24 l/min)

Pressure  $p_{max}$  315 bar

Pressure medium Hydraulic oil in accordance with DIN 51 524, Parts 1 and 2  
 ISO VG 10 to 68 in accordance with DIN 51 519  
 Viscosity limits min. 4 mm<sup>2</sup>/s; max. approx. 1500 mm<sup>2</sup>/s  
 Viscosity range for optimum operation approx. 10 ... 500 mm<sup>2</sup>/s  
 A greater increase in the flow resistance can be expected for viscos. over 500 mm<sup>2</sup>/s.  
 Please enquire for other media.

Overlapping zero

Δp - Q characteristic curves

Oil viscosity during measurement 60 mm<sup>2</sup>/s

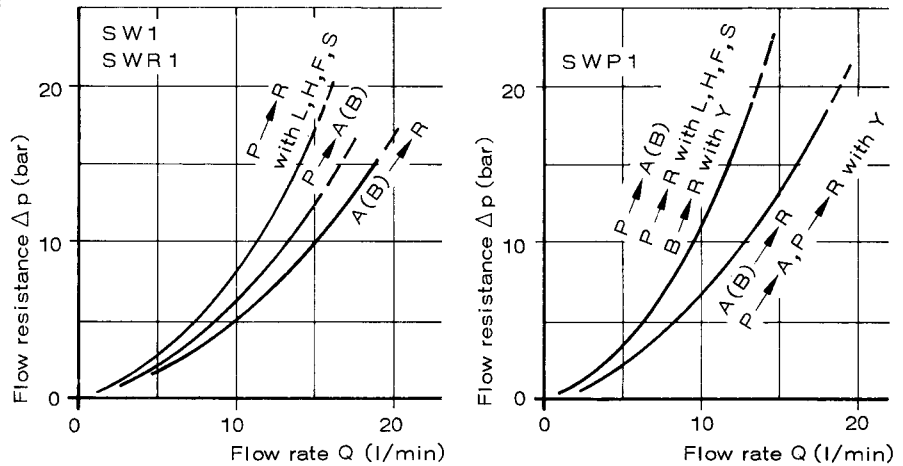

The characteristic curves apply in each case to a flow direction P → R (bypass), P → A(B) or A(B) → R. With 4/3 or 4/2-way directional valves, the total resistance value  $\Delta p_{total}$ , measured at the input P, is made up of the inlet side fraction  $\Delta p_{inlet}$  and the outlet side fraction  $\Delta p_{outlet}$ . A point to be noted here is that if the consuming elements have unequal surface ratios (differential cylinders), then the return flow  $Q_{return}$  (to be read off via the  $\Delta p_{outlet}$ ) may be smaller or larger than the inlet  $Q_{inlet}$  (for  $\Delta p_{inlet}$ ), depending on the direction of movement.

$$\Delta p_{total} = \Delta p_{inlet} + \Delta p_{outlet} \frac{A_{outlet}}{A_{inlet}}$$

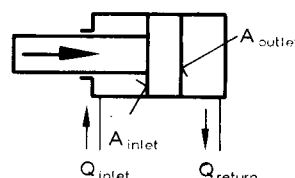
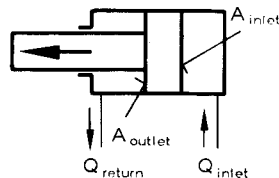

$$Q_{return} = Q_{inlet} \frac{A_{outlet}}{A_{inlet}}$$

## 3.2.2. Electrical

Solenoid	Constructed and tested in accordance with VDE 0580, switches pressure-tight in oil Recommended value for rated power $P_N \approx 24,4 W \pm \text{appr.} 6\%$ , dep on rated volt. $U_N$ and make														
Coding in acc. Sect. 3.1	G 12	G 24	G 36	G 42	G 48	G 60	G 72	G 80	G 98	G 110	G 180	G 196	WG 110	WG 220	
Rated voltage $U_N$ V	12	24	36	42	48	60	72	80	98 <sup>1)</sup>	110	180	196 <sup>1)</sup>	110	220	
	Direct voltage DC												Alternating volt. AC 50 and 60 Hz		
Recomm. val. curr. $I_{20}$ A	2	1	0,64	0,56	0,54	0,4	0,35	0,33	0,25	0,22	0,15	0,14	0,25	0,14	
Time constant $\tau$	Start of stroke appr. 9,3 ms End of stroke appr. 25 ms						Inductance $L = 1000 \tau \cdot R$ (H)						(Recommended value for R in $\Omega$ from $R = U_N / I_{20}$ )		
Diagrams (apply to solenoid a and b)	Direct voltage G... 						Alternating voltage WG... 								
Appliance plug	A DIN 43 650 Coding G (...V DC) is supplied with gray and black plug Coding WG (...V AC) is only supplied with black plugs with bridge rectifier insert (Make: Klar u. Beilschmidt, 8300 Landshut)												Gray plug	Black plug	
Relative duty cycle	100% duty cycle Stamp on the magnet			In operation:			at ambient temperature ( $^{\circ}\text{C}$ )			< 40		60		80	
				duty cycle (%)					100		appr. 60		appr. 40		
Swit. times (rec. values)	On: approx. 60...70 ms						Off: approx. 30...60 ms								
Switching frequency	approx. 3600 switching operations/hour														
Prot. class DIN 40 050	Solenoid IP 65, connection IP 65 (appliance socket fitted)														
Insulat. material class	F														
Contact temperature	approx. 85 $^{\circ}\text{C}$ at 20 $^{\circ}\text{C}$ ambient temperature														
Mountability	After undoing four retaining screws, the magnet can simply be pulled off axially and replaced by a new one in the event of an electrical defect														

<sup>1)</sup> For connecting to alternating voltage 50/60 Hz via separately arranged, customer-furnished bridge rectifier (silicon rectifier): G 98 for mains 110 V AC; G 196 for mains 220 V AC

## 3.3. Dimensions of Units All dimensions are in mm, Subject to change without notice !

Type SW1

4/3-way and 3/3-way directional spool valves

Code letter G, D, E, O, C, N, L, F, H, S and K

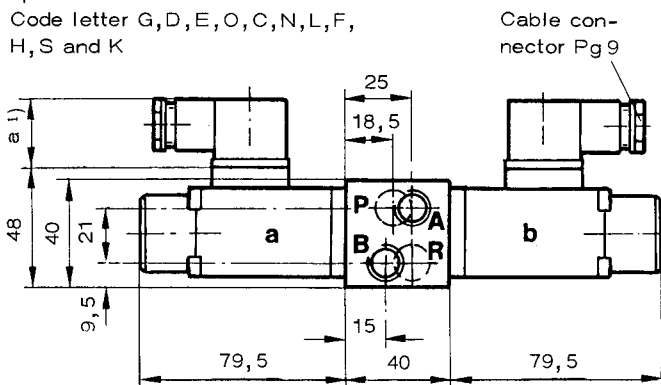
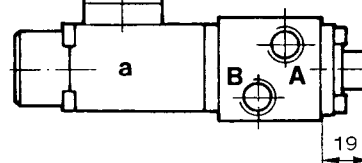
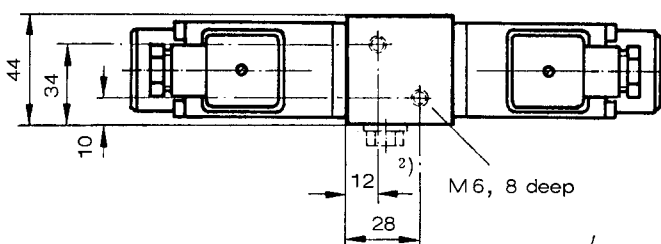
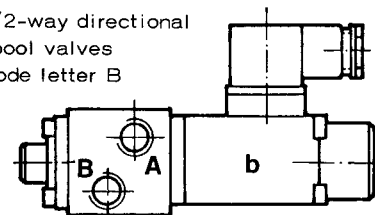
4/2-way directional spool valves  
Code letter Q, R, W4/2-way directional spool valves  
Code letter B

Manual emergency operation

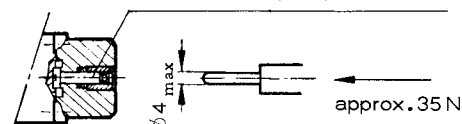

Connections A, B, P, R = G 1/4

**Type SWR 1**

3/3-way and 4/3-way directional spool valves Code letter G,D,E, O,C,N,L,F,H,S and K

Cable connector Pg 9

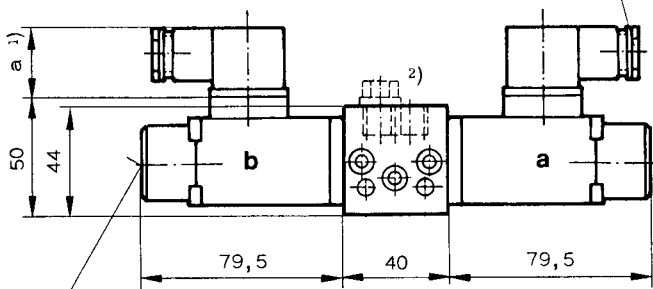

Manual emergency operation see SW 1 !

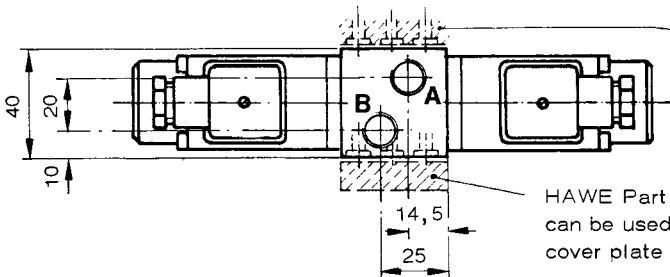

HAWE Part 7450 006 can be used as a cover plate

Hole pattern for customer-furnished connection block:

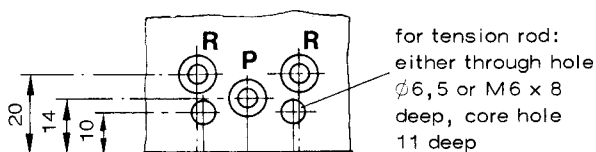

O-ring 6,07 x 1,78

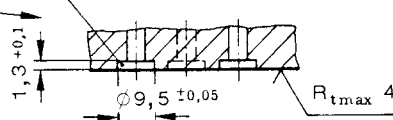

R\_tmax 4

Ø6,5 continuous for tension rod

4/2-way directional spool valves Code letter Q,R,W

Code letter B

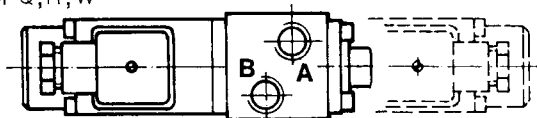

**Type SWP 1** 3/3-way and 4/3-way direct.spool valves Code lett.G,D,E,O,C,N,L,F,H,S and K

**Type SWP 1...-1/4**  
**SWP 1...-1/4S (SR)**

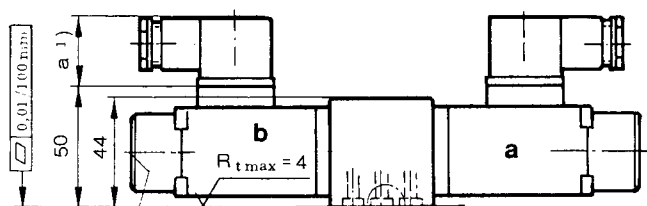

Manual emergency operated see SW 1 !

Hole pattern of the base plate (top view)

M5, 5 deep

Cable connector Pg 9

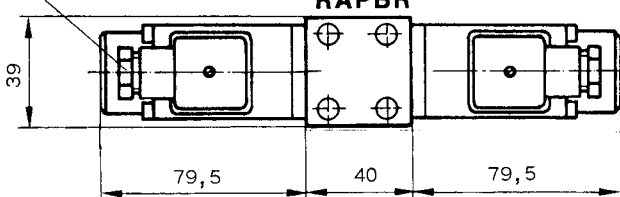

Centering pin, hole Ø3 2,5 deep

Connections A,B,P,R sealed by O-ring 5 x 1,5; P connection sealed by O-ring 6 x 1,5 in the case of SWP 1...9

**RAPBR**

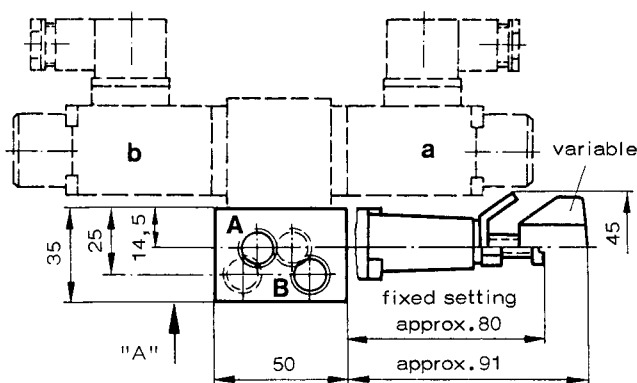

View A:

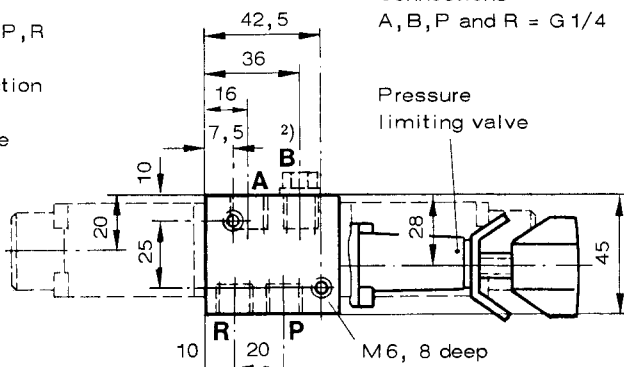

Connections A,B,P and R = G 1/4

Pressure limiting valve

4/2-way directional spool valves Q...B like above SWR 1

1) a = 29 (G12 to G 196); 34 (WG 110 and WG 220)  
These dimensions are determined by manufacturer (in this case, Messrs. Klar & Beilschmidt, Landshut), acc. to DIN 43 650, up to max. 40 mm is possible !

2) for valves N and R, connection B is closed; (Screw plug G 1/4 DIN 910, modified to sealing edge, HAWE No. 2749 003)

4. Directional valve blocks

4.1. Type code, main data

Example 1:

Directional valve block, rowed-up design, flow diagrams U (circulation), G and D, 24V DC magnet and pressure limiting valve 120 bar

Example 2:

Directional valve block in rowed-up design for mounting on hydraulic power units type MP (D 7200), HC (D 6900) and HK (D 7600, D 7600-24 and D 7600-34)

**SWR 1 A 6 - UGD - 1 - G 24 - 120**

**SWR 1 F - GDE - 1 - WG 220**

Desired pressure setting (bar)

Possible press. ranges:  
 (0) ... 80 bar  
 (0) ... 160 bar  
 (0) ... 315 bar  
 Press. specification determines spring.

Given only for version with press. limit. valve

Mode of operation  
**G 12 to W 220**  
 as per Sect. 3.1 & 3.2.2

Table 1	Basic type and size
<b>SWR 1</b>	Rowed-up design, series
	Plate design This version is more expensive. Line connections possibly only accessible with directional spool valves removed after securing to a mounting wall.
<b>SWP 1</b>	Good disassembly possibility without disconnecting the pipelines.

Table 2	Connection blocks, adapter plates			
in comb. with	Design Code	Description		
SWR 1 and SWP 1	<b>A 5</b>	Without pressure limiting valve	for pipr mounting	
	<b>A 6</b>	Pressure limiting valve fixed setting		Serie: Spring dome made of diecast zinc
	<b>A 7</b>	Pressure limiting valve adjustable		Spring dome made of steel <sup>1)</sup>
	<b>A 3</b>	Pressure limiting valve fixed setting		
	<b>A 4</b>	Pressure limiting valve adjustable		
	<b>F</b>	For fitting on hydraulic power units HC (D 6900), MP (D 7200), HK (D 7600...)		
Only SWP 1	<b>FP</b>	For FP pump (D 7310)		
	<b>B 4</b>	100...315	Same as type F/FP, but with press. switch unit DG 34(35) in acc. with D 5440, for fitting to HC (D 6900), MP (D 7200) and HK (D 7600...)	
	<b>B 5</b>	20...210		
Only SWR 1	<b>D</b>	For fitting to R hydraulic power units, tank size B 50, D 50 and B 75 in accord. with D 6010. Fitting to smaller tanks (B 6...B 40) not possible due to space required for motor.		
	<b>SE...FA...</b>	For pipeline install., with press. limiting valve fixed setting and electrically proportional flow control, see Appendix Sect. 5.1		

Table 3	End plates
<b>1</b>	SWR 1 SWP 1

See Sect. 3.1 for flow diagrams  
 The sequence of code letters corresponds to the sequence of valves starting from the connection block.  
 Max. 10 fitted parts (valves or auxiliary elements, Sect. 4.2), also see Dimens. sketches in Sect. 4.4

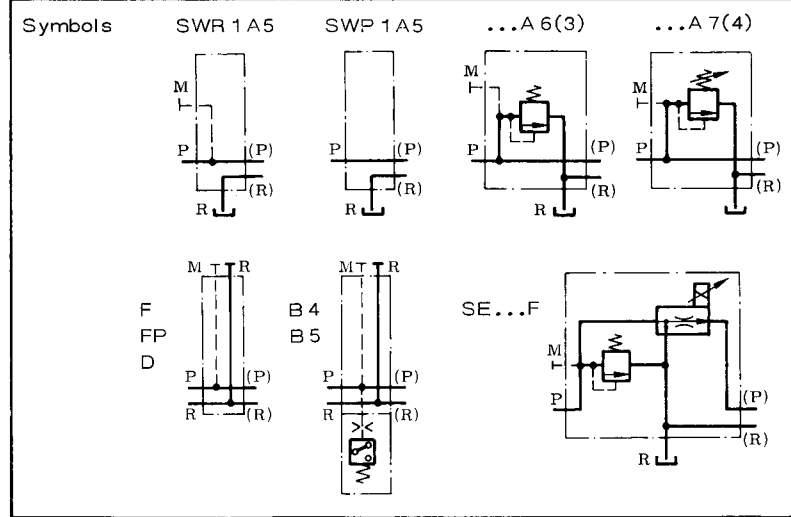
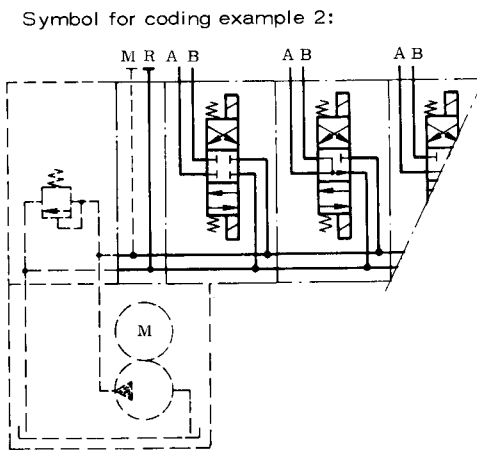
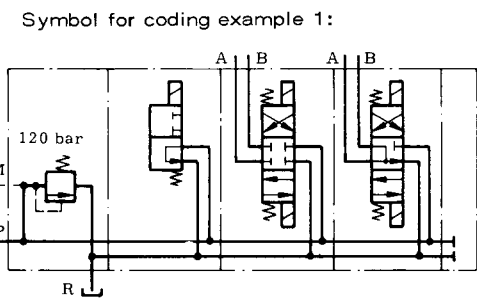

1) Only in the event of pressure surges (> 20 bar) in the return line, e.g. as a result of decompression surges of accumulator-capable consumers (large volume, very long pipelines, etc.)

4.2. Supplementary Devices for Directional Valve Blocks as per Section 4.1.

4.2.1. Pressure control valve (pressure reducing valve)

For use in hydraulic circuits if a higher operational pressure (primary pressure) is not required or is not permissible from the inflow supply network for the consumer elements connected to the directional valve block, due, for example, to functional or manufacturing design reasons. Example: Directional spool valves are used as pilot valves for electrohydraulic remote actuation (flow diagram D).

Pressure control valves can be integrated in the connection block (only with SWR 1), or incorporated at any desired point between the directional spool valves. The directional valve section, which follows the pressure control valve if seen looking from the connection block, only receives pressurized oil at reduced (secondary) pressure.

SWR1 **Z3** -DD-1-G 24

Coding example 1:

Series version SWR 1 with pressure control valve in connection block, i.e. at the first location in the valve series, Z.. stands in place of designation A 5 (A 6) in Section 4.1 in this case

SWR1 A6 - GE **Z7** D - 1-G 24 - 250

Coding example 2:

Series version SWR 1 with the pressure control valve at any point in the valve series

SWP 1 A5- **Z2** GE - 1 - WG 220

Coding example 3:

Press. control valve at first locat. in the valve series in the case of SWP 1...

SWP 1 F-G **Z5** D - 1 - G 24

Coding example 4:

Press. control valve at any point in the valve series in the case of SWP 1...

<b>Z1</b>		<b>Z5</b>	160 ... 250 bar	Adjustable pressure range <sup>1)</sup> (secondary pressure)  $P_{S \min} \dots P_{S \max}$	<p><math>P_{A(B)} - Q_{A(B)}</math> - Characteristic curve</p> <p><math>\approx -10 \dots -15\%</math> of preset pressure, depending on pressure range</p>
<b>Z2</b> Fixed setting	<b>Z6</b> Adjust. by hand	60 ... 160 bar			
<b>Z3</b>	<b>Z7</b>	30 ... 130 bar			
<b>Z4</b>	<b>Z8</b>	10 ... 30 bar			

<sup>1)</sup> Pressure set with the pressure gauge in the case of  $Q_{A(B)} = 0$  l/min (consumer in end setting). The pressure drops somewhat when pressurized oil flows to the consumer. Pressure range 10...30 bar (Z 4 and Z 8) for small consumer currents only (pay attention to flow resistance of the downstream valves).

As an individual unit for replacement, own stocks, etc., the order code for positioning at any desired location is: ADS - Z 1 (up to Z 8) in the case of SWR 1..., ADM 11 P... in the case of SWP 1..., in accordance with D 7120

Z valves are preset at the manufacturers' works to the particular maximum pressure in each case if no pressure data are provided in the order. If a specific pressure setting is required, then it should be entered in clear text after the order designation; the valves will then be sealed at the works.

The permissible pressure in the return (R channel) is approximately 12 bar. The Z valve can only also be fitted with a steel spring dome if desired if there are pressure surges (> 20 bar) in the return line, e.g. as the result of decompression surges (high volumes, very long pipelines, etc.). This must be stated in clear text at the end of order code.

Coding example 1:

Coding example 2:

Coding example 3:

Coding example 4:

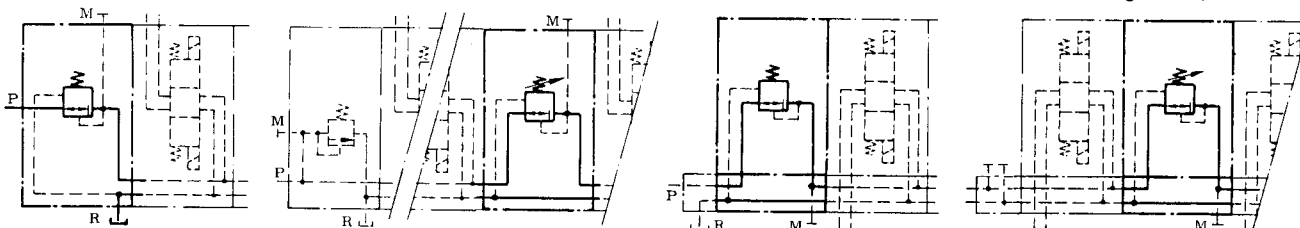

4.2.2. Check valves for SWP 1... See Section 4.3.1 for additional characteristic data

SWP 1 A 6 - UG **1 D 2 D 9** - 1 - G 24

Designation same as in Section 4.1

<b>1</b>	Pilot-operated check valve for A	not for flow diagrams C, N, R, U
<b>2</b>	Pilot-operated check valve for A and B	
<b>9<sup>2)</sup></b>	Check valve insert in accordance ER 01 with D 7325 in P	

<sup>2)</sup> Important: delivery flow in accordance with D 7325 restricted to approx. 6 l/min. Not retrofittable, must be stated when ordering.

Symbol

Code number 1  
Example **G1**

Code number 2  
Example **D2**

Code number 9  
Example **D9**

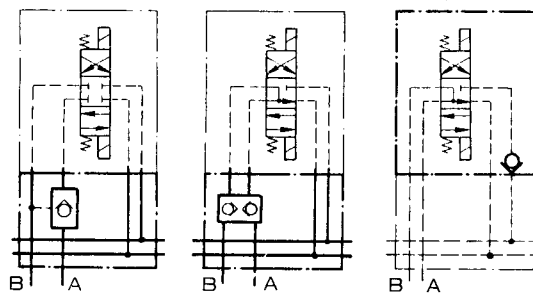

4.3. Characteristic data

Only insofar as not shown in Section 3.2.1 and 3.2.2 or in the event of deviation from these sections.

4.3.1. General and hydraulic

Type code as per type code, Section 4.1

Mounting through holes  $\phi 6,3$  or tapped mounting holes M6 x 8 deep, depending on design, see dimensional sketches

Mass (weight)	Connection blocks	appr.kg	Directional spool valves	appr.kg
	SWR 1A 5 .....	0,5	SWR 1G,D,E,O,C,N,K ..	1,65
	SWR 1A 1,2,3,4,6,7 ..	0,6	SWR 1B,Q,R,W,U .....	1,1
	SWR 1F .....	0,6	SWR 1Z 1 to Z 8 .....	0,7
	SWR 1D .....	0,55		
	SWR 1SE.. .....	1,1		
	SWR 1Z... .....	0,7		
	SWP 1A 5 .....	0,2	SWP 1G,D,E,O,C,N,K ..	1,95
	SWP 1A 1,2,3,4,6,7..	0,6	SWP 1B,Q,R,W,U .....	1,4
	SWP 1F and FP .....	0,6	SWP 1X .....	0,5
	SWP 1B 4, B5 .....	0,9	SWP 1Z 1 to Z 8 .....	0,9

End plates for all versions .... 0,1 kg

$\Delta p$  - Q characteristics

Directional spool valves:

The characteristic apply to five directional spool valves. The actual resist. depends on the number of valves and on the number of the example in question. More precise calculat. wastes time and results in only rough approximate values, meaning that the time spent is normally not worthwhile and an estimate on the basis of the tables below is sufficient in most cases.

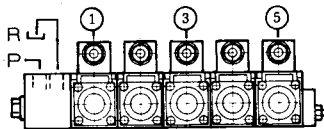
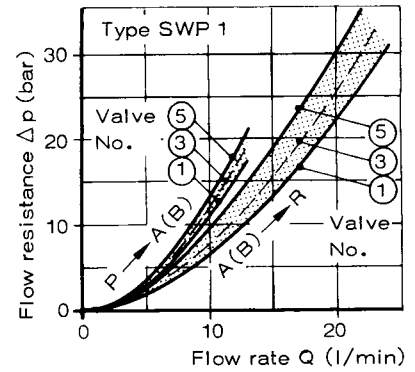
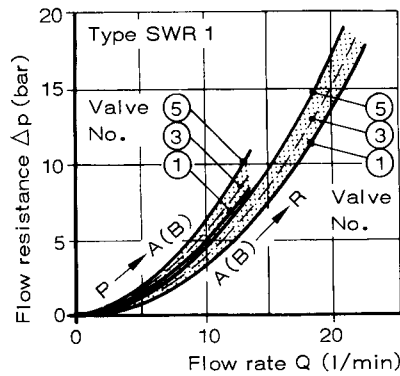

When determining the flow resistance, pay attention to the area ratio of the connected consumers (differential cyl.), see Section 3.2.1!

Check valves in accordance with Section 4.2.2:

Check valve  
Code number 9

Pilot-operated check valves, code numbers 1 and 2

$\Delta p$  - Q - characteristic

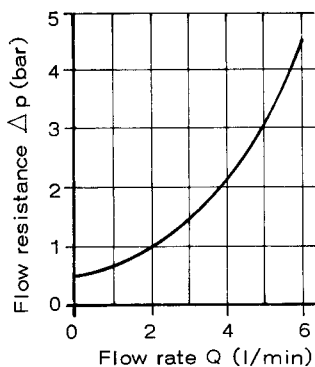

$\Delta p$  - Q - characteristic

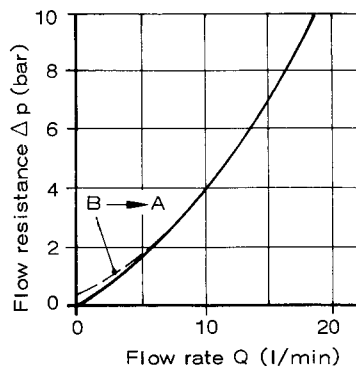

Control pressure

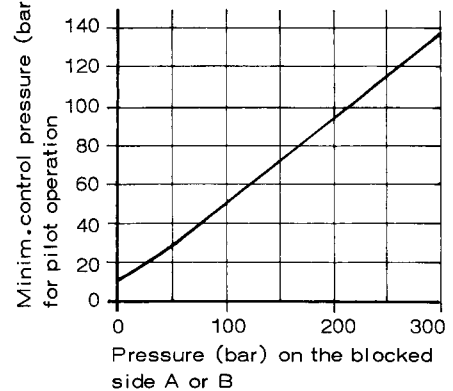

The  $\Delta p$  read off must be added to the above  $\Delta p$  of the SWP 1 valve.

Minimum pressure for keeping open:

$$p_{St} \approx \Delta p_{ab} + 0,45 \Delta p_v$$

$\Delta p_{ab}$  = outlet - side valve resistance from above  $\Delta p$ -Q-characteristics

$\Delta p_v$  = resistance of the stop valve itself

Oil viscosity during the measurement appr.  $60 \text{ mm}^2/\text{s}$



4.4. Dimensions of Units All dimensions are in mm. Subject to change without notice!

4.4.1. Rowed-up design SWR1...

Type SWR1

Manu. emergency operation (see Sect.3.3)

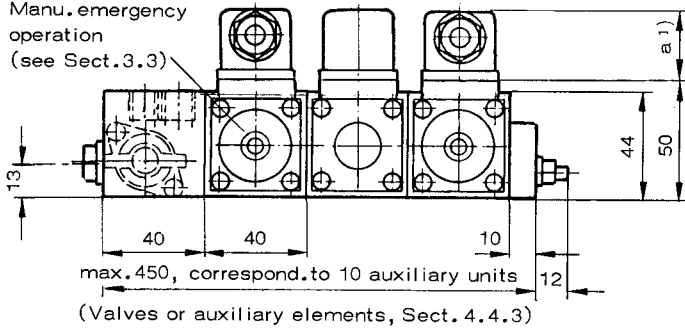

Type SWR1F-....

Connection block on the pump

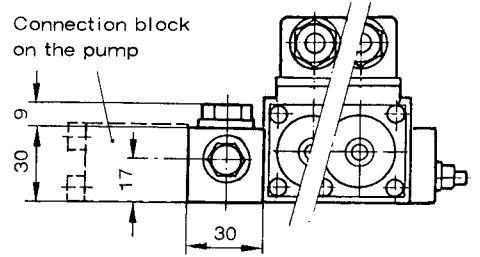

refer to SWR 1A-.... for details not given

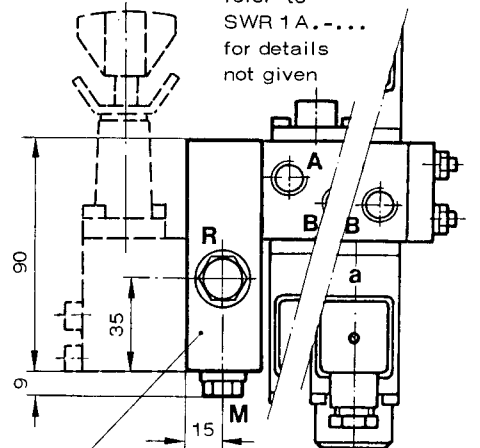

Adapter plate with return connection R = G3/8 press.gauge connection M = G1/4

1) a = 29 in the case of solenoid G 12 to G 196 34 in the case of solen. WG 110 & WG 220

These dims. are determined by manufacturer (in this case, Messrs. Klar & Beilschmidt, Landshut), acc. to DIN 43 650, up to max. 40 mm is possible

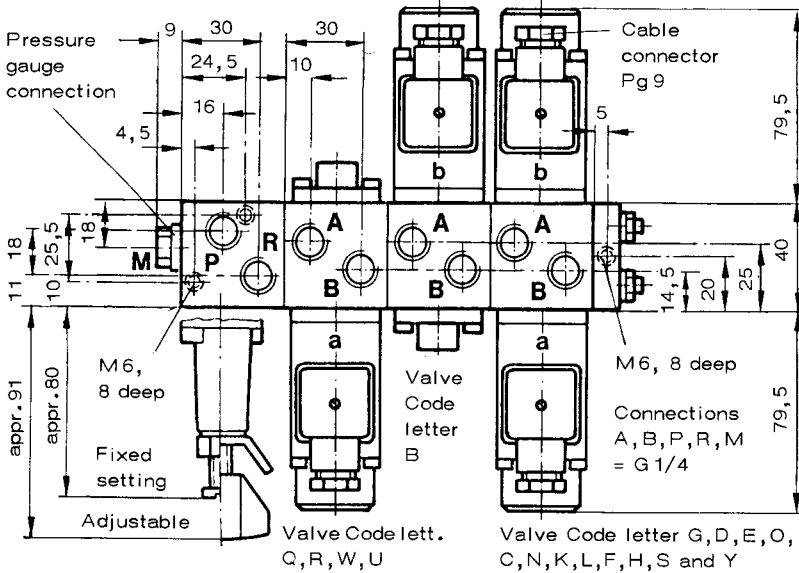

Important note: For valves N and R, connection B, for valves U, connect. A and B are closed (closure screw plug as in Sect. 3.3)

Type SWR1D-....

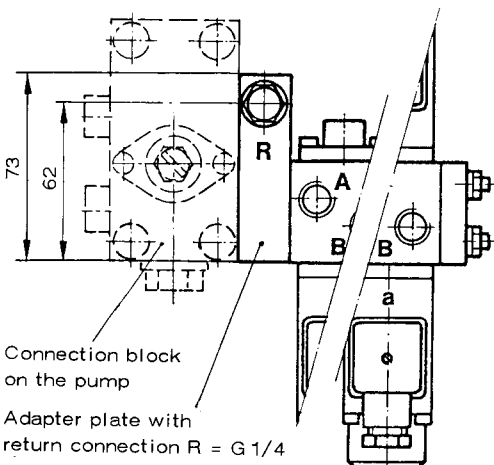
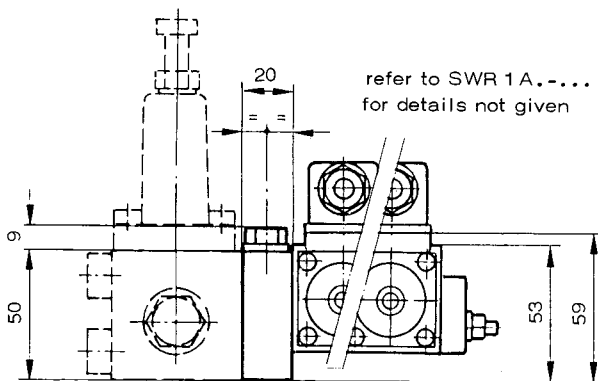

Type SWR1SE...FA... (see Sect.5.1)

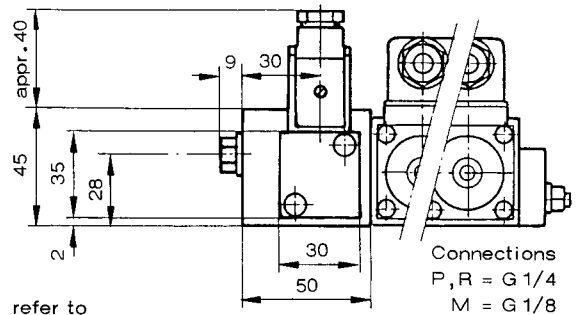

refer to SWR 1A-.... for details not given

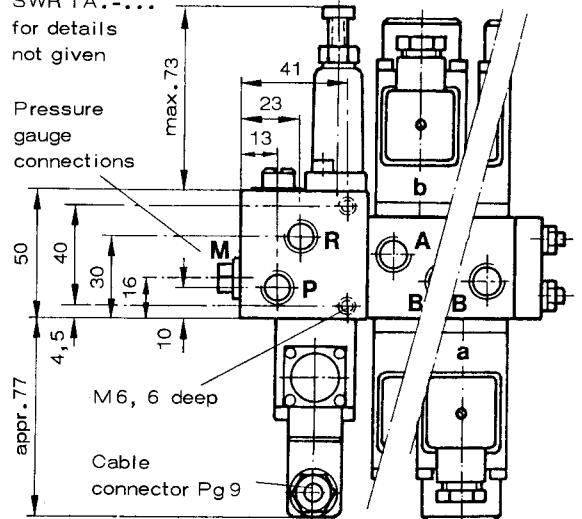

4.4.2. Plate design SWP1..

Type SWP1A.....

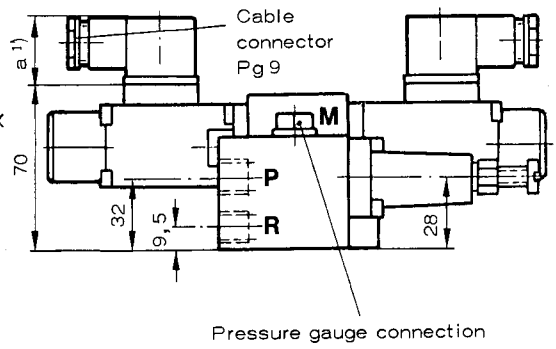
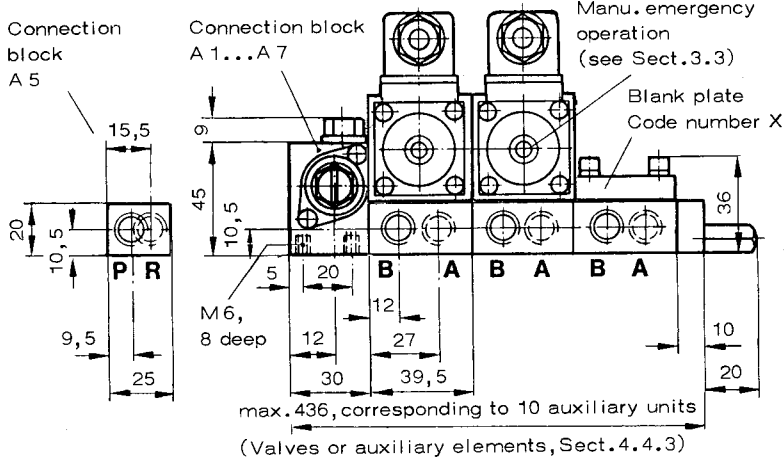

Connections  
A, B, P, R and M = G 1/4

Important note:  
Solenoid "a" not provided with valve B, solenoid "b" not provided with valves Q, R, W and U (as for Type SWR 1A..., Sect. 3.3)

With valves N and R, connection B is enclosed in the base plate, and connections A and B with valve U (screw plug G 1/4 DIN 910, modified on sealing edge, HAWE number 2749 003)

1) a = 29 with solenoid G 12 to G 196  
34 with solenoid WG 110 and WG 220  
These dimensions are determined by manufacturer (in this case, Messrs. Klar & Beilschmidt, Landshut); according to DIN 43 650, up to max. 40 mm is possible

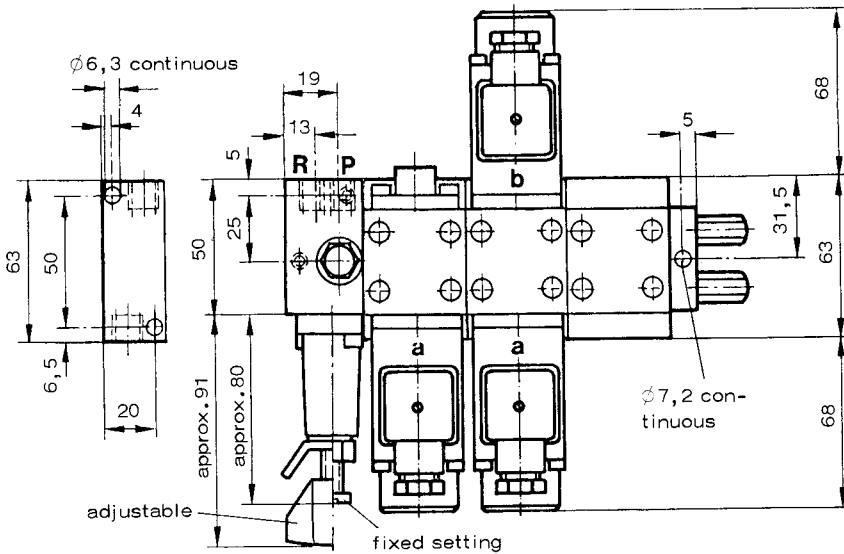

Type SWP1F

Connection block on the pump

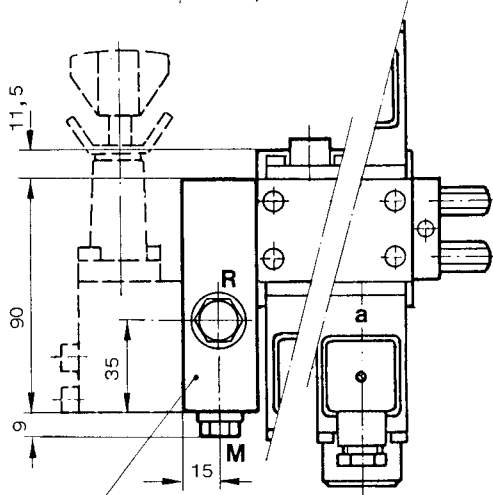
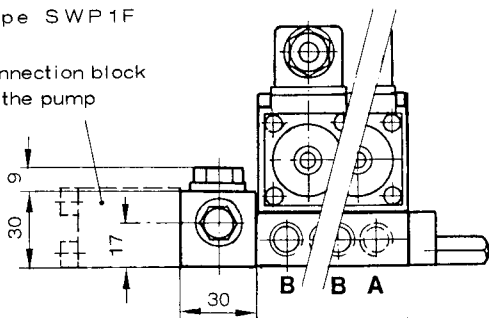

Adapter plate with  
return connection R = G 3/8  
pressure gauge connection M = G 1/4

refer to SWP 1A.....  
for details not given

Type SWP1FP

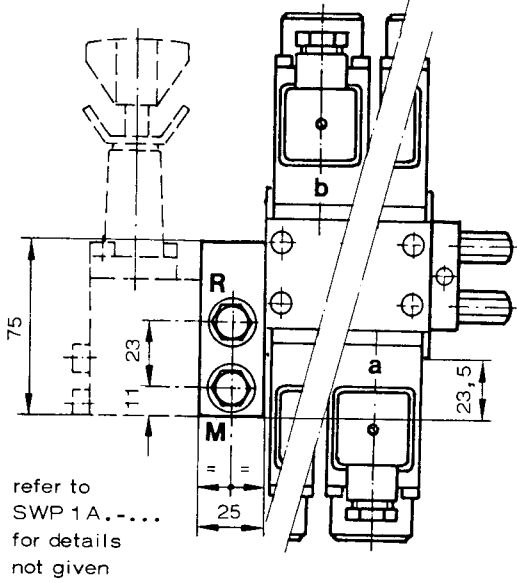
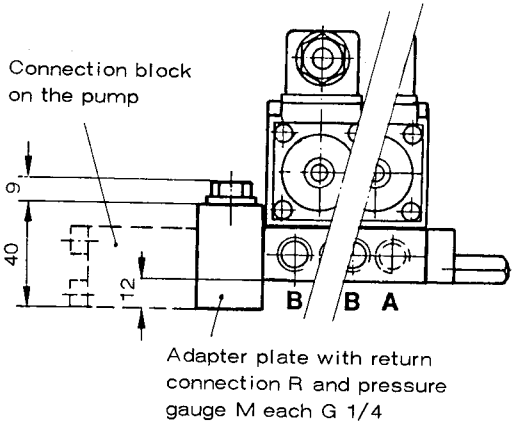

Type SWP1 B4 and SWP1 B5

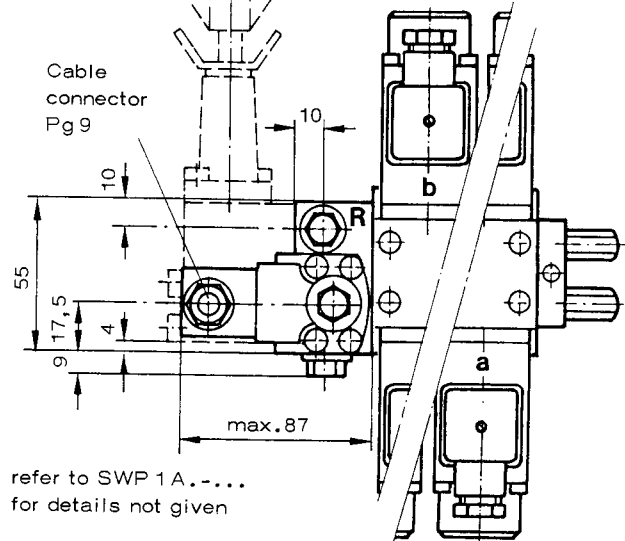
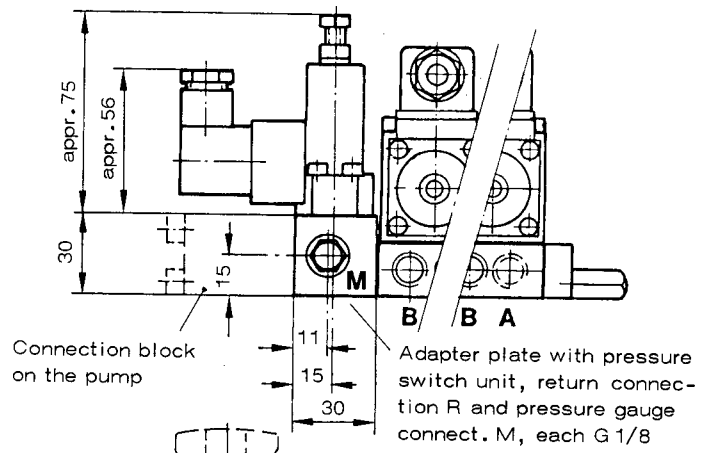

4.4.3. Auxiliary elements as per Section 4.2.2

G1 (D1,E1...etc.), G2 (D2,E2...etc.), G9 (D9,E9... etc.) Check valve

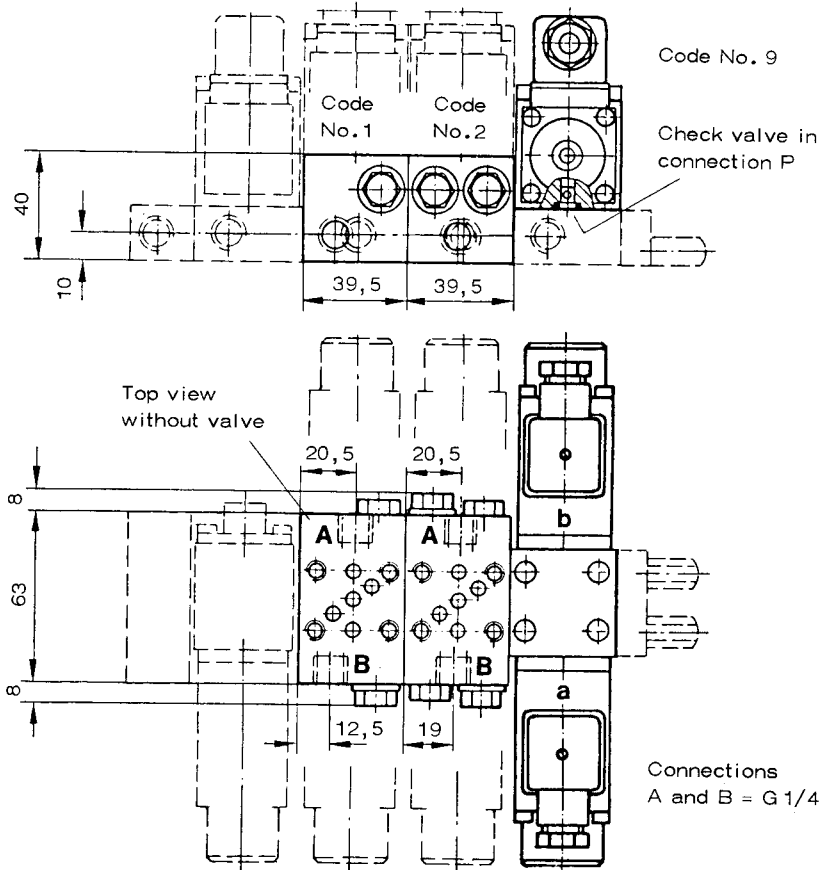

4.4.4. Pressure control valve for SWR 1... and SWP 1...

Pressure control valve as first function element (all directional spool valves on the secondary side)

Type SWR 1 Z...

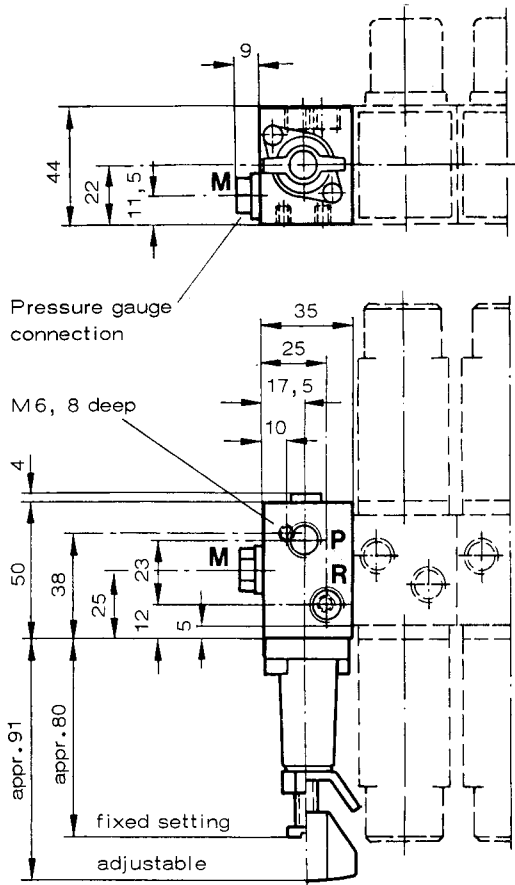

Connections P, R and M = G 1/4

Pressure control valve on any desired side in directional valve block

Type SWR 1...Z

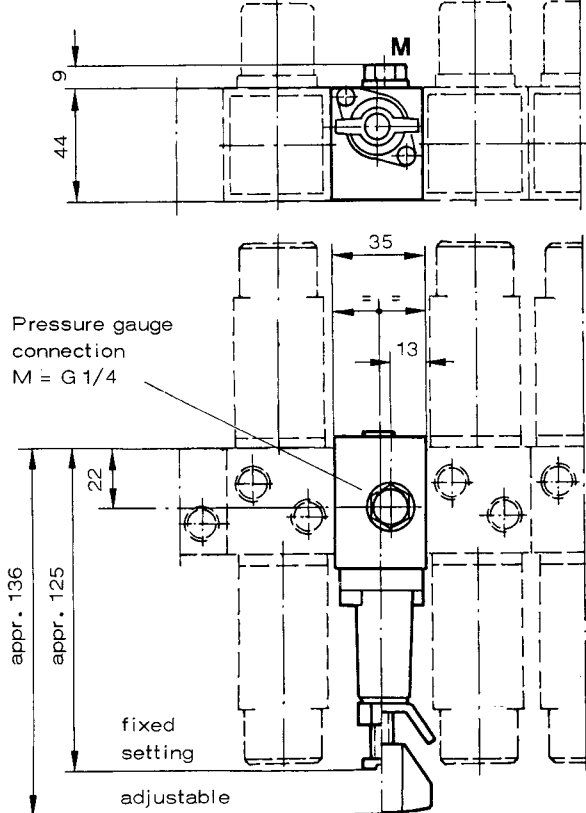

Type SWP 1 A 5 - Z...

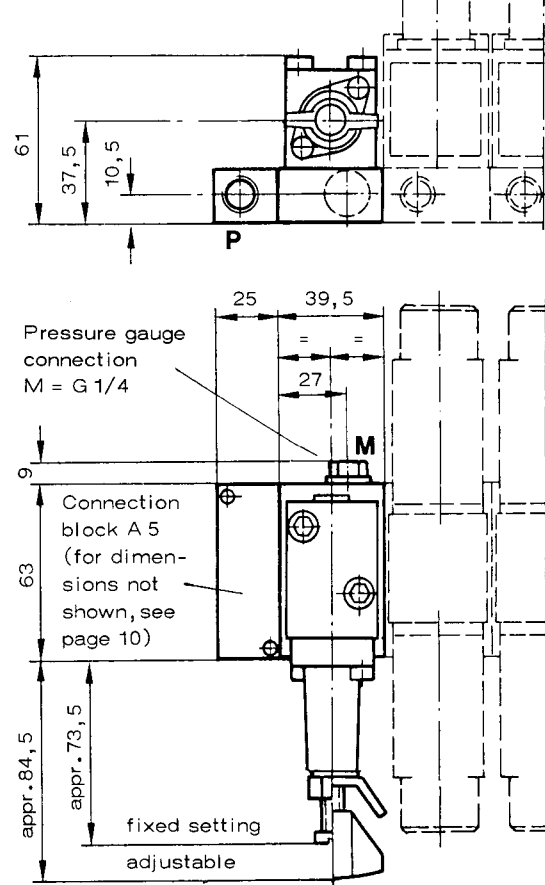

Type SWP 1... Z...

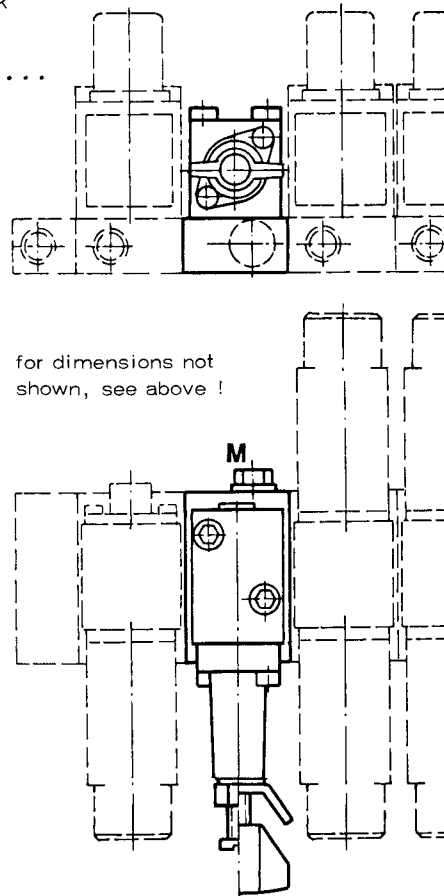

for dimensions not shown, see above !

5. Appendix

5.1. Connection block SWR 1 SE... FA... in accordance with Sect.4.1 Table 2

The functional parts of the 3-way proportional flow control valve type SEH3-2/..F in accordance with D 7557 are integrated into this connection block. This enables the operating speed of the connected consumers to be controlled steplessly and independently of the load pressure by regulating the delivery current. This is in addition to control of the direction in which they move. If necessary, this valve combination can replace a costly proportional directional valve block and represents a very reasonably priced alternative.

Coding example: SWR 1 **SE 10F A6** -GD -1- **G 24** - 150

refer to Sect.4.1

See Sect.4.4.1 for dimensions of units

Proportional solenoid $U_N$ <sup>3)</sup>	<b>G 12</b>	<b>G 24</b>
	12V DC	24V DC

Rated flow Control orifice, de-energized closed <sup>1)</sup> (standard version)	Control range Effective oil flow $Q_A$ appr. l/min from ... to	Symbol
<b>15F</b>	0,2 ... 15	
<b>SE 10F A6</b> <sup>2)</sup>	0,1 ... 10	
<b>6F A7</b> <sup>2)</sup>	0,1 ... 6	
<b>3F</b>	0,1 ... 3	

1) De-energized open (code letter F omitted) on request, but bear in mind restrict. in acc. with D 7557, Sect.2.1, footnote 1)

2) ... A 6 = press.limit.valve fixed setting  
... A 7 = press.limit. valve adjustable

3) SE... only available with proportional solenoid G12 or G24.

If this voltage does not correspond to the other valve solenoids, their voltage must be appended with a slash:

SWR 1 SE 10F A 6-GD-1-G 24 / WG 220

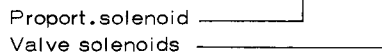

Q - I characteristic for consumer effective oil flow (approx. values)

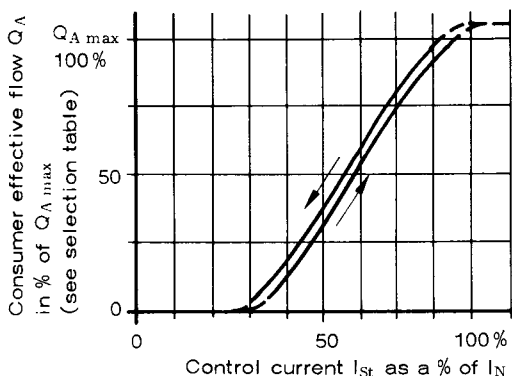

Oil viscosity during the measurement approx. 50 mm<sup>2</sup>/s

Proportional solenoid

Solenoid	in accordance with VDE 0580
Rated voltage $U_N$	12V or 24V DC
Coil resistance $R_{20}$	6,0 $\Omega$ at 12V, 24,0 $\Omega$ at 24V
Cold current $I_{20}$	2,0 A at 12V, 1,0 A at 24V
Rated current $I_N \approx 70\%$ of $I_{20}$	1,26 A at 12V, 0,63 A at 24V
Cold power $P_{20} = R_{20} \times I_{20}^2$	24,0 W
Rated power $P_N = R_{20} \times I_N^2$	9,5 W
Dither frequency	50 ... 150 Hz
Dither amplitude	20 ... 40% of $I_N$
Rel. duty cycle	100% duty cycle (ref. temp. $\vartheta_{11} = 50^\circ\text{C}$ )
Electrical connection	in accordance with DIN 43 650 B (industrial standard)
Protection class	solenoid IP 54; connection IP 65 with correctly fitted plug

5.2. BWN(H)1K- and BWH2K- fitting directional seated valves

The SWR1 valve blocks can be combined with BWN1- and BWH1- seated valve blocks in accord. with D 7470, the latter being connected to the SWR1 block instead of end plate -1-, Section 4.1, in the adapter plate version BWN(H)1K-... or BWH2K-... See dimensional sketch Sk 7550 H for BWN(1)K-... and Sk 7586 K for BWH2K-...

Circuit example: D 7470 Sect.4

SWR 1 A 6 -UGD - BWN1 **K** -HH - 1 - 1 - G 24 - 160

