

Restrictor check valve type BC

Product documentation



Screw-in valve

Operating pressure p_{\max} : 700 bar

Flow rate Q_{\max} : 60 lpm



© by HAWE Hydraulik SE.

The reproduction and distribution of this document as well as the use and communication of its contents to others without explicit authorisation is prohibited.

Offenders will be held liable for the payment of damages.

All rights reserved in the event of patent or utility model applications.

Brand names, product names and trademarks are not specifically indicated. In particular with regard to registered and protected names and trademarks, usage is subject to legal provisions.

HAWE Hydraulik respects these legal provisions in all cases.

Printing date / document generated on: 10.11.2017

Contents

1	Overview restrictor check valves type BC.....	4
2	Available versions, main data.....	5
3	Parameters.....	8
3.1	General.....	8
4	Dimensions.....	11
4.1	Creating the mounting hole.....	12
5	Assembly, operation and maintenance recommendations.....	13
5.1	Intended use.....	13
5.2	Assembly information.....	13
5.2.1	Creating the mounting hole.....	13
5.3	Operating instructions.....	14
5.4	Maintenance information.....	14

Restrictors are a type of flow valve. They are used as a local flow resistance that suddenly reduces the line cross-section. The reduction in the cross-section is very short. As a result the flow rate is only dependent on the pressure difference and not on the viscosity.

The restrictor check valve type BC combines the function of a metering valve with a check valve. The valve is available as a perforated restrictor or as a slotted restrictor. It limits the flow rate during the switching of directional valves. E.g. it limits the flow or prevents excessively quick accumulator emptying.

Features and benefits:

- Max. 700 bar
- Simple design and installation

Intended applications:

- General hydraulics
- Winch controls
- Hydraulic pilot systems

*Screw-in cartridge*

2 Available versions, main data

Order coding example:

BC 2	-0,8	
BC 1	-0,6	-G

Version Table 3 Version

Orifice Tabla 2 Orifice

Basic type and size Tabla 1 Basic type and size

Circuit symbol:

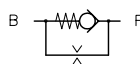
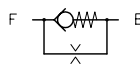

Section view:



Tabla 1 Basic type and size

Version with spring

Basic type and size	volumetric flow Q_p (lpm)	Pressure p_{max} (bar)	Thread	Opening pressure (bar)
BC 1	20	700	G 1/4 A (BSPP)	0.05 ... 0.07
BC 2	35	700	G 3/8 A (BSPP)	0.05 ... 0.07
BC 3	60	500	G 1/2 A (BSPP)	0.05 ... 0.07
BC 14	20	700	M 14x1.5	0.05 ... 0.07
BC 26	35	700	M 16x1.5	0.05 ... 0.07
BC 28	35	700	M 18x1.5	0.05 ... 0.07
BC 30	60	500	M 20x1.5	0.05 ... 0.07
BC 32	60	500	M 22x1.5	0.05 ... 0.07

Version without spring

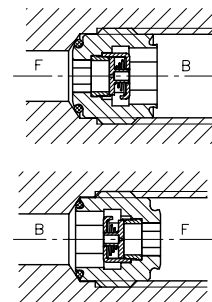
Basic type and size	volumetric flow Q_p (lpm)	Pressure p_{max} (bar)	Thread
BC 1 X	20	700	G 1/4 A (BSPP)
BC 2 X	35	700	G 3/8 A (BSPP)
BC 3 X	60	500	G 1/2 A (BSPP)
BC 14 X	20	700	M 14x1.5
BC 26 X	35	700	M 16x1.5
BC 28 X	35	700	M 18x1.5
BC 30 X	60	500	M 20x1.5
BC 32 X	60	500	M 22x1.5

Tabla 2 Orifice

Type	Slot-type throttle Depth in 1/1000 (mm)				
	20	30	40	60	80
BC 1 BC 14	●	●	●	●	●

	Orifice-Ø (mm)									
	0.2	0.4	0.5	0.6	0.8	1.0	1.2	1.5	1.8	2.0
BC 1 BC 14	●	●	●	●	●	●	●			
BC 2 BC 26 BC 28		●		●	●	●	●	●		
BC 3 BC 30 BC 32		●		●	●	●	●	●	●	●

	0.7	0.8	0.9	1.0	1.1	1.2	1.3	1.4	1.5	1.8
	BC 1 X	●	●	●	●	●	●	●	●	●
BC 14 X									●	
BC 2 X BC 26 X BC 28 X									●	●
BC 3 X BC 30 X BC 32 X										

	2.0	2.1	2.2	2.4	2.5	3.0	3.5	4.0
	BC 1 X	●				●		
BC 14 X	●				●			
BC 2 X BC 26 X BC 28 X	●	●	●	●	●			
BC 3 X BC 30 X BC 32 X	●				●	●	●	●

Table 3 Versions

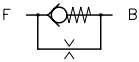
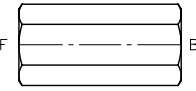
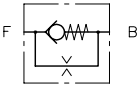
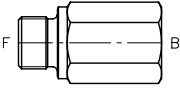
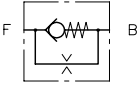
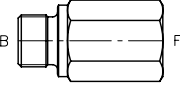
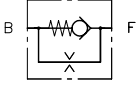
Design	Description	View	Circuit symbol
No coding	Cartridge valve		
G	Pipe connection on both sides		
E	Tapped journal on one end		
F			

3.1 General

Description	Restrictor check valves
Design	Type BC plate check valve, spring-loaded with valve plate in the form of perforated or slotted restrictor Type BC.X plate check valve, without spring with valve plate in the form of perforated restrictor
Design	Cartridge valve, version with housing
Material	Steel; hardened, ground functional inner parts
Flow direction	F → B Free flow
Hydraulic fluid	Hydraulic oil: according to Part 1 to 3; ISO VG 10 to 68 according to DIN ISO 3448 Viscosity limits: min. approx. 4, max. approx. 1500 mm ² /s opt. operation approx. 10... 500 mm ² /s. Also suitable for biologically degradable hydraulic fluids type HEPG (polyalkylene glycol) and HEES (synthetic ester) at operating temperatures up to approx. +70°C.
Cleanliness level	ISO 4406 <u>21/18/15...19/17/13</u>
Temperature	Ambient: approx. -40 ... +80°C, Fluid: -25 ... +80°C, Note the viscosity range! Permissible temperature during start: -40°C (observe start-viscosity!), as long as the service temperature is at least 20K higher for the following operation. Biologically degradable pressure fluids: Observe manufacturer's specifications. By consideration of the compatibility with seal material not over +70°C.

Curves

Oil viscosity approx. 62 mm²/s



Note

At viscosities above approx. 500 mm²/s the Δp values deviate increasingly upwards.

Throttled flow B → F

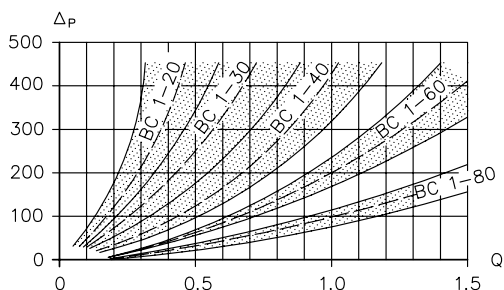

Q flow rate (lpm); Δp flow resistance (bar)

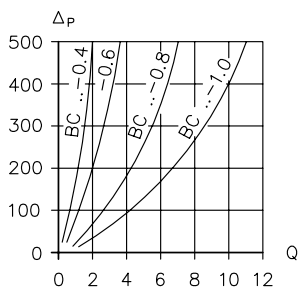

Q flow rate (lpm); Δp flow resistance (bar)

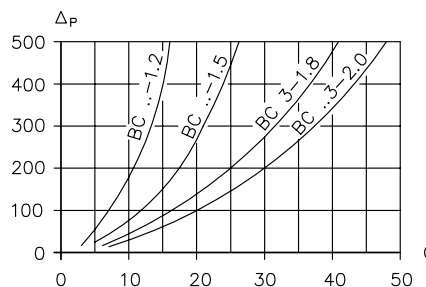

Q flow rate (lpm); Δp flow resistance (bar)

Free flow F → B

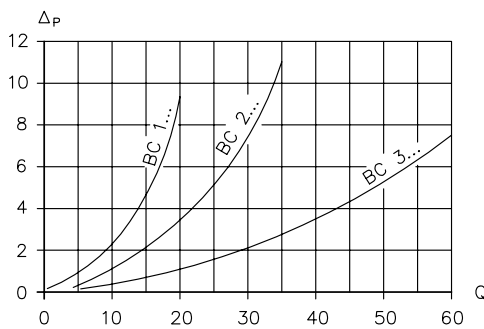

Q flow rate (lpm); Δp flow resistance (bar)

Weight**Screw-in cartridge****Type**

BC 1 (X), BC 14 (X)	= 6 g
BC 2 (X), BC 26 (X), BC 28 (X)	= 15 g
BC 3 (X), BC 30 (X), BC 32 (X)	= 25 g

Housing version**Type**

BC 1 .. - G	= 75 g
BC 2 .. - G	= 105 g
BC 3 .. - G	= 170 g
BC 1 .. - E, BC 1 .. - F	= 60 g
BC 2 .. - E, BC 2 .. - F	= 85 g
BC 3 .. - E, BC 3 .. - F	= 145 g

4 Dimensions

All dimensions in mm, subject to change.

Cartridge

Larger Allan key for installation (side B)

Smaller Allan key for installation (side F)

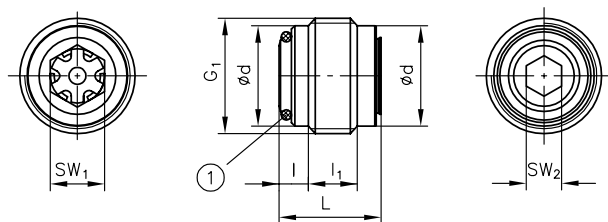

1 sealing ring



Note

Do not insert key with force during assembly to ensure the inner parts of the valve are not damaged.

Type	G ₁	L	l	l ₁	Ød	SW ₁	SW ₂	Sealing ring NBR 90 Sh	Max. torque M _A (Nm)
BC 1 (X)	G 1/4 A (BSPP)	13	3.5	6	11.6	8	4	9x1	9
BC 14 (X)	M 14x1.5	13	3.5	6	12.2	8	4	9x1	9
BC 2 (X)	G 3/8 A (BSPP)	15	4.3	7.2	14.8	9	5	10x1.5	15
BC 26 (X)	M 16x1.5	15	4.3	7.2	14.2	9	5	10x1.5	15
BC 28 (X)	M 18x1.5	15	4.3	7.2	16	9	5	10x1.5	15
BC 3 (X)	G 1/2 A (BSPP)	18	5	8	18.5	12	8	14x1.5	40
BC 30 (X)	M 20x1.5	18	5.5	7	18.2	12	8	14x1.5	40
BC 32 (X)	M 22x1.5	18	5	8	20	12	8	14x1.5	40

Version withhousing

BC ... G

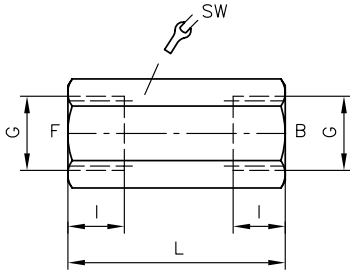

BC ... E, BC ... F

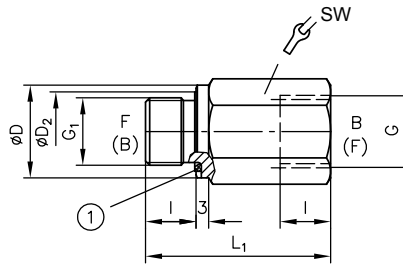

1 Thread seal

With type BC 1... with fitting seal G 1/4 (BSPP) NBR, all others with cutting edge

Type	G	G ₁	ØD	ØD ₂	L	L ₁	l	SW	Tightening torque (Nm)
BC 1 (X)	G 1/4 (BSPP)	G 1/4 A (BSPP)	19	--	46	43	12	19	40
BC 14 (X)	M 14x1,5	M 14x1,5	19	16	46	42	12	19	40
BC 2 (X)	G 3/8 (BSPP)	G 3/8 A (BSPP)	22	20,5	50	44	12	22	80
BC 26 (X)	M 16x1,5	M 16x1,5	22	20	50	44	12	22	80
BC 28 (X)	M 18x1,5	M 18x1,5	24	22	50	44	12	24	80
BC 3 (X)	G 1/2 (BSPP)	G 1/2 A (BSPP)	26	24	56	52	14	27	150
BC 30 (X)	M 20x1,5	M 20x1,5	25	24	56	52	14	27	150
BC 32 (X)	M 22x1,5	M 22x1,5	27	26	56	52	14	30	150

4.1 Creating the mounting hole

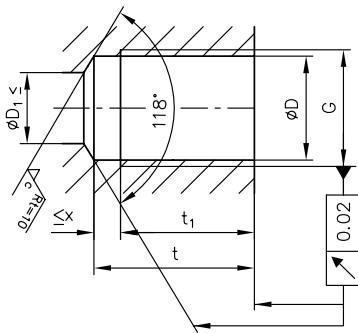

Type	G	ØD	ØD ₁	t	t ₁	x
BC 1 (X)	G 1/4 (BSPP)	11.8	8	25.5	22.5	3
BC 14 (X)	M 14x1.5	12.5	8	25.5	22.5	3
BC 2 (X)	G 3/8 (BSPP)	15.25	9	27	24	3
BC 26 (X)	M 16x1.5	14.5	9	27	24	3
BC 28 (X)	M 18x1.5	16.5	9	27	24	3
BC 3 (X)	G 1/2 (BSPP)	19	12	32.5	28.5	3.5
BC 30 (X)	M 20x1.5	18.5	12	32.5	28.5	3.5
BC 32 (X)	M 22x1.5	20.5	12	32.5	28.5	3.5

5 Assembly, operation and maintenance recommendations

5.1 Intended use

This valve is exclusively intended for hydraulic applications (fluid engineering).

The valve demands high technical safety standards and regulations for fluid engineering.

The user must observe the safety measures and warnings in this documentation.

Essential requirements for the product to function correctly and safely:

- All information in this documentation must be observed. This applies in particular to all safety measures and warnings.
- The product must only be assembled and put into operation by qualified personnel.
- The product must only be operated within the specified technical parameters. The technical parameters are described in detail in this documentation.
- The operating and maintenance manual of the specific complete system must also always be observed.

If the product can no longer be operated safely:

1. Remove the product from operation and mark it accordingly
- ✓ It is then not permissible to continue using or operating the product

5.2 Assembly information

The product must only be installed in the complete system with standard and compliant connection components (screw fittings, hoses, pipes, etc.).

The hydraulic power pack must be shut down correctly prior to dismantling; this applies in particular to power packs with hydraulic accumulators.



Danger

Risk to life caused by sudden movement of the hydraulic drives when dismantled incorrectly!

Risk of serious injury or death.

- Depressurise the hydraulic system.
- Perform safety measures in preparation for maintenance.

5.2.1 Creating the mounting hole

See description in [Chapter 4, "Dimensions"](#).

5.3 Operating instructions

Product configuration and setting the pressure and flow rate

The statements and technical parameters in this documentation must be strictly observed.
The instructions for the complete technical system must also always be followed.

Note

- Read the documentation carefully before usage.
- The documentation must be accessible to the operating and maintenance staff at all times.
- Keep documentation up to date after every addition or update.



Caution

Risk of injury due to unexpected movement processes in the machine due to incorrect flow setting!

Risk of minor injury

- Be prepared for unexpected, fast movements. On changing the flow settings, consumers will move more slowly or more quickly.
- Always monitor the pressure gauge when setting or changing the flow.

Purity and filtering of the hydraulic fluid

Fine contamination can significantly impair the function of the hydraulic component. Contamination can cause irreparable damage.

Examples of fine contamination include:

- Metal chips
- Rubber particles from hoses and seals
- Dirt due to assembly and maintenance
- Mechanical debris
- Chemical ageing of the hydraulic fluid

Note

Fresh hydraulic fluid from the drum does not always have the highest degree of purity. Under some circumstances the fresh hydraulic fluid must be filtered before use.

Pay attention to the cleanliness level of the hydraulic fluid in order to maintain faultless operation.
(Also see cleanliness level in [Chapter 3, "Parameters"](#)).

5.4 Maintenance information

This product is largely maintenance-free.

Conduct a visual inspection at regular intervals, but at least once per year, to check if the hydraulic connections are damaged. If external leakages are found, shut down and repair the system.

Clean the device surface of dust deposits and dirt at regular intervals, but at least once per year.

Further information

Additional versions

- Check valves, type RC: D 6969 R
- Pressure-reducing valve type CDK: D 7745
- Check valve type RE: D 7555 R
- Check valve type CRK, CRB and CRH: D 7712