

Check valve type CRK, CRB and CRH

Product documentation



Screw-in valve

Operating pressure p_{\max} : 500 bar

Flow rate Q_{\max} : 80 lpm



© by HAWE Hydraulik SE.

The forwarding and reproduction of this document, as well as the use and communication of its contents, are forbidden unless expressly permitted.

Any breach or infringement will result in liability for damages.

All rights reserved concerning patent or utility model application.

Contents

1	Overview of check valve type CRK, CRB and CRH.....	4
2	Available versions, main data.....	5
2.1	Screw-in valves (basic version).....	5
2.2	Version with single connection block.....	6
3	Parameters.....	7
4	Dimensions.....	10
4.1	Screw-in valves (basic version).....	10
4.1.1	Type CRK, CRB.....	10
4.1.2	Type CRH.....	11
4.2	Mounting hole.....	12
4.3	Version with single connection block.....	14
4.4	Tapped plugs.....	15
5	Assembly, operation and maintenance recommendations.....	16
5.1	Intended application.....	16
5.2	Assembly information.....	17
5.2.1	Screwing in the screw-in valve (basic version).....	17
5.2.2	Creating the mounting hole.....	17
5.3	Operating instructions.....	18
5.4	Maintenance information.....	18
6	Other information.....	19
6.1	Schematic diagram.....	19

Check valves are a type of non-return valve. They block the oil flow in one direction and open in the opposite direction. In the closed state they have zero leakage.

The check valve types CRK, CRB and CRH can be screwed-in and can be integrated into manifolds. The necessary mounting holes are straightforward to make.

Features and benefits:

- Screw-in valves

Intended applications:

- General hydraulic systems

Check valves type CRK and CRB

- The valves enable free flow in one direction and block it in the opposite direction.
- Type CRK blocks in direction $B \rightarrow A$, type CRB blocks in direction $A \rightarrow B$.
- The check valves are not to be used for continual successive load alternation.

Releasable check valves type CRH

- The valves enable free flow in one direction ($B \rightarrow A$) and block it in the opposite direction ($A \rightarrow B$). The blocked flow direction ($A \rightarrow B$) can be released (opened) using hydraulic control.
- **Application**
 - For airtight blocking (pressure maintenance) of zero-leakage hydraulic cylinders in conjunction with directional valves (spools) suffering from leaking oil.
 - As return flow relief if return oil flows that are greater than the permissible flow rate for the directional valve are experienced due to the surface ratio, when introducing a double-acting hydraulic cylinder.
 - As a hydraulically actuated drain or idle circulation valve.
- Upon hydraulic release of the valves, the full flow cross section is quickly cleared. To avoid abrupt opening at high pressures and the relief surges which may arise as a result, the control channel in the basic body should be designed with the smallest possible diameter, so as to retain the character of a throttle line. With size 3, a throttle point is already provided at the Z input. For high pressures and large consumer volumes, size 3 is also available with hydraulic release. With this version, a small check valve is opened before the main valve during the release procedure which releases a throttling cross-section, via which the consumer pressure can decrease sufficiently surge-free. Additional throttling of the control channel increases the effectiveness of the hydraulic release.



Check valve type CRK and CRB



Releasable check valve type CRH

2 Available versions, main data

2.1 Screw-in valves (basic version)

Circuit symbol:

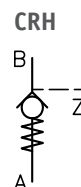
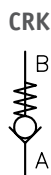

Order coding example:

CRH 2
 CRH 3 V

Basic type and size Table 1 Basic type and size

Table 1 Basic type and size

Basic type and size	Description	Pressure p_{max} (bar)	Flow rate Q_{max} (lpm)	Spigot screw thread, metric ISO fine thread DIN 13 T6	Pilot ratio			
					Main valve	Hydraulic release		
CRK 1	Check valve	500	30	M16x1.5	--	--		
CRK 1/1.3								
CRK 2								
CRK 3			80	M24x1.5				
CRB 1							30	M16x1.5
CRB 2								
CRH 1	20		M16x1.5	2.6:1				
CRH 2					30	M20x1.5		
CRH 3								
CRH 3V	Releasable check valve with hydraulic release		55	M24x1.5			2.5:1	10:1
CRH 11	Releasable check valve with additional thread and control piston sealing		20	M16x1.5	2.6:1	--		
CRH 21			30	M20x1.5				
CRH 31		55	M24x1.5	2.5:1				
CRH 31V							10:1	

2.2 Version with single connection block

Order coding example:

CRK 1 - 1/4

Single connection block Table 2 Version with single connection block

Basic type and size Table 1 Basic type and size

Table 2 Version with single connection block

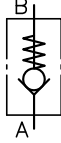
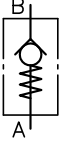
Coding	Description	For type	Circuit symbol
- 1/4	Pipe connection, G 1/4 DIN EN ISO 228-1	CRK 1. CRB 1.	<div style="display: flex; justify-content: space-around;"> <div style="text-align: center;"> <p>CRK</p>  </div> <div style="text-align: center;"> <p>CRB</p>  </div> </div>
- 3/8	Pipe connection, G 3/8 DIN EN ISO 228-1	CRK 1. CRB 1.	

3 Parameters

General information

Designation	Spring-loaded check valve
Design	Type CRK, CRH - Ball seated valve Type CRB - Plate valve
Model	Screw-in valve, valve for pipe connection
Material	Steel; nitrided valve housing, electrogalvanised sealing nuts and connection block, hardened and ground functional inner parts Balls made of rolling bearing steel
Tightening torque	See Chapter 4, "Dimensions"
Installation position	As desired
Ports	A, B = working connections Z = control connection for type CRH Applies to circuit diagrams and assembly plans only. Can be found in the schematic overviews Chapter 1, "Overview of check valve type CRK, CRB and CRH" or in the dimension diagrams Chapter 4, "Dimensions" . The characters are not applied to the valve housings.
Flow direction	Type CRK: A → B free B → A blocked CRB: A → B blocked B → A free CRH: B → A free A → B blocked with zero leakage in idle position (Z port depressurised) if there is no pressure at B or the pressure is lower than at A A → B free if, at Z, the valve is released through the control pressure (see also control pressure p_{st})
Hydraulic fluid	Hydraulic oil: according to Part 1 to 3; ISO VG 10 to 68 according to DIN ISO 3448 Viscosity limits: min. approx. 4, max. approx. 1500 mm ² /s opt. operation approx. 10... 500 mm ² /s. Also suitable for biologically degradable hydraulic fluids type HEPG (polyalkylene glycol) and HEES (synthetic ester) at operating temperatures up to approx. +70°C.
Cleanliness level	ISO 4406 <hr/> 21/18/15...19/17/13
Temperatures	Ambient: approx. -40 ... +80°C, Fluid: -25 ... +80°C, Note the viscosity range! Permissible temperature during start: -40°C (observe start-viscosity!), as long as the service temperature is at least 20K higher for the following operation. Biologically degradable pressure fluids: Observe manufacturer's specifications. By consideration of the compatibility with seal material not over +70°C.

Pressure and flow rate

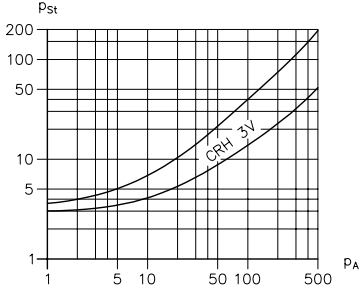
Operating pressure	$p_{max} = 500 \text{ bar}$	
Static overload capacity	Approx. $2 \times p_{max}$ when tightened and locked with a sealing nut	
For type CRH leakage oil between Z and B	Type CRH 1, CRH 2, CRH 3, CRH 3V: Type CRH 11, CRH 21, CRH 31, CRH 31V:	Low leakage through thread turns present; no influence on the influence on the blocked consumer side A Not present
Opening pressure A → B or B → A	Type CRK: Approx. 0.5 bar CRK 1/1.3: Approx. 1.3 bar CRB: Approx. 0.07 to 0.1 bar CRH: Approx. 0.5 bar	
Control pressure p_{st} (reference values) for type CRH	For releasing  p_{st} control pressure (bar); p_A pressure (bar)	For holding open $p_{st} = p_B + \Delta p + k$ p_B = pressure on B side Δp = Flow resistance A → B according to Δp -Q characteristics k = 4.5 type CRH 1 4.0 type CRH 2 2.5 type CRH 3

Characteristic curves

Oil viscosity approx. $60 \text{ mm}^2/\text{s}$

Δp -Q characteristics

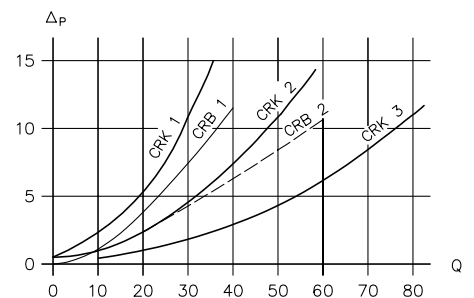
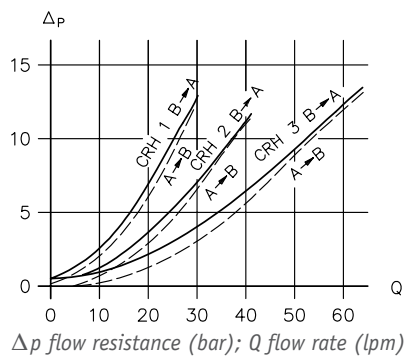

Weight**Type**

CRK 1	= 70 g
CRK 2	= 110 g
CRK 3	= 130 g
CRB 1	= 70 g
CRB 2	= 110 g
CRH 1	= 60 g
CRH 2	= 90 g
CRH 3	= 150 g
CRH 3V	= 150 g

Connection blocks

- 1/4	= +260 g
- 3/8	= +260 g

4 Dimensions

All dimensions in mm, subject to change.

4.1 Screw-in valves (basic version)

4.1.1 Type CRK, CRB

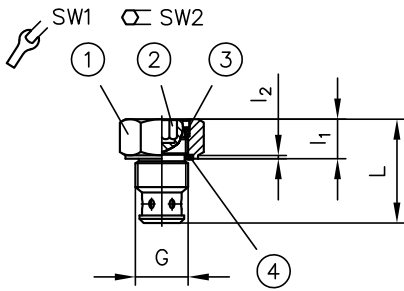

- 1 Sealing nut
- 2 Screw part
- 3 O-ring
- 4 Fitting seal

Type	G	L	l ₁	l ₂
CRK 1. CRB 1	M16x1.5	31	12	1
CRK 2 CRB 2	M20x1.5	35	13	1
CRK 3	M24x1.5	38	14	1.5

Type	SW1	SW2	Tightening torque (Nm)		Fitting seal	O-ring AU 90 Sh
			SW1	SW2		
CRK 1. CRB 1	22	8	40	35	KANTSEAL DKAR00016-N90	14x1.78
CRK 2 CRB 2	24	10	50	40	KANTSEAL DKAR00018-N90	17.17x1.78
CRK 3	30	12	70	60	KANTSEAL DKAR00021-N90	21.95x1.78

SW = a/f

4.1.2 Type CRH

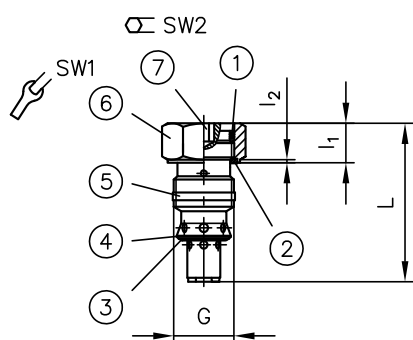

- 1 O-ring
- 2 Fitting seal
- 3 O-ring
- 4 Sealing edge
- 5 Additional sealing ring for type CRH 11, CRH 21, CRH 31, CRH 31V
- 6 Sealing nut
- 7 Screw part

Type	G	L	l ₁	l ₂
CRH 1 CRH 11	M16x1.5	47	12	1
CRH 2 CRH 21	M20x1.5	53	13	1
CRH 3 CRH 31 CRH 3V CRH 31V	M24x1.5	61	14	1.5

Type	SW1	SW2	Tightening torque (Nm)		Fitting seal	O-ring ①	O-ring ③	Sealing ring for CRH 1
			SW1	SW2		AU 90 Sh	NBR 90 Sh	
			CRH 1 CRH 11	22		8	35	
CRH 2 CRH 21	24	10	40	50	KANTSEAL DKAR00018-N90	17.17x1.78	12.42x1.78	7735 013
CRH 3 CRH 31 CRH 3V CRH 31V	30	12	60	70	KANTSEAL DKAR00021-N90	21.95x1.78	15.3x2.4	7735 023

SW = a/f

4.2 Mounting hole

Type CRK, CRB

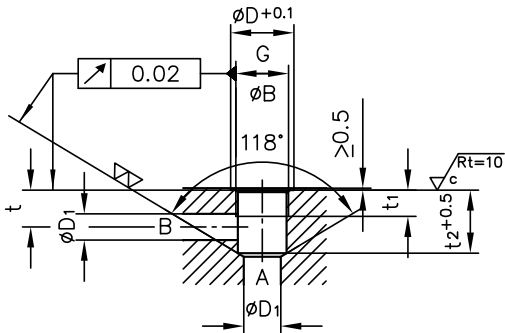

Note

For tapped plugs for the mounting holes, see [Chapter 4.4, "Tapped plugs"](#).

Type	G	Counterbore $\varnothing B_{\max}$	$\varnothing D$	$\varnothing D_1$	t	t ₁	t ₂
CRK 1. CRB 1	M16x1.5	16 ^{+0.2}	22	8	13	11	18
CRK 2 CRB 2	M20x1.5	20 ^{+0.2}	24	10	14	13	20
CRK 3	M24x1.5	24 ^{+0.2}	30	11	16	13	22

Type CRH

CRH 1, CRH 2, CRH 3, CRH 3V

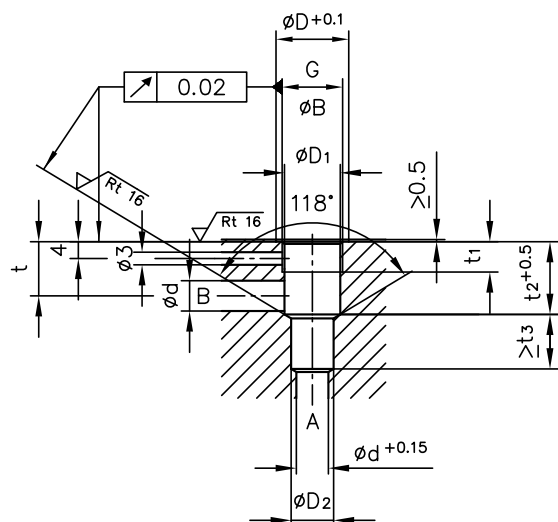

CRH 11, CRH 21, CRH 31, CRH 31V

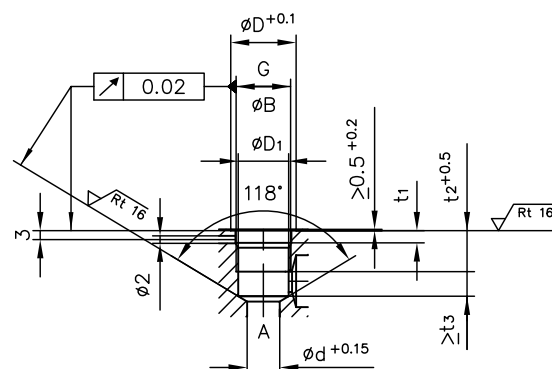

Note

For tapped plugs for the mounting holes, see [Chapter 4.4, "Tapped plugs"](#).

Type	G	Counterbore $\varnothing B_{\max}$	$\varnothing D$	$\varnothing D_1$	$\varnothing D_2$	$\varnothing d$	t	t_1	t_2	t_3
CRH 1	M16x1.5	$16^{+0.2}$	22	14.3	11	8	17	13	22	13
CRH 2	M20x1.5	$20^{+0.2}$	24	18.3	14	10	18	15	24	17
CRH 3 CRH 3V	M24x1.5	$24^{+0.2}$	30	22.3	16	11	21	16	28	19
CRH 11	M16x1.5	16.5	22	14.5	--	11	--	4	15	9
CRH 21	M20x1.5	20.5	24	18.2	--	12	--	4.5	15	9
CRH 31 CRH 31V	M24x1.5	24.5	30	22.5	--	16	--	5.5	16	12

4.3 Version with single connection block

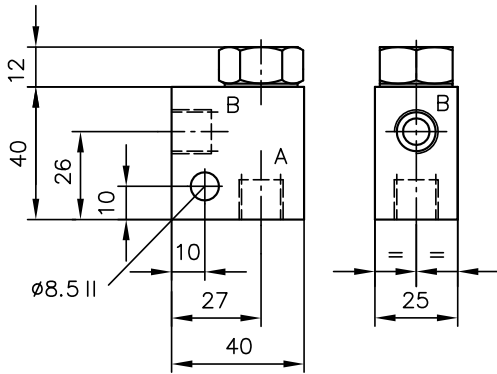

Type	Ports A, B	
CRK 1 CRB 1	- 1/4	G 1/4 (BSPP)
CRK 1 CRB 1	- 3/8	G 3/8 (BSPP)

4.4 Tapped plugs

The mounting holes can be sealed with tapped plugs if necessary; for example, if the assembly of standardised basic bodies is to be carried out with or without screw-in valves as required.

Passage open

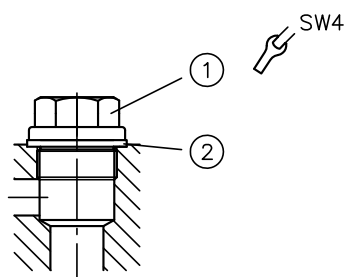

- 1 Tapped plug
- 2 Sealing ring

Passage blocked

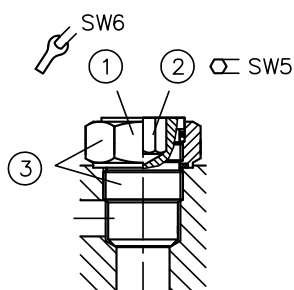

- 1 Lock nuts and sealing nuts
- 2 Screw part
- 3 Tapped plug and locking tapped plug complete

Type and size	Passage open				Passage blocked				
	Tapped plug			Sealing ring	Tapped plug and locking tapped plug complete				
	DIN 910	SW4	Tightening torque (Nm)	DIN 7603-Cu	Drawing no.	Screw part		Lock nuts and sealing nuts	
						SW5	Tightening torque (Nm)	SW6	Tightening torque (Nm)
CRK 1. CRB 1	M16x1.5	17	40	A16x22x1.5	Z 7712 003	8	40	22	35
CRH 1 CRH 11					Z 7735 011				
CRK 2 CRB 2	M20x1.5	19	50	A20x24x1.5	Z 7712 013	10	50	24	40
CRH 2 CRH 21					Z 7715 019				
CRK 3	M24x1.5	22	70	A25x30x2	Z 7710 029	12	70	30	60
CRH 3					Z 7715 029				
CRH 3V CRH 31 CRH 31V									
Weight	M16x1.5 + sealing ring = approx. 40 g M20x1.5 + sealing ring = approx. 60 g M24x1.5 + sealing ring = approx. 100 g				Z 7712 003 = 60 g Z 7735 011 = 65 g Z 7712 013 = 85 g Z 7715 019 = 95 g Z 7710 029 = 140 g Z 7715 029 = 140 g				

5.1 Intended application

This valve is intended exclusively for hydraulic applications (fluid engineering). The valve meets high technical safety standards and regulations for fluid and electrical engineering.

The user must observe the safety measures and warnings in this documentation.

Essential requirements for the product to function correctly and safely:

- All information in this documentation must be observed. This applies in particular to all safety measures and warnings.
- The product must only be assembled and put into operation by qualified personnel.
- The product must only be operated within the specified technical parameters. The technical parameters are described in detail in this documentation.
- The operating and maintenance manual of the specific complete system must also always be observed.

If the product can no longer be operated safely:

Remove the product from operation and mark it accordingly. It is then not permitted to continue using or operating the product.

5.2 Assembly information

The product must only be installed in the complete system with standard connection components that comply with market requirements (screw fittings, hoses, pipes, etc.).

The hydraulic system must be shut down correctly prior to dismantling; this applies in particular to hydraulic systems with hydraulic accumulators.



Danger

Risk to life caused by sudden movement of the hydraulic drives when dismantled incorrectly!

Risk of serious injury or death.

- Depressurise the hydraulic system.
- Perform safety measures in preparation for maintenance.

5.2.1 Screwing in the screw-in valve (basic version)

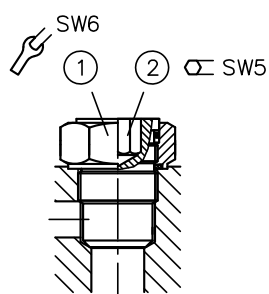

- 1 Lock nuts and sealing nuts
2 Valve

1. Before screwing in the valve, loosen the lock nut and sealing nut until the travel stop.
2. Screw in the valve and tighten to the specified torque. The metallic sealing of the inlet to the outlet is formed between the facial sealing edge of the valve and the shoulder of the stepped hole in the basic body.
3. Tighten the counter/sealing nut to the specified torque.

Type	Valve		Lock nuts and sealing nuts	
	SW5	Tightening torque (Nm)	SW6	Tightening torque (Nm)
CRK 1. CRB 1 CRH 1 CRH 11	8	40	22	35
CRK 2 CRB 2 CRH 2 CRH 21	10	50	24	40
CRH 3 CRH 3 CRH 3V CRH 31 CRH 31V	12	70	30	60

5.2.2 Creating the mounting hole

See description in [Chapter 4, "Dimensions"](#).

5.3 Operating instructions

Product configuration and setting the pressure and flow rate

The statements and technical parameters in this documentation must be strictly observed.
The instructions for the complete technical system must also always be followed.

Note

- Read the documentation carefully before usage.
- The documentation must be accessible to the operating and maintenance staff at all times.
- Keep documentation up to date after every addition or update.

Purity and filtering of the hydraulic fluid

Fine contamination can significantly impair the function of a hydraulic power pack. Contamination can cause irreparable damage.

Examples of fine contamination include:

- Metal chips
- Rubber particles from hoses and seals
- Dirt due to assembly and maintenance
- Mechanical debris
- Chemical ageing of the hydraulic fluid

Note

Fresh hydraulic fluid from the drum does not always have the highest degree of purity. Under some circumstances the fresh hydraulic fluid must be filtered before use.

Pay attention to the cleanliness level of the hydraulic fluid in order to maintain faultless operation.
(Also see cleanliness level in [Chapter 3, "Parameters"](#).)

5.4 Maintenance information

This product is largely maintenance-free.

Check that the product is securely fastened in the mounting hole at regular intervals, but at least once per year.

Conduct a visual inspection at regular intervals, but at least once per year, to check if the hydraulic connections are damaged. If external leakages are found, shut down and repair the system.

Clean the device surface of dust deposits and dirt at regular intervals, but at least once per year.

6 Other information

6.1 Schematic diagram

CRK

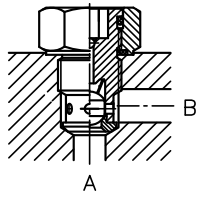

CRB

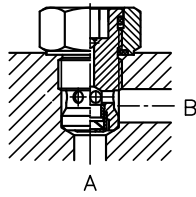

CRH

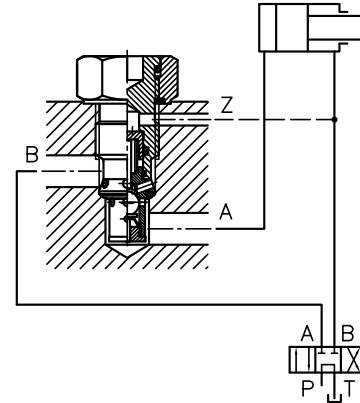
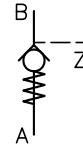

Further information

Additional versions

- Pressure valve type CMV, CMVZ, CSV and CSVZ: D 7710 MV
- Pressure-controlled shut-off valve type CNE: D 7710 NE
- Throttle valve and shut-off valve CAV: D 7711
- Throttle valve and throttle check valve type CQ, CQR and CQV: D 7713
- Flow control valve type CSJ: D 7736
- Pressure-reducing valve type CDK: D 7745
- Pressure-dependent shut-off valve type CDSV: D 7876
- Check valve type RK and RB: D 7445
- Check valves, type RC: D 6969 R
- Check valve type RE: D 7555 R
- Releasable check valve type RHC and RHCE: D 7165
- Restrictor check valve type BC: D 6969 B
- Restrictor check valve type BE: D 7555 B