

Directional spool valve bank type DL

Product documentation

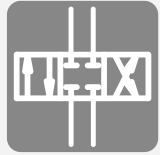

Operating pressure p_{\max} :

315 bar

Flow rate Q_{\max} :

30 lpm



D 7260/1

02-2023 -1.0 en

HAWE
HYDRAULIK

© by HAWE Hydraulik SE.

The reproduction and distribution of this document, as well as the use and communication of its contents to others without explicit authorization, is prohibited.

Offenders will be held liable for the payment of damages.

All rights reserved in the event of patent or utility model applications.

Brand names, product names and trademarks are not specifically indicated. In particular with regard to registered and protected names and trademarks, usage is subject to legal provisions.

HAWE Hydraulik respects these legal provisions in all cases.

HAWE Hydraulik cannot provide individual guarantees that the stated circuits or procedures (including in part) are not subject to the intellectual property rights of third parties.

Printing date / document generated on: 2023-02-27

Table of Contents

1	Overview of directional spool valve bank type DL.....	4
1.1	Configuration example.....	5
2	Available versions.....	6
2.1	Connection block.....	6
2.1.1	Basic type and size.....	6
2.1.2	Pressure-limiting valve.....	7
2.2	Valve section.....	8
2.2.1	Basic type and size.....	8
2.2.2	Consumer ports.....	8
2.2.3	Circuit symbols.....	9
2.2.4	Actuation.....	10
2.2.4.1	Manual actuation without contact switch.....	10
2.2.4.2	Manual actuation with contact switch.....	11
2.2.5	Mounting type.....	15
2.3	End plate.....	16
3	Parameters.....	17
3.1	General data.....	17
3.2	Pressure and volumetric flow.....	17
3.3	Weight.....	18
3.4	Characteristic lines.....	18
3.5	Electrical data Contact switch.....	21
4	Dimensions.....	22
4.1	Connection block.....	22
4.2	Valve section.....	24
4.3	Actuation.....	26
4.3.1	Manual actuation with spring return.....	26
4.3.2	Manual actuation with detent.....	28
4.4	Mounting type.....	30
4.5	End plate.....	33
5	Installation, operation and maintenance information.....	34
5.1	Intended use.....	34
5.2	Assembly information.....	34
5.3	Operating instructions.....	34
5.4	Maintenance information.....	35

1**Overview of directional spool valve bank type DL**

Directional spool valves are a type of directional valve. They control the direction of movement and the velocity of single and double-acting hydraulic consumers.

Throttling directional spool valves are a type of directional valve. They continuously and manually control the flow rate in hydraulic systems with single and double-acting consumers.

The throttling directional spool valve type DL influences the speed of the consumer by throttling the pump circulation via a parallel circuit (bypass control). The close fit of the spool in the throttling directional spool valve means that the leakage is limited to a minimum for lifting functions. The throttling directional spool valve type DL is suitable for applications in material handling and for lifting equipment.

Features and advantages

- Compact design
- Various actuation variants for manual actuation
- Up to 10 segments can be mounted in series connection
- Combinations possible for controlling lifting devices

Intended applications

- Industrial vehicles
- Machines for agricultural and forestry purposes
- Construction and construction materials machinery
- Road vehicle



Directional spool valve bank type DL

1.1 Configuration example

DL 11 -1 GDBNN-B/E 2 -2 -210

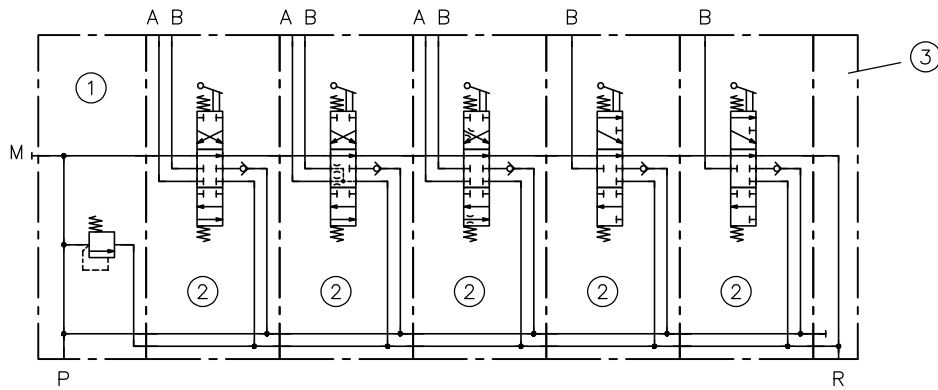

- 1 Connection block
- 2 Valve section
- 3 End plate

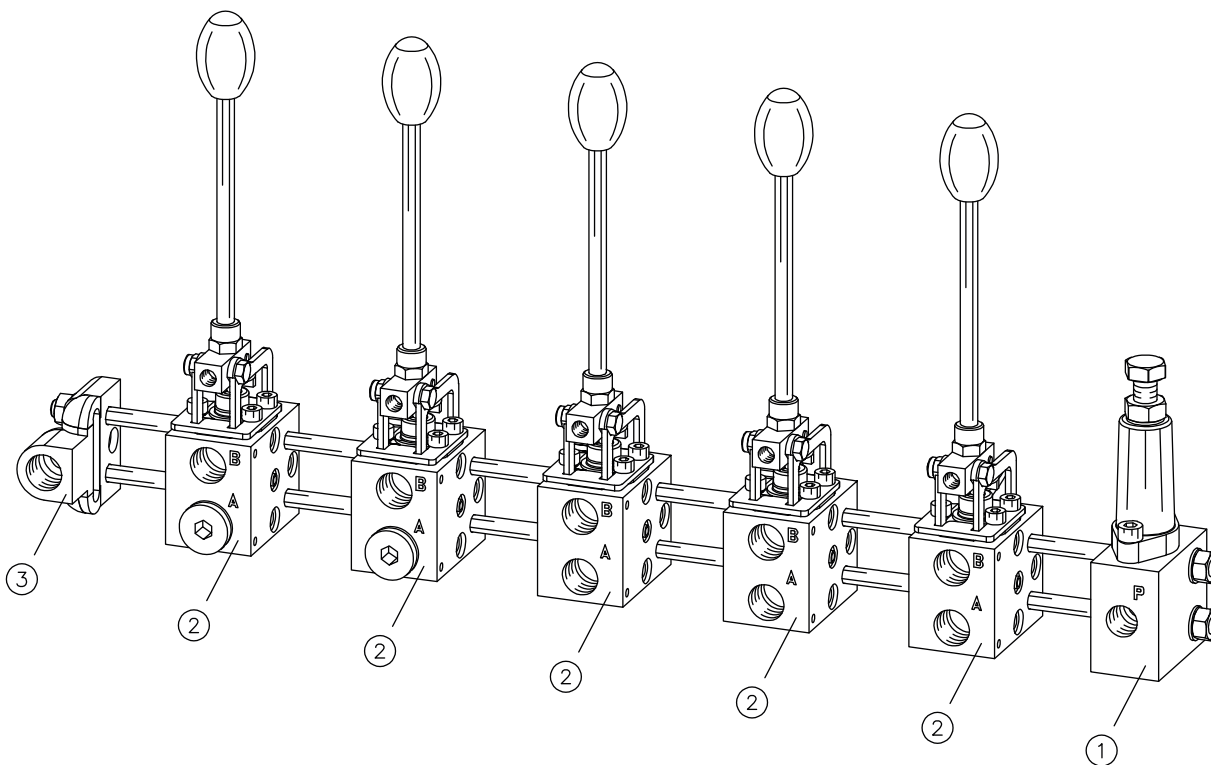

2 Available versions

Ordering example

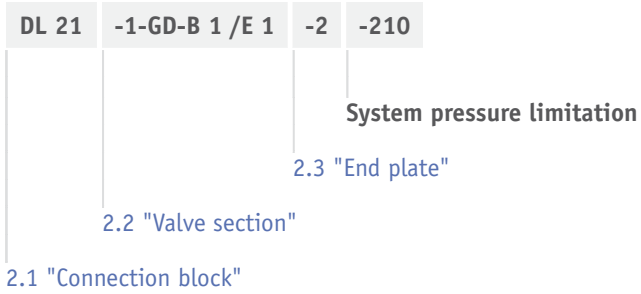

2.1 Connection block

Ordering example

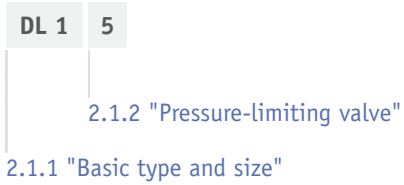

2.1.1 Basic type and size

Type	Ports (ISO 228-1)	Flow rate Q_{max} (lpm)	Pressure p_{max} (bar)
	P		
DL 1	G 1/4	12 ... 16	315
DL 2	G 3/8	20 ... 30	315

2.1.2 Pressure-limiting valve

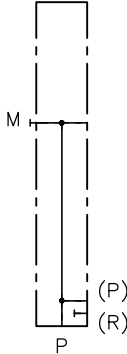
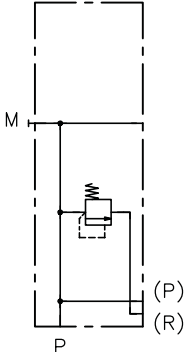
Coding	Description	Circuit symbol
5	Without pressure-limiting valve	
1	With pressure-limiting valve Pressure setting in bar. Adjustment range depending on spring <ul style="list-style-type: none"> ▪ 10 to 160 bar ▪ 10 to 250 bar ▪ 10 to 315 bar 	

2.2 Valve section

A manifold can merge up to 10 valve sections.

Ordering example

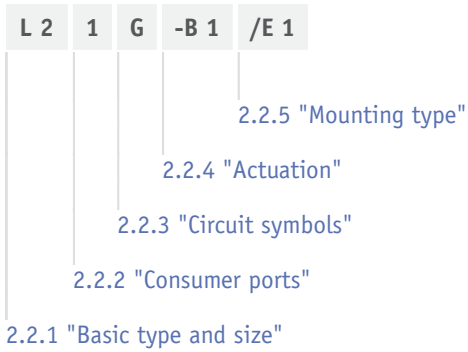

2.2.1 Basic type and size

Type	Description
L 1	Single valve section, size 1
L 2	Single valve section, size 2

NOTICE

L 1 or L 2 must only be specified in the order coding when ordering single valve sections.

2.2.2 Consumer ports

Coding	Description	Port	Port size (ISO 228-1)
1	Only in conjunction with connection block coding DL 1 or DL 2 (Chapter 2.1.1, "Basic type and size")	A, B	G 1/4
2	Only in conjunction with connection block coding DL 2 (Chapter 2.1.1, "Basic type and size")	A, B, H	G 3/8

2.2.3 Circuit symbols

Coding	Description	Circuit symbol		
G, D, E	4/3-way directional spool valve for use with double-acting consumers	G	D	E
B	4/3-way directional spool valve with additional outflow pressure for use with double-acting consumers Common applications: Stabilising cylinders with dragging loads, especially when used with load-holding valves or when used without additional check valves.	B		
N, R	3/3-way directional spool valve for use with single-acting consumers Depending on size and mounting type, port A or B can be sealed (see Chapter 4.2, "Valve section")	N	R	
A, P	3/3-way directional spool valve with narrow fitting tolerance for use with single-acting consumers. Common applications: Hydraulic cylinders for industrial vehicles To ensure that the return pressure is as low as possible, and that there is therefore as low a counter-pressure as possible when lowering with a low dead weight or load, the A or P spool should always be used in the last valve section, directly before the end plate. Only in conjunction with <ul style="list-style-type: none"> Connection block coding DL 2 (Chapter 2.1.1, "Basic type and size") Consumer ports coding 2 (Chapter 2.2.2, "Consumer ports") 	A	P	

2.2.4 Actuation

2.2.4.1 Manual actuation without contact switch

Coding	Description	Circuit symbol
B, B 1	Manual actuation with spring return <ul style="list-style-type: none"> ▪ B 1: without hand lever 	
C, D	Manual actuation with detent <ul style="list-style-type: none"> ▪ C: Version with detent for switching positions a and b ▪ D: Version with detent for switching position b, spring return for switching position a 	<div style="display: flex; justify-content: space-around;"> <div style="text-align: center;"> <p>C</p> </div> <div style="text-align: center;"> <p>D</p> </div> </div>

! NOTICE

For valve banks with a mix of actuation types, the individual actuation coding B, C or D should be arranged in the same sequence as the spools to which they belong.

Ordering example: DL 21-2-**GGR-BCD**/E 1-3-180

2.2.4.2 Manual actuation with contact switch

Manual actuation with spring return and contact switch

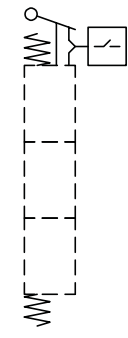
Coding	Description	Circuit symbol
B 4 B 5	Actuation with contact switch type SEK 103/S/PG11K from ELAN Protection class: IP 67 – Only in conjunction with connection block coding DL 2 (Chapter 2.1.1, "Basic type and size") ▪ B 5 : without hand lever	
B 4 S B 5 S	Actuation with contact switch type V 3S with roller actuation type VLR 1 from Burgess Protection class: IP 67 – Only in conjunction with circuit symbols G, D, E, B, N, R (Chapter 2.2.3, "Circuit symbols") ▪ B 5 S : without hand lever	
B 40 B 50	Actuation with contact switch type XGG2-88-S20Z1 with roller actuation type S20 from Sicatron Protection class: IP 40 – Only in conjunction with circuit symbols G, D, E, B, N, R (Chapter 2.2.3, "Circuit symbols") ▪ B 50 : without hand lever	

Manual actuation with spring return and provision made for contact switch

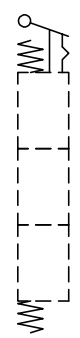
Coding	Description	Circuit symbol
B 6 B 7	– Without switch or switch retainer – With switching curve ▪ B 7 : without hand lever	
B 8 B 9	– Without switch – With switching curve and switch retainer for contact switch type B 4 S, B 5 S or B 40, B 50 – Not available for circuit symbol R and P ▪ B 9 : without hand lever	
B 81 B 91	– Without switch – With switching curve and switch retainer for contact switch type B 4 and B 5 – Only for DL 2 ▪ B 91 : without hand lever	

2.2.4.2.1 Contact switch set-up

Version B 4, B 5, B 6, B 7, B 81 and B 91

The switch can be adjusted on the switch retainer so that in switching positions a or b the contact bridges 11 - 12 or 23 - 24 can be used as N/O contacts or N/C contacts, as required.

Circuit symbol G, B, D, E, N, A

Switch is not set up adjusted. It is to be adjusted as needed when it is electrically connected to its switch retainer. The switch is pressed in the spool valve neutral position; for circuit symbols N and A it is also pressed in position a.

Neutral position

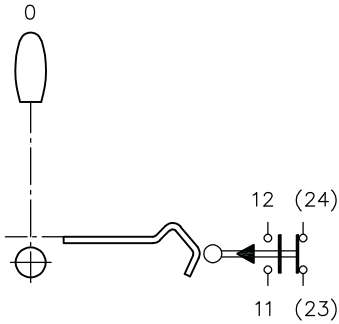

Position a or b

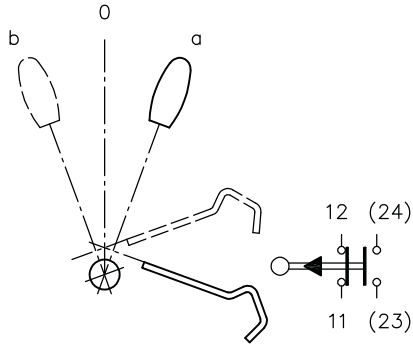

Circuit symbol R, P

Switch is to be adjusted so that the contact bridge 23 - 24 is open in the neutral position and closed in position a.

Neutral position

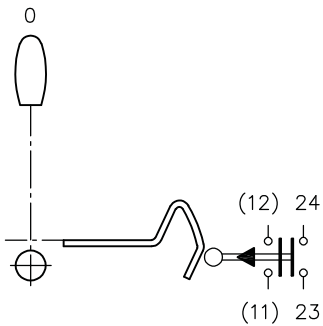

Position a

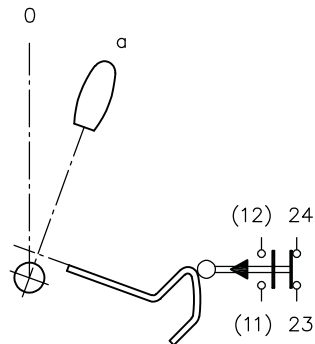

B 4, B 5

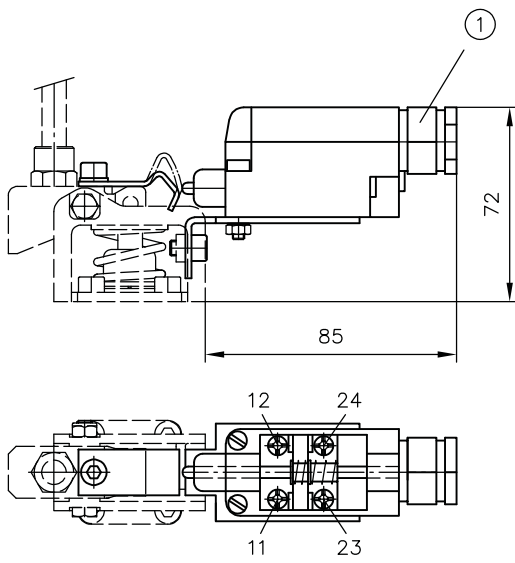

1 Cable fitting

B 81, B 91

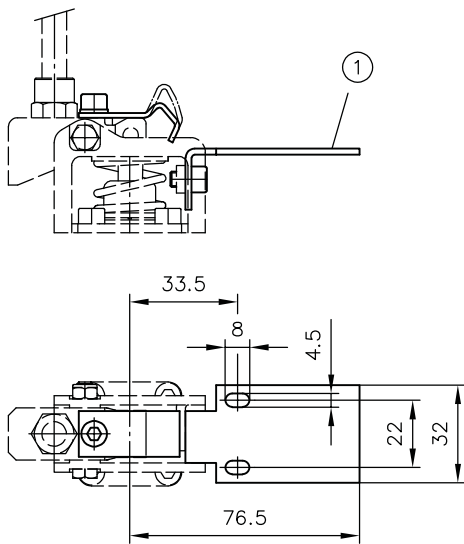

1 Switch retainer

B 6, B 7

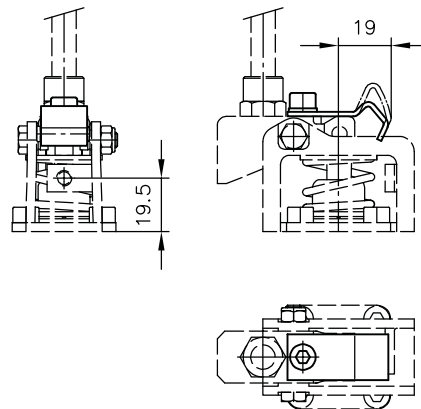

Version B 4 S, B 5 S, B 40, B 50, B 8, B 9

Circuit symbol G, B, D, E, N, A

The switch is pressed in the spool valve neutral position; for circuit symbols N and A it is also pressed in position a.

Neutral position

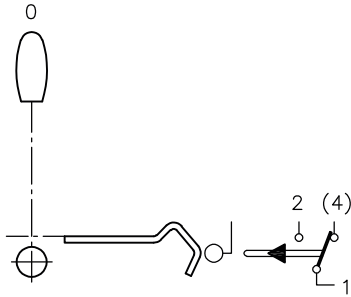

Position a or b

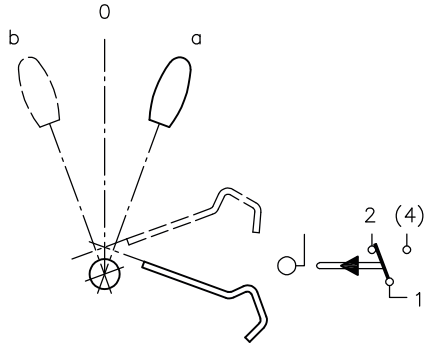

Connection	Colour	B 4 S, B 5 S	B 40, B 50
1	Black	--	--
2	Grey	N/C contact	N/O contact
4	Blue	N/O contact	N/C contact

B 4 S, B 5 S

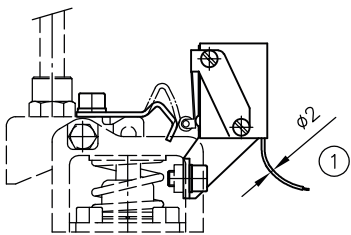

1 Approx. 500 long

B 8, B 9

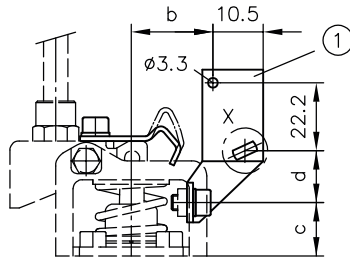

1 Switch retainer

B 40, B 50

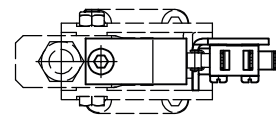
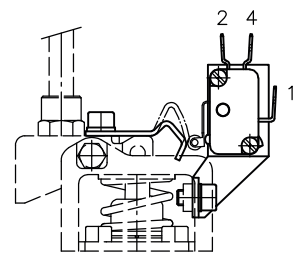

Detail X

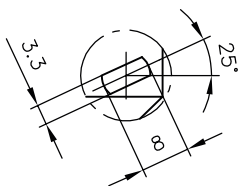

Type	a	b	c	d
DL 1	4,5	18,5	12,5	10
DL 2	6	26	17,5	17

2.2.5 Mounting type

Mounting direction

- Connection block left
- Add-on spool valve connected from left to right

Control lever actuation

- a = spool is pushed into the spool block
- b = spool is pulled into the spool block

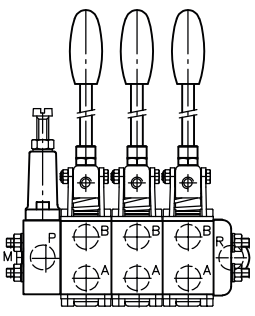
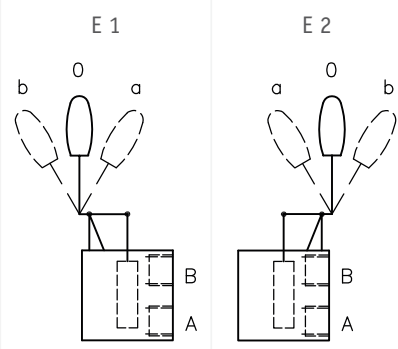
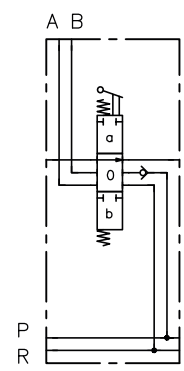
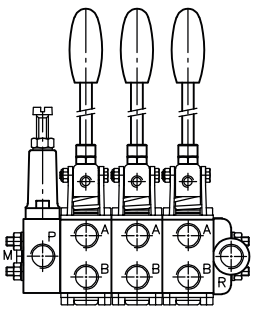
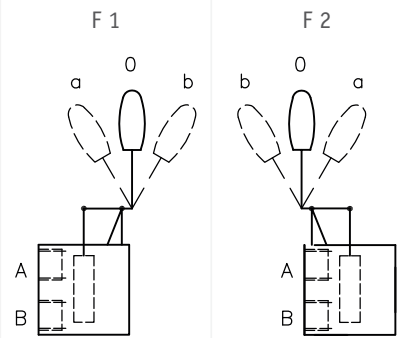
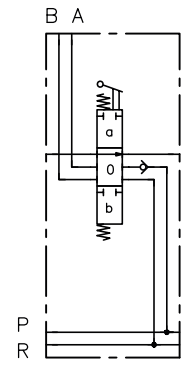
Coding	Description	View	Circuit symbol
E 1 E 2	Ports A, B, R point backwards <ul style="list-style-type: none"> ▪ E 1: Standard version ▪ E 2: Actuation housing turned through 180° 		
F 1 F 2	Ports A, B, R point forwards <ul style="list-style-type: none"> ▪ F 1: Standard version ▪ F 2: Actuation housing turned through 180° Only in conjunction with connection block coding DL 2 (Chapter 2.1.1, "Basic type and size") 		

2.3 End plate

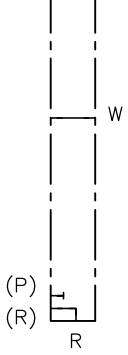
Coding	Description	Circuit symbol
2	End plate with R port for returning the flow rate to the tank. Standard version made of zinc die casting.	 <p>The circuit symbol for end plate 2 is a vertical rectangle with a dashed outline. At the bottom, there is a port labeled 'R'. To the left of the 'R' port, there are two labels: '(P)' above '(R)'. A horizontal line extends from the 'R' port to the right edge of the rectangle.</p>
2 ST	End plate with R port for returning the flow rate to the tank. Version made of steel for use with increased return pressure. Only in conjunction with connection block coding DL 1 (Chapter 2.1.1, "Basic type and size")	
3	End plate made from steel with W port for connecting another manifold	 <p>The circuit symbol for end plate 3 is a vertical rectangle with a dashed outline. At the bottom, there is a port labeled 'R'. To the left of the 'R' port, there are two labels: '(P)' above '(R)'. A horizontal line extends from the 'R' port to the right edge of the rectangle. A port labeled 'W' is located on the right edge of the rectangle, approximately halfway up.</p>

3 Parameters

3.1 General data

Designation	Directional spool valve bank
Design	Spool valve, manually operated
Model	Valve bank
Material	<ul style="list-style-type: none"> ▪ Spool block coding L 1: Steel ▪ Connection block coding DL 1 and DL 2 as well as spool block coding L 2: Steel, nitrided surface ▪ End plate coding 2: Zinc die casting ▪ End plate coding 2 ST and 3: Steel, nitrided surface
Attachment	Mounting thread or tapped holes, see Chapter 4, "Dimensions"
Installation position	Any
Ports/connections	<ul style="list-style-type: none"> ▪ P: Pump ▪ R: Reflux ▪ A, B, H: Consumer ▪ W: Additional, pressure-loadable port
Hydraulic fluid	<p>Hydraulic fluid, according to DIN 51 524 Parts 1 to 3; ISO VG 10 to 68 according to DIN ISO 3448</p> <p>Viscosity range: 4 - 1500 mm²/s</p> <p>Optimal operating range: approx. 10 - 500 mm²/s</p> <p>Also suitable for biologically degradable hydraulic fluids type HEPG (polyalkylene glycol) and HEES (synthetic ester) at operating temperatures up to approx. +70°C.</p>
Cleanliness level	<p>ISO 4406</p> <hr style="width: 20%; margin-left: 0;"/> <p>20/17/14</p>
Temperatures	<p>Environment: approx. -40 to +80 °C, hydraulic fluid: -25 to +80 °C, pay attention to the viscosity range.</p> <p>Start temperature: down to -40°C is permissible (observe start viscosities) as long as the steady-state temperature is at least 20K higher during subsequent operation.</p> <p>Biologically degradable hydraulic fluids: note manufacturer specifications. With consideration for the seal compatibility, not above +70°C.</p>

3.2 Pressure and volumetric flow

Operating pressure	<ul style="list-style-type: none"> ▪ $p_{\max} = 315$ bar (ports P, A, B) ▪ $p_{R \max} = 20$ bar
Flow rate	see Chapter 2.1.1, "Basic type and size"

3.3 Weight

Connection block with pressure-limiting valve	Type			
	DL 1	= 0.3 kg		
	DL 2	= 0.45 kg		
Connection block without pressure-limiting valve	Type			
	DL 1	= 0.4 kg		
	DL 2	= 0.5 kg		
Add-on spool valve with actuation	Type			
	DL 1	= 0.5 kg		
	DL 2	= 0.85 kg		
End plate	Type	Coding		
		2	2 ST	3
	DL 1	= 0.1 kg	= 0.1 kg	= 0.3 kg
	DL 2	= 0.15 kg	--	= 0.4 kg

3.4 Characteristic lines

Viscosity of the hydraulic fluid approx. 60 mm²/s

Circulation pressure P → R

DL 1

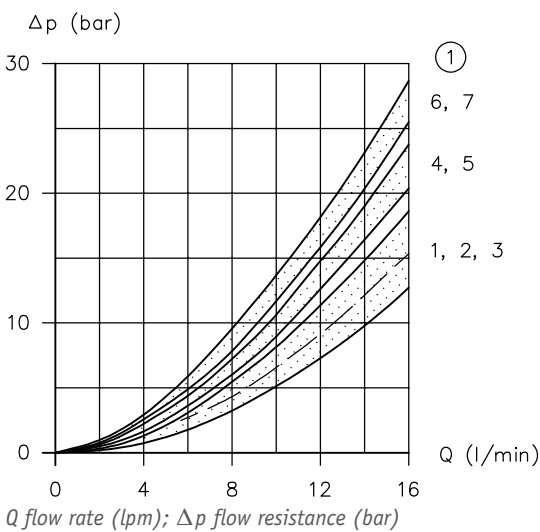

1 Number of spools

DL 2

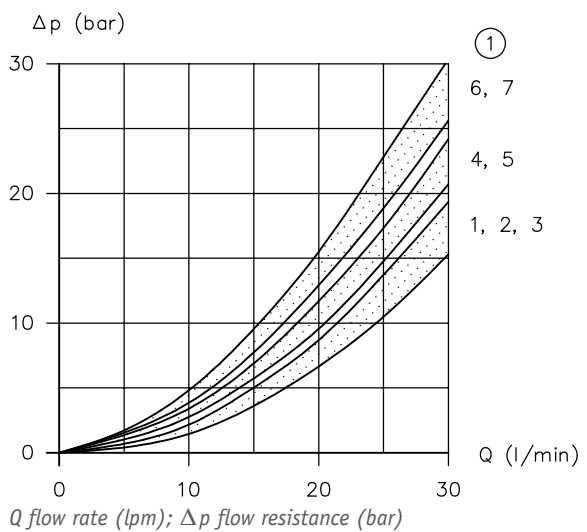

1 Number of spools

Pressure difference P → A/B and A/B → R or P → H and H → R

Circuit symbol G, B, D, E, N, R

DL 1

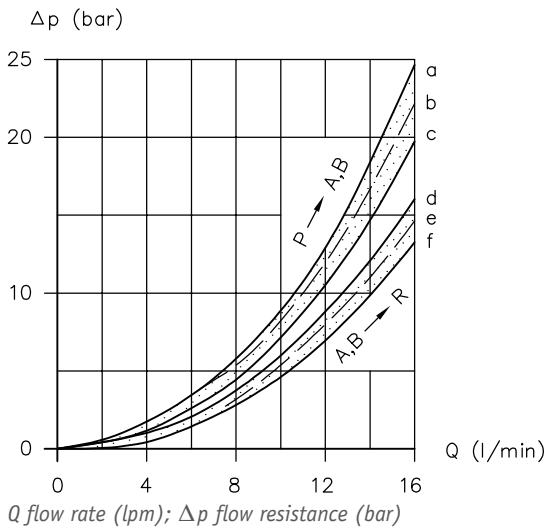

DL 2

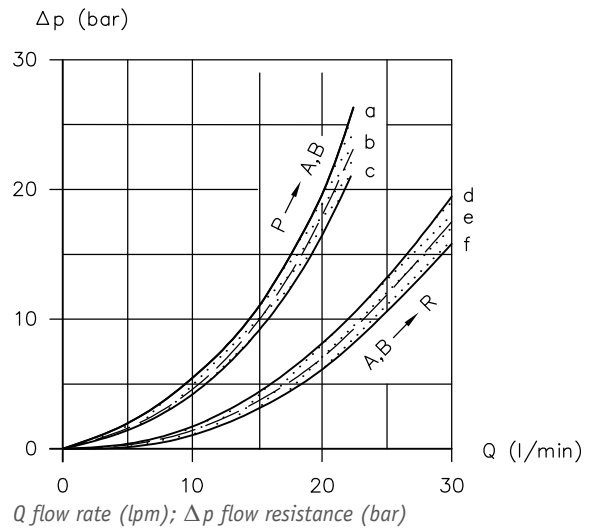

Sequence
Valve sections

Number of valve sections

	Number of valve sections													
	P → A/B							A/B → R						
	1	2	3	4	5	6	7	1	2	3	4	5	6	7
1st	c	c	c	c	c	c	c	f	f	f	e	e	d	d
2nd		c	c	c	c	c	c		f	f	f	e	e	d
3rd			b	b	b	b	b			f	f	f	e	e
4th				b	b	b	b				f	f	f	e
5th					b	b	b					f	f	f
6th						a	a						f	f
7th							a							f

Circuit symbol A, P

DL 1

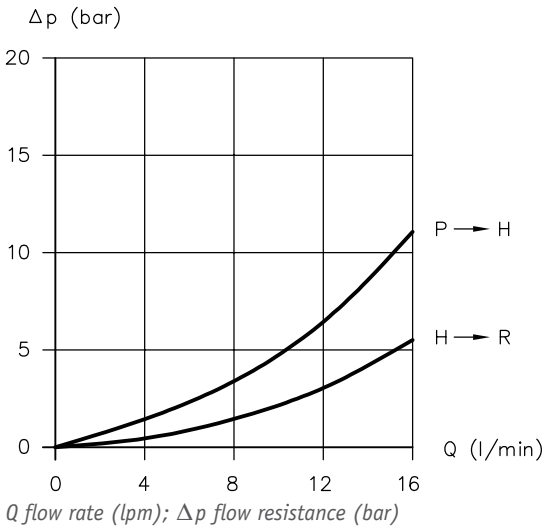

DL 2

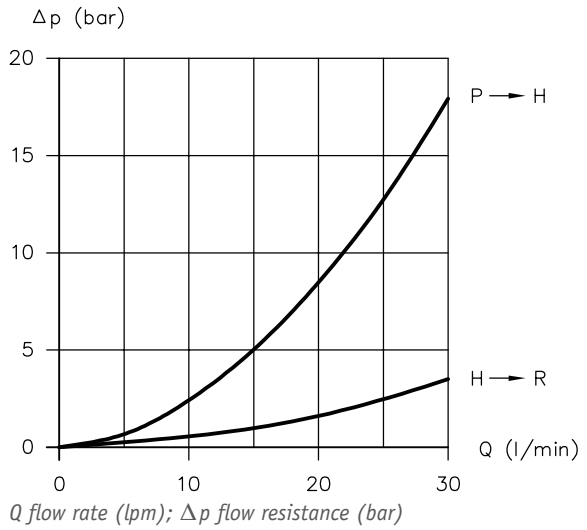

Flow resistance per control edge:

The characteristic lines always apply to the specified flow direction. For 4/3 or 4/2-way directional spool valves, the overall resistance Δp , measured at input P, is composed of the inflow side element Δp_{in} and the outflow side element Δp_{out} . Here it is to be noted that on consumers with a cylinder area ratio not equal to one φ (differential cylinders) the return flow Q_{out} may be less than or greater than the inflow Q_{in} , depending on the direction of movement!

$$\Delta p = \Delta p_{in} + \frac{\Delta p_{out}}{\varphi}$$

$$Q_{out} = \frac{Q_{in}}{\varphi}$$

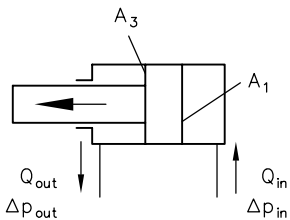

$$\Delta p = \Delta p_{in} + \Delta p_{out} \cdot \varphi$$

$$Q_{out} = Q_{in} \cdot \varphi$$

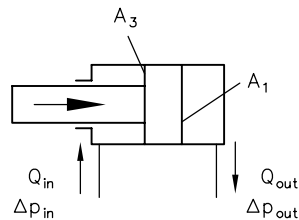

$$\varphi = \frac{A_1}{A_3}$$

Δp = Overall resistance

Δp_{in} = Pressure loss inflow side

Δp_{out} = Pressure loss outlet side

Q_{in} = Flow rate inflow side

Q_{out} = Flow rate outlet side

φ = Cylinder area ratio

A_1 = Area piston side

A_3 = Area rod side

3.5 Electrical data Contact switch

Coding B 4, B 5

Protection class	IP 67
Mechanical service life	30 x 10 ⁶ switching cycles
Switching frequency	3600 switches/h
Switching of small loads	Min. 24 V DC / 10 mA
Thermal nominal current	10 A

Coding B 4 S, B 5 S

Protection class	IP 67
Mechanical service life	10 ⁶ switches
Function	Changeover switch
Resistance load at 15 – 30 V DC	3 A

Coding B 40, B 50

Protection class	IP 40
Mechanical service life	2.5 x 10 ⁵ to 50 x 10 ⁶ switches
Function	Changeover switch

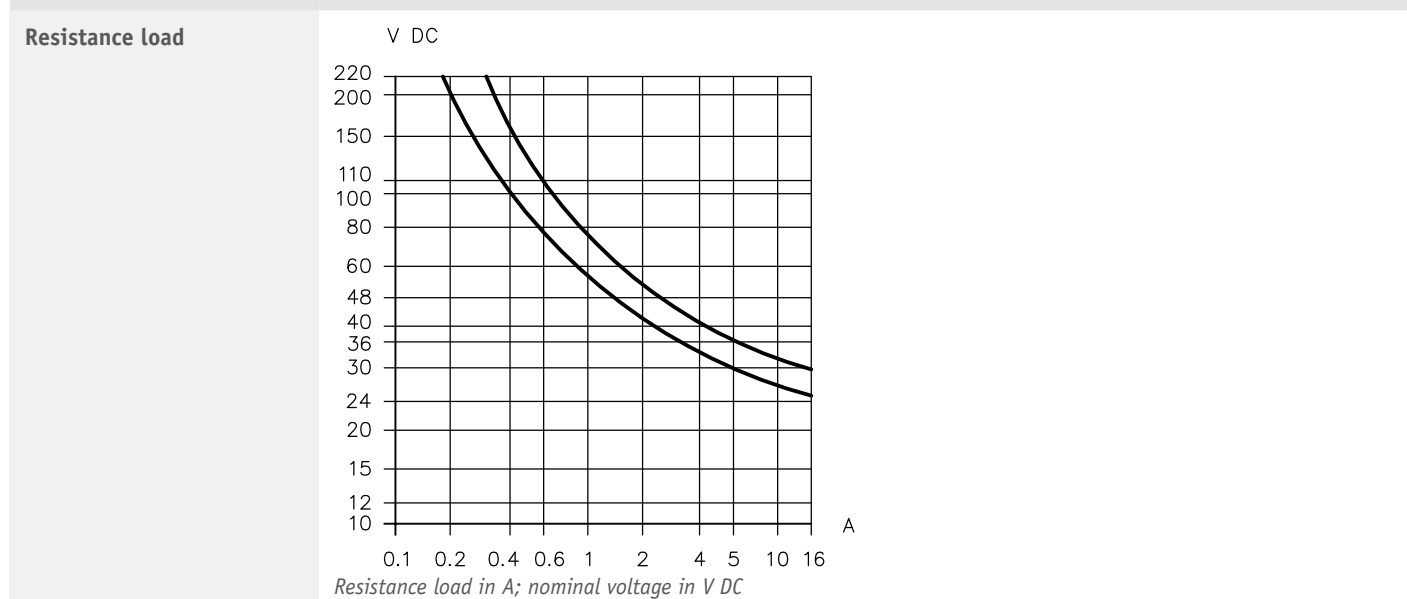

4 Dimensions

All dimensions in mm, subject to change.

4.1 Connection block

DL 1

Connection block without pressure-limiting valve

DL 15

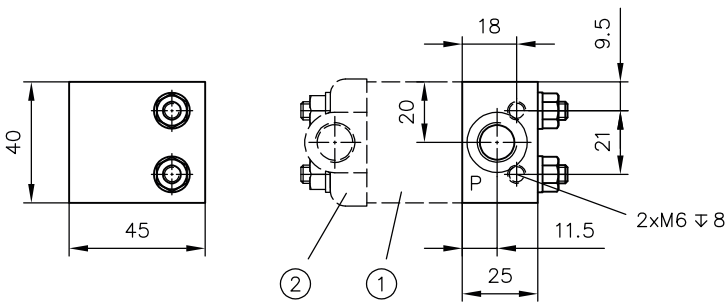

- 1 Valve section
- 2 End plate

Connection block with pressure-limiting valve

DL 11

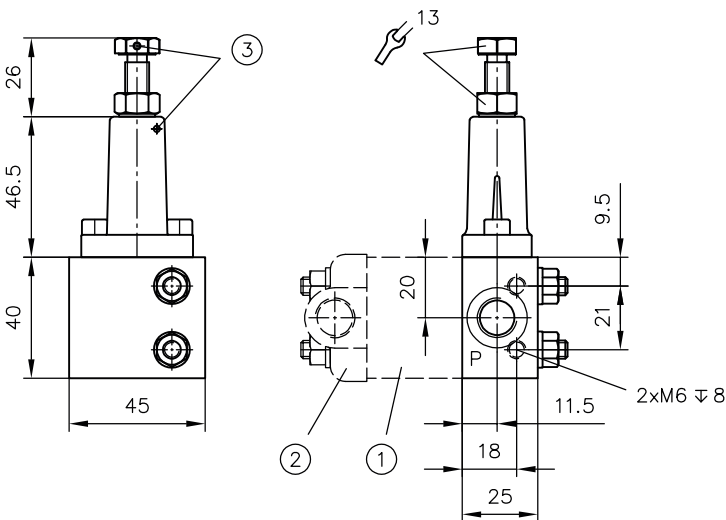

- 1 Valve section
- 2 End plate
- 3 Sealing option

Ports (ISO 228-1)

P	G 1/4
---	-------

DL 2

Connection block without pressure-limiting valve

DL 25

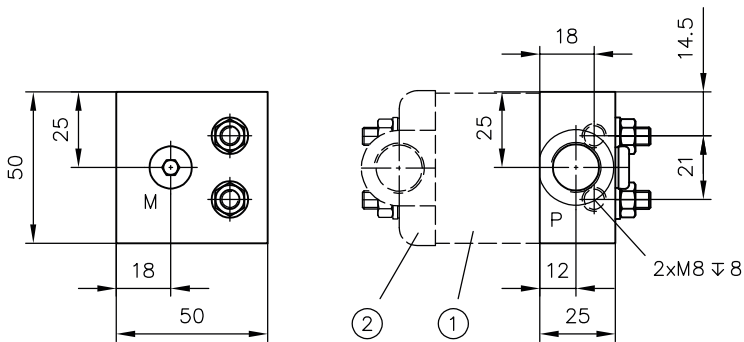

- 1 Valve section
- 2 End plate

Connection block with pressure-limiting valve

DL 21

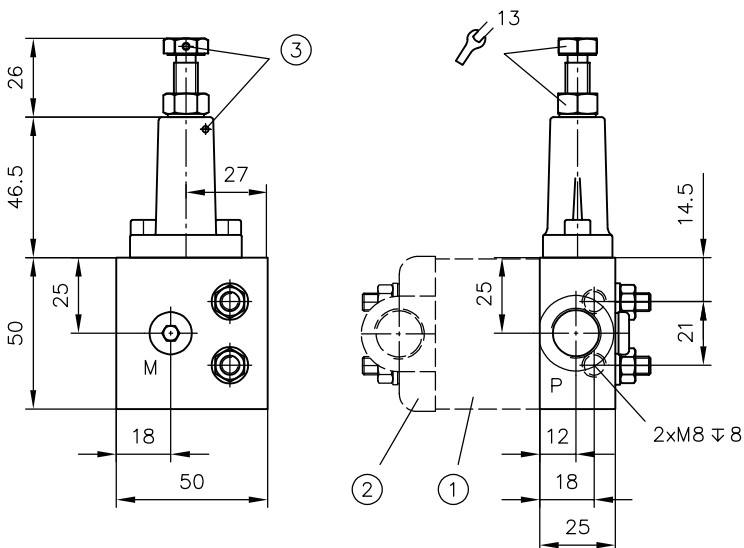

- 1 Valve section
- 2 End plate
- 3 Sealing option

Ports (ISO 228-1)

P	G 3/8
---	-------

4.2 Valve section

DL 1

Circuit symbol **G, B, D, E, N, R**

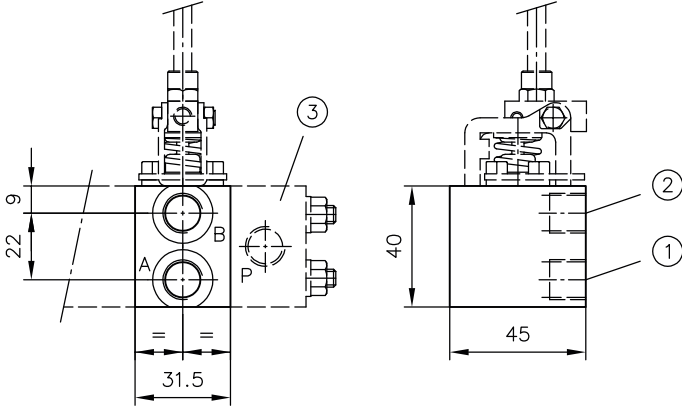

- 1 Circuit symbol **N**: Port A not applicable for all mounting types
- 2 Circuit symbol **R**: Port B not applicable for all mounting types
- 3 Connection block

Ports (ISO 228-1)

A, B	G 1/4
------	-------

DL 2

Circuit symbol **G, B, D, E, N, R**

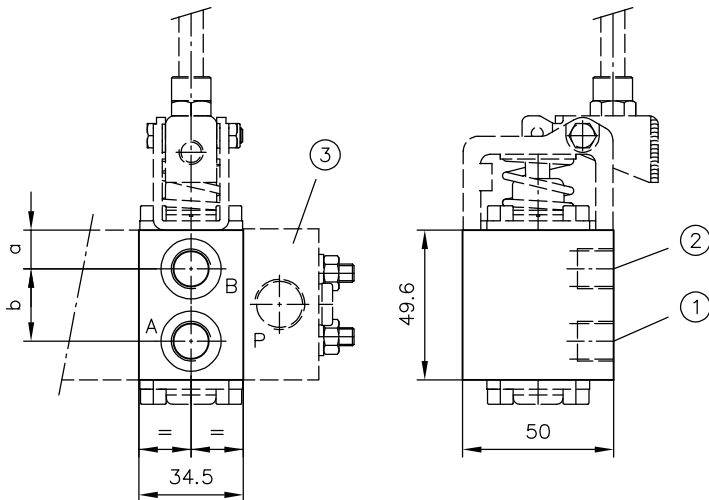

- 1 Circuit symbol **N**:
 - Port A not applicable for mounting types E 1 and E 2
 - Port B not applicable for mounting types F 1 and F 2
- 2 Circuit symbol **R**: Port B not applicable for all mounting types
- 3 Connection block

Coding Consumer port	a	b	Ports (ISO 228-1)
			A, B
1	12,8	24	G 1/4
2	10,8	28	G 3/8

Circuit symbol **A**

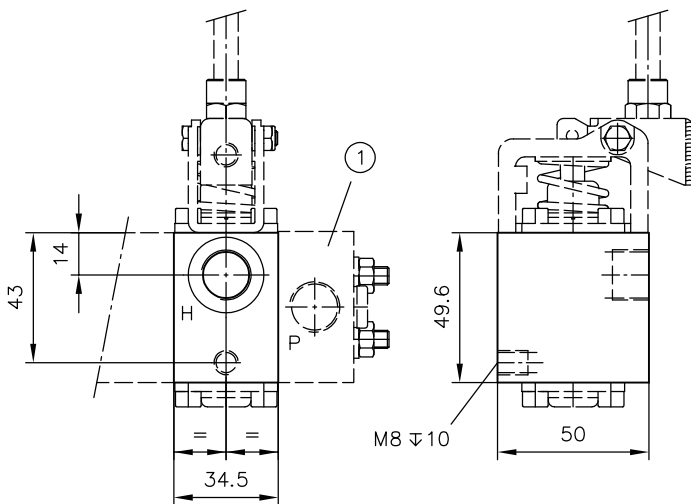

1 Connection block

Circuit symbol **P**

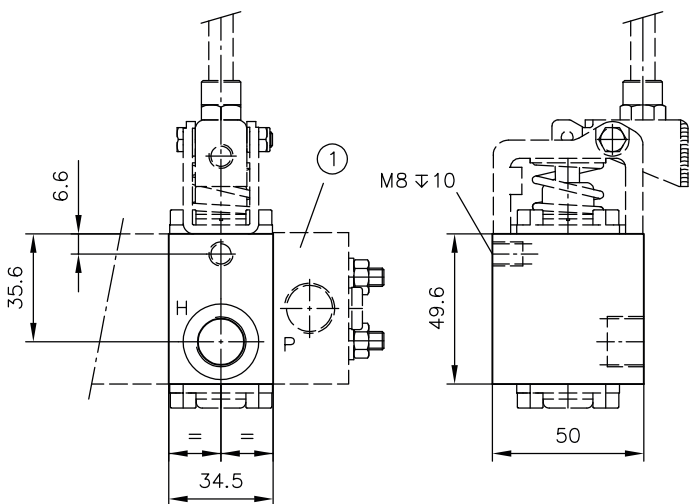

1 Connection block

Coding
Consumer port

Ports (ISO 228-1)

2

H

G 3/8

4.3 Actuation

4.3.1 Manual actuation with spring return

DL 1

Coding **B**

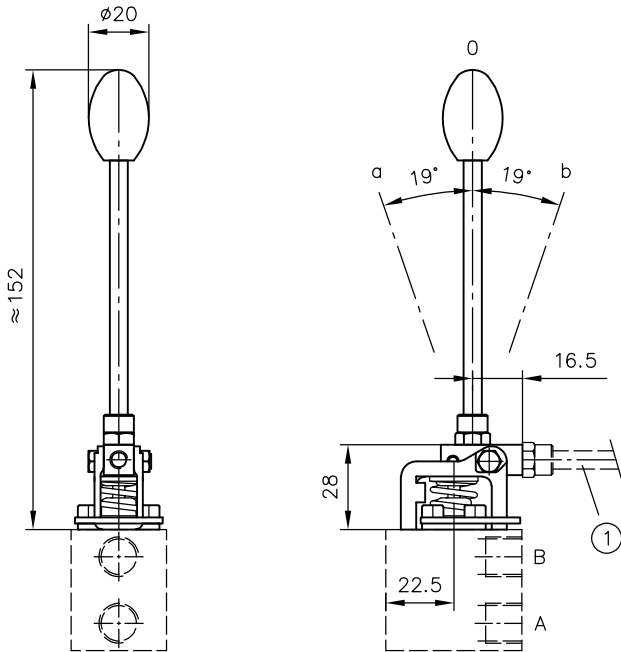

1 Hand lever can be attached here

DL 2

Coding B

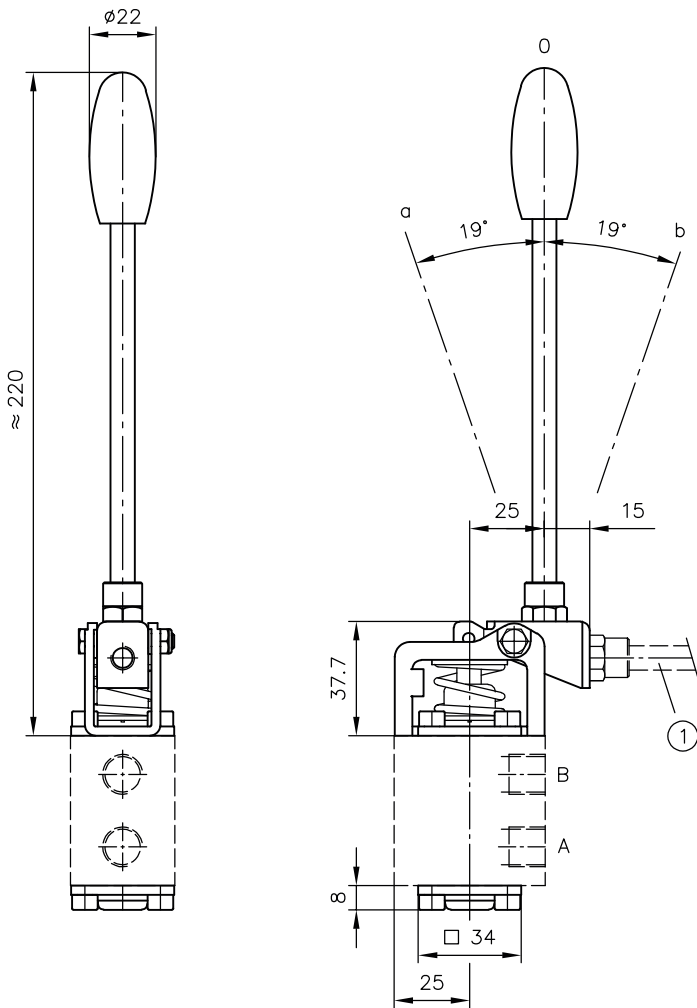

1 Hand lever can be attached here

4.3.2 Manual actuation with detent

DL 1

Coding C, D

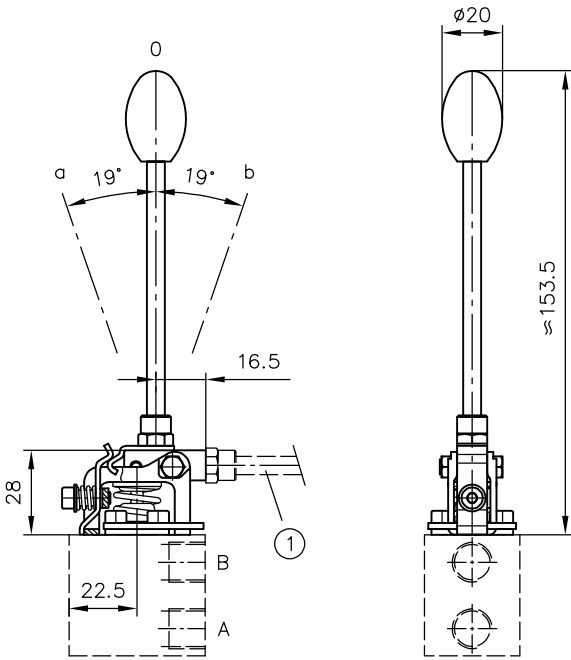

1 Hand lever can be attached here

DL 2

Coding C, D

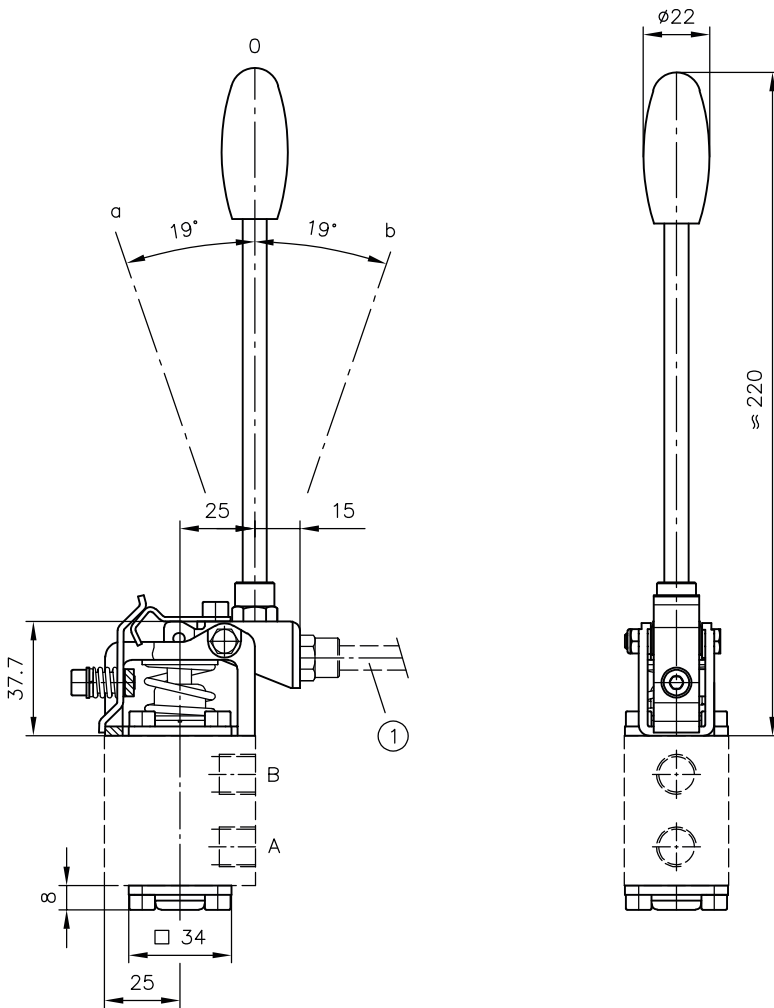

1 Hand lever can be attached here

4.4 Mounting type

DL 1

Coding E 1, E 2

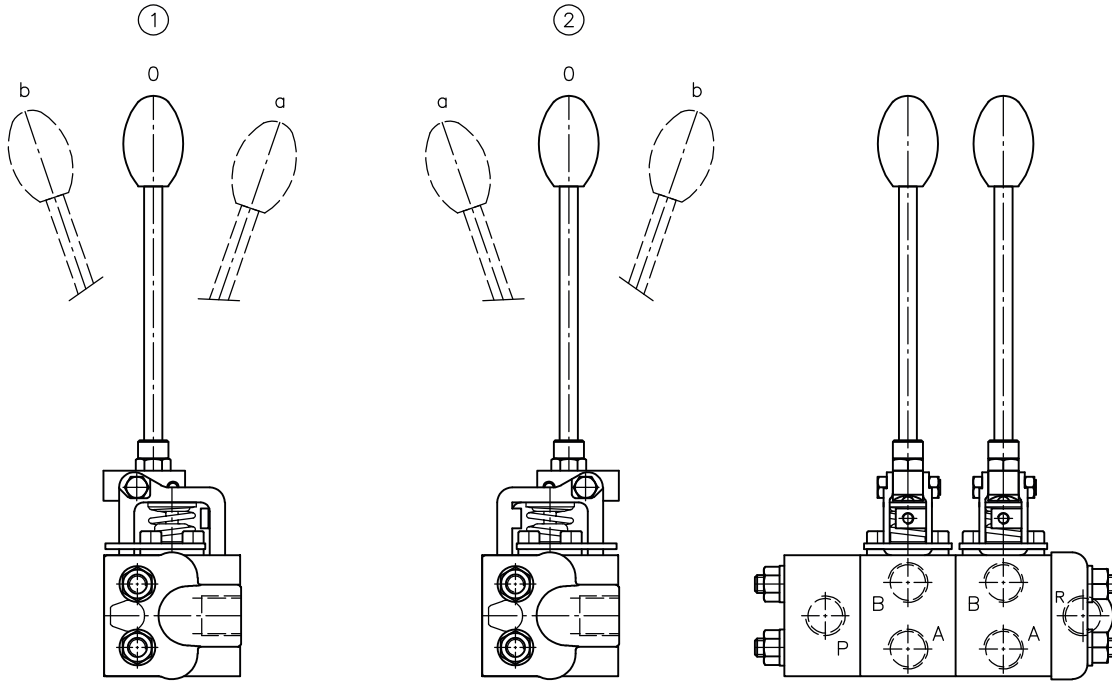

- 1 Mounting type E 1
- 2 Mounting type E 2: Actuation housing turned through 180°

DL 2

Coding E 1, E 2

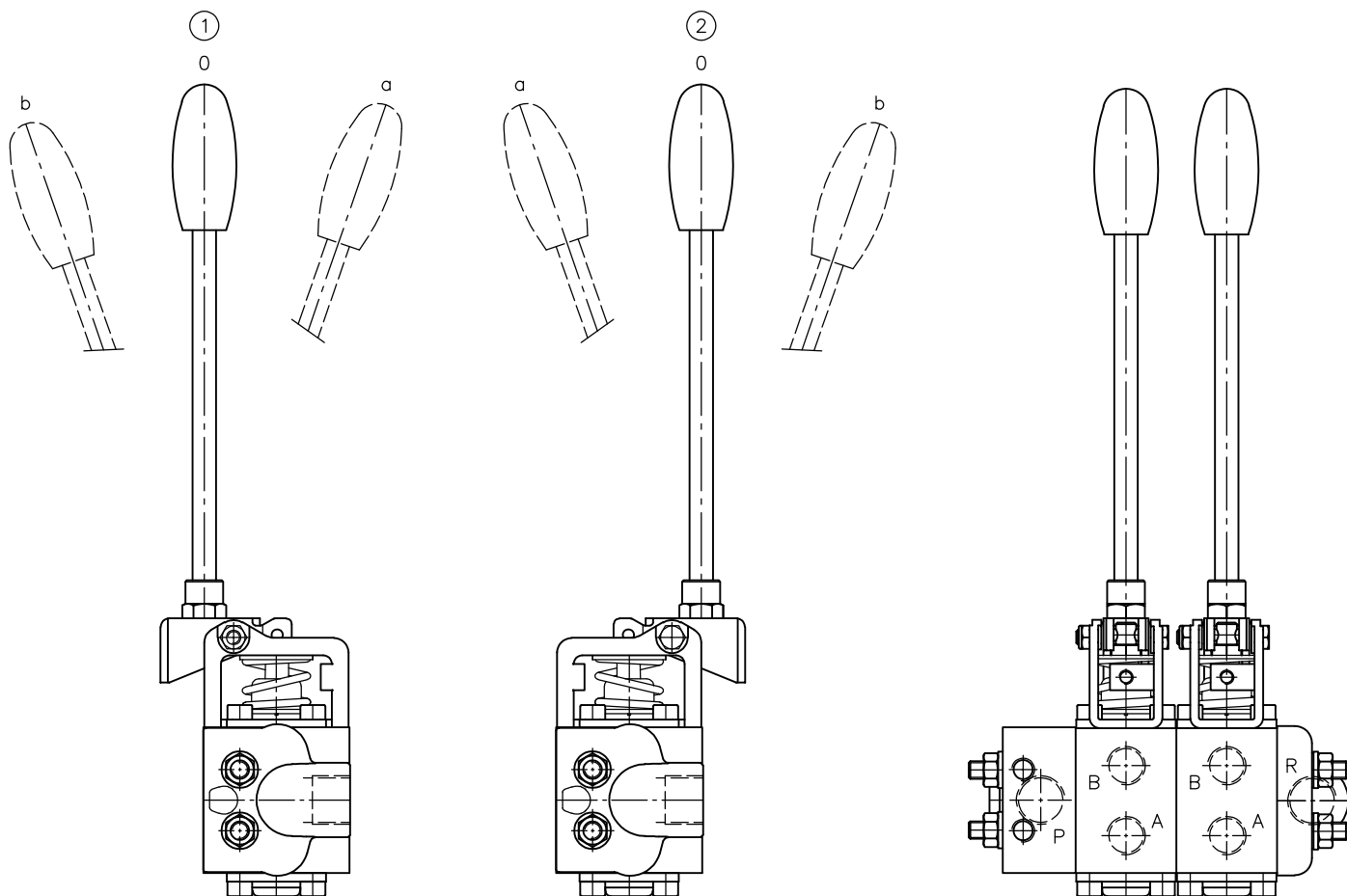

- 1 Mounting type E 1
- 2 Mounting type E 2: Actuation housing turned through 180°

Coding **F 1, F 2**

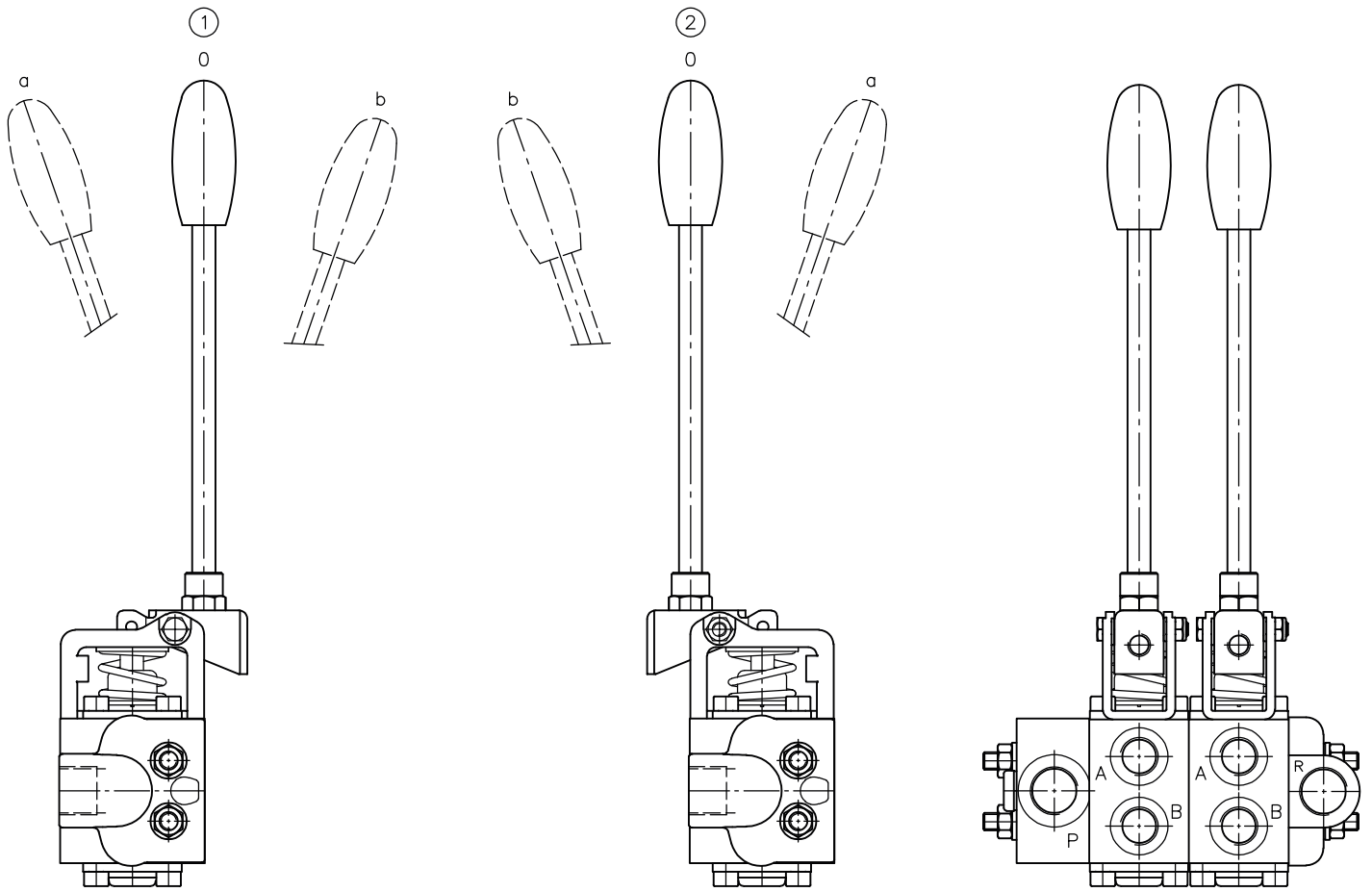

- 1 Mounting type F 1
- 2 Mounting type F 2: Actuation housing turned through 180°

4.5 End plate

DL 1

Coding 2

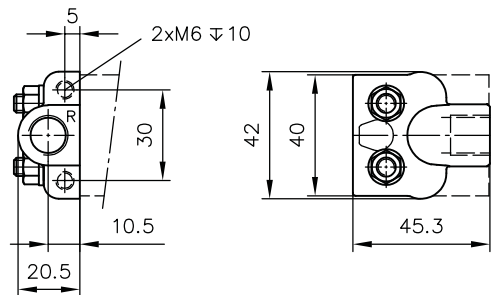

Coding 2 ST

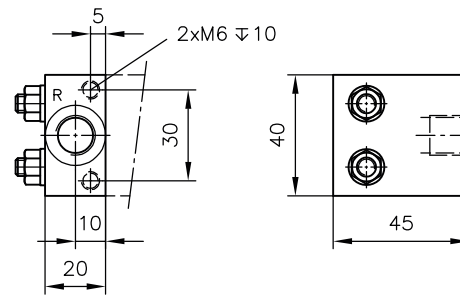

Coding 3

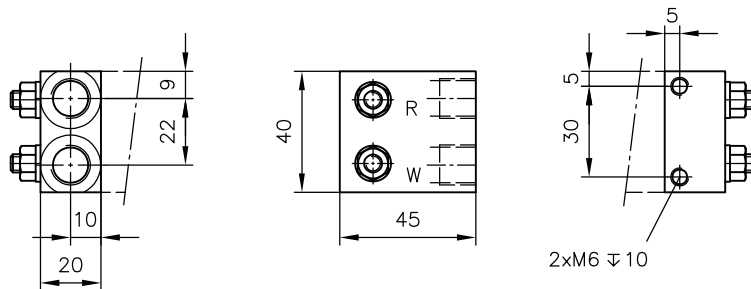

DL 2

Coding 2

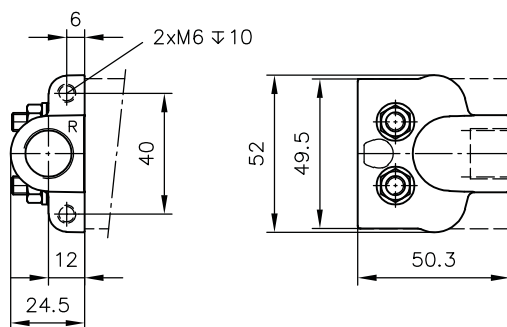

Coding 3

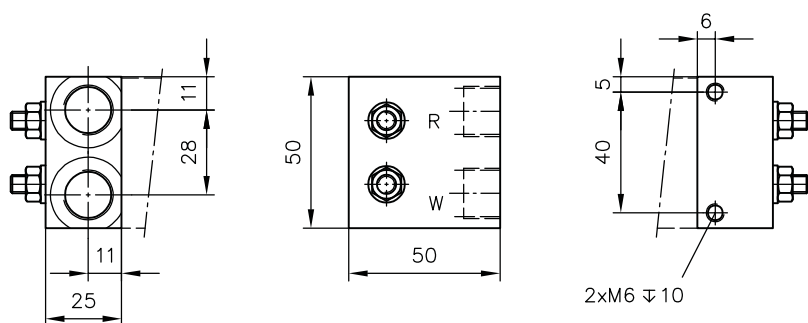

Observe the document B 5488 "General operating instructions for assembly, commissioning, and maintenance."

5.1 Intended use

This product is intended exclusively for hydraulic applications (fluid technology).

The user must observe the safety measures and warnings in this document.

Essential requirements for the product to function correctly and safely:

- ▶ All information in this documentation must be observed. This applies in particular to all safety measures and warnings.
- ▶ The product must only be assembled and put into operation by specialist personnel.
- ▶ The product must only be operated within the specified technical parameters described in detail in this document.
- ▶ All components must be suitable for the operating conditions when using an assembly.
- ▶ The operating instructions for the components, assemblies and the specific complete system must also always be observed.

If the product can no longer be operated safely:

1. Remove the product from operation and mark it accordingly.
 - ✓ It is then not permitted to continue using or operating the product.

5.2 Assembly information

The product must only be installed in the complete system with standard and compliant connection components (screw fittings, hoses, pipes, fixtures etc.).

The product must be shut down correctly prior to disassembly (in particular in combination with hydraulic accumulators).

DANGER

Sudden movement of the hydraulic drives when disassembled incorrectly

Risk of serious injury or death

- ▶ Depressurise the hydraulic system.
- ▶ Perform safety measures in preparation for maintenance.

5.3 Operating instructions

Observe product configuration and pressure/flow rate.

The statements and technical parameters in this document must be strictly observed.

The instructions for the complete technical system must also always be followed.

NOTICE

- ▶ Read the documentation carefully before usage.
- ▶ The documentation must be accessible to the operating and maintenance staff at all times.
- ▶ Keep documentation up to date after every addition or update.

CAUTION

Overloading components due to incorrect pressure settings.

Risk of minor injury.

- Pay attention to the maximum operating pressure of the pump, valves and fittings.
- Always monitor the pressure gauge when setting and changing the pressure.

Purity and filtering of the hydraulic fluid

Fine contamination can significantly impair the function of the product. Contamination can cause irreparable damage.

Examples of fine contamination include:

- Swarf
- Rubber particles from hoses and seals
- Dirt due to assembly and maintenance
- Mechanical debris
- Chemical ageing of the hydraulic fluid

! NOTICE

New hydraulic fluid from the manufacturer may not have the required purity.

Damage to the product is possible.

- ▶ Filter new hydraulic fluid to a high quality when filling.
- ▶ Do not mix hydraulic fluids. Always use hydraulic fluid that is from the same manufacturer, of the same type, and with the same viscosity properties.

For smooth operation, pay attention to the cleanliness level of the hydraulic fluid (cleanliness level [see Chapter 3, "Parameters"](#)).

Additionally applicable document: [D 5488/1](#) Oil recommendations

5.4 Maintenance information

Check regularly (at least once a year) by visual inspection whether the hydraulic connections are damaged. If external leakages are found, shut down and repair the system.

Clean the surface of the device regularly (at least once a year) (dust deposits and dirt).

References

Additional versions

- Proportional directional spool valves types PSL, PSV size 2: D 7700-2
- Proportional directional spool valves types PSL/PSV/PSM, size 3: D 7700-3
- Proportional directional spool valve, type PSL, PSM and PSV size 5: D 7700-5
- Proportional directional spool valve type EDL: D 8086
- Directional spool valve banks type CWS: D 7951 CWS
- Directional spool valve type CWL: D 7953 CWL

