

# Air-driven hydraulic pump / hydraulic power pack type LP

## Product documentation



For permanent, short-period and intermittent operation and for continuous run with intermittent load (S1, S2, S3, S6)

Operating pressure $p_{\max \text{ hydr.}}$ :	700 bar
Operating pressure $p_{\max \text{ pneum.}}$ :	10 bar
Displacement volume $V_{\max \text{ geom.}}$ :	29 cm <sup>3</sup> /double stroke
Delivery flow rate $Q_{\max \text{ hydr.}}$ :	12 l/min
Tank volume $V_{\max \text{ tank}}$ :	34 l

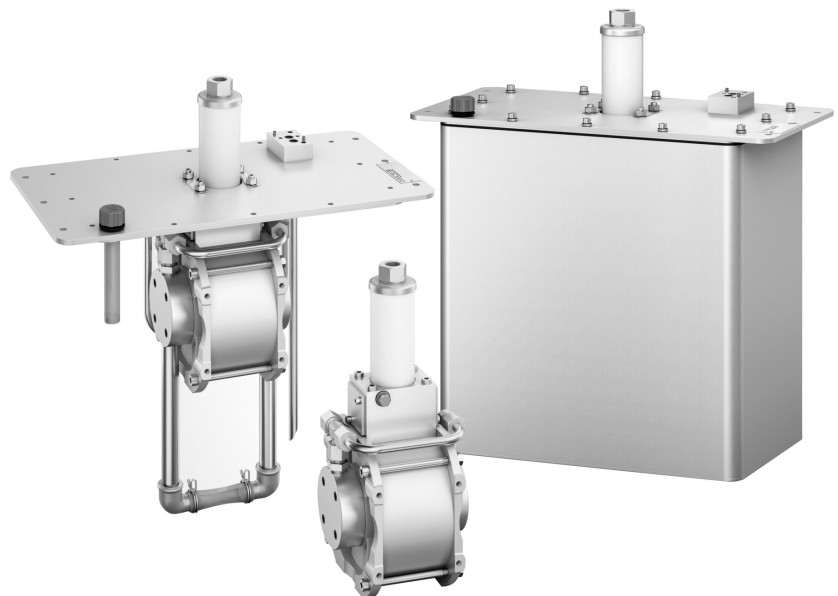

© by HAWE Hydraulik SE.

The reproduction and distribution of this document, as well as the use and communication of its contents to others without explicit authorization, is prohibited.

Offenders will be held liable for the payment of damages.

All rights reserved in the event of patent or utility model applications.

Brand names, product names and trademarks are not specifically indicated. In particular with regard to registered and protected names and trademarks, usage is subject to legal provisions.

HAWE Hydraulik respects these legal provisions in all cases.

HAWE Hydraulik cannot provide individual guarantees that the stated circuits or procedures (including in part) are not subject to the intellectual property rights of third parties.

Printing date / document generated on: 2024-09-27

## Table of Contents

<b>1</b>	<b>Overview of air-driven hydraulic pump / hydraulic power pack type LP.....</b>	<b>4</b>
1.1	Air-side seals made from PTFE.....	4
<b>2</b>	<b>Available versions.....</b>	<b>5</b>
2.1	Basic type, size and plunger pistons.....	6
2.2	Pump version.....	7
2.3	Pipe module.....	8
2.4	Intake module.....	9
2.5	Tank and cover plate.....	9
2.6	Level switch.....	10
2.7	Level gauge.....	10
2.8	Geometry.....	10
2.9	Pressure.....	11
2.10	Approval.....	11
<b>3</b>	<b>Parameters.....</b>	<b>12</b>
3.1	General data.....	12
3.2	Pressure and volumetric flow.....	13
3.3	Weight.....	14
3.4	Characteristic lines.....	15
3.4.1	Running noise.....	19
3.5	Additional options.....	21
3.5.1	Level switch.....	21
<b>4</b>	<b>Dimensions.....</b>	<b>22</b>
4.1	Hydraulic pump.....	22
4.1.1	LP 80.....	22
4.1.2	LP 125.....	24
4.1.3	LP 160.....	26
4.2	Hydraulic power pack.....	28
4.2.1	B4, D4.....	28
4.2.2	B10, D10.....	29
4.2.3	B25, D25.....	30
4.3	Geometry.....	31
4.4	Hydraulic connections.....	32
<b>5</b>	<b>Installation, operation and maintenance information.....</b>	<b>33</b>
<b>6</b>	<b>Other information.....</b>	<b>34</b>
6.1	Maintenance unit.....	34
6.2	Long running times.....	34
6.3	Connection blocks.....	35
6.4	Directional valve banks.....	36

# 1 Overview of air-driven hydraulic pump / hydraulic power pack type LP

Air-driven hydraulic pumps are pneumatically driven, reciprocally acting plunger pumps. They operate as pneumatic pressure amplifiers with oscillating movement and automatic stroke reversal control.

In the case of the air-driven hydraulic pump type LP, the flow rate depends on the set air pressure and the currently effective hydraulic counter-pressure. It can drop away until the pump comes to a standstill. The pump starts up again independently once the hydraulic consumer pressure falls (maintaining pressure) or the pneumatic pressure increases further.

The hydraulic pump type LP is available as a single pump, in the cover plate version or as a hydraulic power pack with different tank sizes. Compatible, ready-for-connection, complete solutions can be assembled easily using a wide range of connection blocks and the valve banks that can be combined with them. The cover plate version is intended for use of tanks provided by the customer.

## Features and advantages

- High operating pressures
- Suitable for use in potentially explosive areas
- Energy supplied by means of compressed air
- Start-stop can be implemented via pump

## Intended applications

- Machine tools
- Testing and laboratory equipment
- Hydraulic tools
- Hydraulic fixtures
- Hoisting equipment

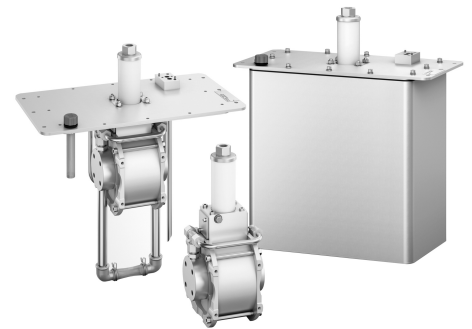

*Air-driven hydraulic pump / hydraulic power pack type LP*

## 1.1 Air-side seals made from PTFE

Air-side seals are designed with PTFE cuffs.

### Features and advantages

- Low friction
- High oil delivery flow
- Excellent temperature resistance
- Low seal wear

## 2 Available versions

### Circuit symbol

#### Hydraulic pump

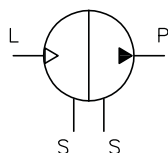

#### Hydraulic power pack

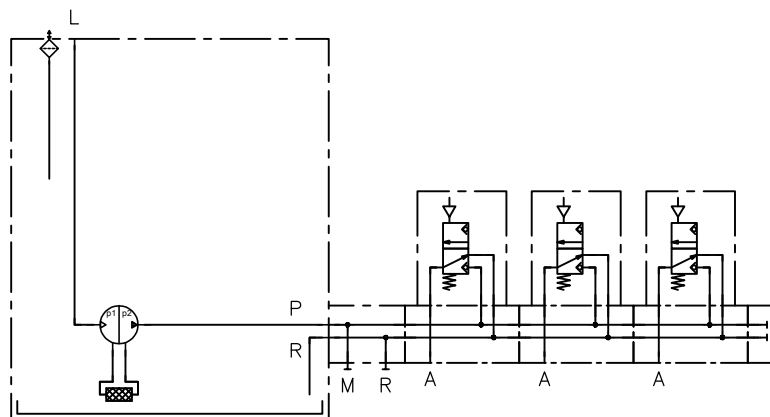

The valves are examples, optional.

### Ordering examples

Pump:	LP 80-10	/P	-R8	-X	-NBR	-P1	-X	-X	-EX	
Hydraulic power pack (tank):	LP 80-10	/B4	-D	-K1	-NBR	-X	-X	-X	-N	-AB 1
Hydraulic power pack (cover plate):	LP 125-12	/D4	-X	-S250	-NBR	-X	-X	-X	-N	-C 5

6.3 "Connection blocks"

2.10 "Approval"

**Additional options** none (series)

2.9 "Pressure"

2.8 "Geometry"

**Seal** NBR (hydraulic side)

- Pump: 2.4 "Intake module"
- Cover plate version: 2.4 "Intake module"
- Tank version: 2.7 "Level gauge"

- Pump: 2.3 "Pipe module"
- Hydraulic power pack: 2.6 "Level switch"

- Pump: 2.2 "Pump version"
- Hydraulic power pack: 2.5 "Tank and cover plate"

2.1 "Basic type, size and plunger pistons"

## 2.1 Basic type, size and plunger pistons

Type Piston Ø (air side)	Plunger Ø (hydraulics side)	Maximum permissi- ble pressure (bar)	Corresponding air pressure (bar)	Pressure ratio	Geometric displacement volume per double stroke	
					Hydraulics side V <sub>hydr.</sub> (cm <sup>3</sup> )	Air side V <sub>L</sub> (cm <sup>3</sup> )
LP 80	8	700 (500) <sup>1)</sup>	7.5 (5.3)	1 : 99	1.5	152 – V <sub>hydr.</sub>
	10	600 (500) <sup>1)</sup>	10 (8.5)	1 : 63	2.4	
	12	410	10	1 : 43	3.4	
	16	225	10	1 : 24	6.1	
LP 125	8 <sup>2)</sup>	700	3.0	1 : 243	2.1	503 – V <sub>hydr.</sub>
	10 <sup>2)</sup>		4.6	1 : 155	3.2	
	12		6.7	1 : 108	4.6	
	16	585	10	1 : 60	8.2	
	18	460		1 : 47	10.4	
	20	370		1 : 38	12.9	
	25	230		1 : 24	20.1	
	30	150		1 : 16	29.0	
LP 160	8 <sup>2)</sup>	700	1.9	1 : 399	2	812 – V <sub>hydr.</sub>
	10 <sup>2)</sup>		2.9	1 : 255	3.2	
	12		4.1	1 : 177	4.6	
	16		7.3	1 : 99	8.1	
	18	620	10	1 : 78	10.3	
	20	620		1 : 63	12.7	
	25	390		1 : 40	18.8	
	30	265		1 : 27	28.6	

1) Lower pressure in case of operation as a single pump (with piping) or as a pump cover plate without tank. For operation with a higher pressure, the following applies: A tank provided by the customer with a wall thickness  $\geq 1.5$  mm must be implemented or operation of the single pump WITHOUT piping.

2) Higher pressures on request, only for variant without pipe module with coding X (= self-piping), see Chapter 2.3, "Pipe module".

### ! NOTICE

For self-piping: Make sure that the intended fittings and pipes can withstand the necessary pressure!

## 2.2 Pump version

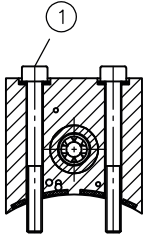
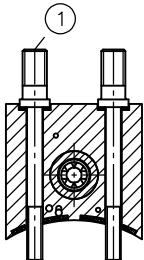
Coding	Description	View
<b>Single pump</b>		
P	Single pump	 <p>1 Cylinder screw</p> <ul style="list-style-type: none"> <li>■ <b>LP 80:</b> Cylinder screw ISO 4762-M5x50-12.9-Geomet 321A</li> <li>■ <b>LP 125:</b> Cylinder screw ISO 4762-M6x70-8.8-A2K</li> <li>■ <b>LP 160:</b> Cylinder screw ISO 4762-M6x80-8.8-A2K</li> </ul>
A	Single pump for cover plate / tank mounting	 <p>1 Grub screw (M8, hex socket AF 4)</p>
<b>Hydraulic power pack</b>		
D	Cover plate version	see Chapter 2.5, "Tank and cover plate"
B	Tank version	

**NOTICE**

Pump version P or A can be converted by replacing the screws.

## 2.3 Pipe module

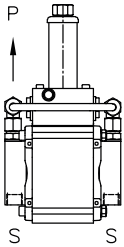
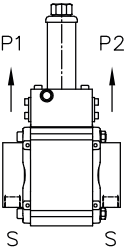
Coding	Description	View
R8 R10	with piping <ul style="list-style-type: none"> <li>08S</li> <li>10S</li> </ul>	 <p>Consolidated to one output P</p>
X	for self-piping	 <p>Individual outputs P1 and P2 for self-piping</p>

### **i** INFORMATION

- LP 80: only R8 possible
- LP 125 and LP 160:
  - R10 = series
  - R8 = optional for the pistons -8 ... -16, reduced pressure  $p_{max} = 530$  bar, downwards compatible with LP pump according to old documentation D 7280 (2000).



## 2.4 Intake module

### **i** INFORMATION

The intake module is only listed in the order code with the version with cover plate or single pump.  
With the tank version, the relevant appropriate intake module is installed and not also listed in the order code.

Coding	For type	Suitable for maximum clear tank height (mm)		Tank version
		H1 = depth (height) of intake module	H1 + H = total height of pump without silencer	
X	no intake module (retrofitable)			
S35	LP 80	max. 35	160	
S60		max. 60	185	
S100		max. 100	225	LP 80..B4
S200		max. 200	325	
S65	LP 125	max. 65	max. 225 *	
S75		max. 75	max. 235 *	LP 125..B4
S165		max. 165	max. 325 *	LP 125..B10
S250		max. 250	max. 410 *	LP 125..B25
S85	LP 160	max. 85	max. 270 *	
S140		max. 140	max. 325 *	LP 160..B10
S220		max. 220	max. 405 *	LP 160..B25

\* The total height H + H1 refers to the configuration with the relevant largest plungerØ see Chapter 2.1, "Basic type, size and plunger pistons"

## 2.5 Tank and cover plate

Coding		Fill volume V <sub>max tank</sub> (l) *	Usable volume V <sub>use</sub> (l) *	suitable for combining with basic pump		
Tank	Cover plate			LP 80	LP 125	LP 160
B4	D4	7	5 (4.7)	●		
		5.8	4 (3.8)		●	
B10	D10	16.6	13.5 (13.3)		●	
		13.5	11.5 (11.4)			●
B25	D25	34	29 (22)		●	
		33	28 (21)			●

\* only applies to the tank version.

### **i** INFORMATION

The values in brackets specify the approximate volume available for removal at which the optional level switch makes contact.

## 2.6 Level switch

Coding	Description	for tank for cover plate	Circuit symbol
X	without additional equipment	B4, B10, B25 D4, D10, D25	-
D	Level switch, N/C contact	B4, B10, B25 D4, D10	
S	Level switch, N/O contact	B4, B10, B25 D4, D10	

## 2.7 Level gauge

Only for tank version.

Coding	Description	for tank	Circuit symbol
X	without additional equipment	B4, B10, B25	-
K1	Level gauge position 1	B4	
K2	Level gauge position 2	B4, B10, B25	
K3	Level gauge position 3	B4	
KK2	2x level gauge (round), position 2	B4	

### **i** INFORMATION

Mounting positions 1, 2, 3, see Chapter 4.2, "Hydraulic power pack"

## 2.8 Geometry

Coding	Designation	LP 80	LP 125	LP 160
X	(series)	●	●	●
D1	Cover plate variant 1, only for D4 (B4), with additional oil inlet with filler sieve see Chapter 4.2.1, "B4, D4"		●	
P1	Location of pressure port and suction port: Rotated 90° clockwise see Chapter 4.3, "Geometry"	●	●	●
P2	Location of pressure port and suction port: Rotated 180° clockwise see Chapter 4.3, "Geometry"		●	●
P3	Location of pressure port and suction port: Rotated 270° clockwise see Chapter 4.3, "Geometry"	●	●	●

### **i** INFORMATION

- All codings Px possible for version with single pump, but not for version with tank or cover plate. After selecting one of the codings Px, only the option "X" is possible for the intake module.
- Cover plate variant D1 is not possible in combination with level switch D or S.

## 2.9 Pressure

Coding	Description
X	Series
A	<p>Pump with pressurised suction side, max 10 bar</p> <p>possible for version</p> <ul style="list-style-type: none"> <li>▪ Single pump</li> <li>▪ Cover plate</li> <li>▪ Tank</li> </ul> <div style="border: 1px solid #ccc; padding: 10px; margin-top: 10px;"> <p><b>!</b> <b>NOTICE</b></p> <p>Option only possible for LP 125-10 and LP 160-10</p> <p>The tank is not permanently watertight. Brief maximum pressure possible in the tank.</p> <p><b>Sample application:</b></p> <ol style="list-style-type: none"> <li>1. If more hydraulic fluid fed back into the tank via the plunger cylinder than can be removed, this can <b>briefly</b> result in overpressure in the tank. The overpressure reduces again via the vent screw.</li> <li>2. The suction side of the pump is pre-loaded with a separate pump.</li> </ol> </div>

## 2.10 Approval

Coding	Designation
N	Standard
EX	<p>ATEX (see <a href="#">B ATEX</a>)</p> <ul style="list-style-type: none"> <li>▪ only for single pump</li> </ul> <div style="border: 1px solid #ccc; padding: 10px; margin-top: 10px;"> <p><b>!</b> <b>NOTICE</b></p> <p>This must be correspondingly grounded for operating the pump in an approved ATEX zone in order to be able safely dissipate electrical charges in any case. This can be carried out via the piping, the attachment or a separate grounding:</p> <ul style="list-style-type: none"> <li>▪ In the case of a single pump: on the thread B2 with M6 or M8 on the pump cylinder (LP 80) or flange (LP 125 or LP 160), see <a href="#">Chapter 4.1, "Hydraulic pump"</a> (legend point 5).</li> </ul> <p>The customer is responsible for the grounding themselves.</p> </div>

### 3.1 General data

<b>Conformity</b>	<ul style="list-style-type: none"> <li>▪ Declaration of incorporation according to Machinery Directive 2006/42/EC see <a href="#">B 7280</a></li> </ul>
<b>Version / Model</b>	<ul style="list-style-type: none"> <li>▪ Single pump</li> <li>▪ Hydraulic power pack with various cover plate versions</li> <li>▪ Hydraulic power pack with various tank sizes</li> </ul>
<b>Pump version</b>	<ul style="list-style-type: none"> <li>▪ Air-driven hydraulic pump</li> </ul>
<b>Operating mode</b>	<ul style="list-style-type: none"> <li>▪ Continuous operation with constant load (S1)</li> <li>▪ Short period operation (S2)</li> <li>▪ Periodic intermittent operation (S3)</li> <li>▪ Continuous operation with intermittent load (S6)</li> </ul>
<b>Installation position</b>	<ul style="list-style-type: none"> <li>▪ vertical: in the case of tank version or cover plate version</li> <li>▪ any: in the case of single pump</li> </ul>
<b>Material</b>	<ul style="list-style-type: none"> <li>▪ Control module: aluminium alloy, anodised</li> <li>▪ Silencer: plastic</li> <li>▪ Pipe module: steel; electro-galvanised</li> <li>▪ Intake module: steel; electro-galvanised</li> <li>▪ Pump module: steel, electro-galvanised, aluminium alloy, anodised</li> <li>▪ Cover plate, tank: steel; electro-galvanised</li> </ul>
<b>Attachment</b>	<ul style="list-style-type: none"> <li>▪ Single pump with pump version coding <b>A</b> (see <a href="#">Chapter 2.2, "Pump version"</a>) on cover plate / tank: Attachment by means of grub screws</li> <li>▪ Single pump with pump version coding <b>P</b> (see <a href="#">Chapter 2.2, "Pump version"</a>): Attachment to side of the pump cylinder (LP 80) / side of the flange (LP 125, LP 160)</li> <li>▪ Hydraulic power pack with cover plate / tank: 4 x thread on cover plate</li> </ul> <div style="border: 1px solid #ccc; padding: 10px; margin-top: 10px;"> <p><b>! NOTICE</b>  LP 80, LP 125: In the case of attachment to the flange: depending on the installation conditions, take a spacer of 5 mm into consideration, as the cylinder tube protrudes 2.5 mm over the supporting surface of the thread.  see <a href="#">Chapter 4.3, "Geometry"</a></p> </div>
<b>Ports/connections</b>	<ul style="list-style-type: none"> <li>▪ <b>P</b> = oil pressure outlet</li> <li>▪ <b>R</b> = oil reflux</li> <li>▪ <b>S</b> = oil suction port (only in case of cover plate version or single pump without intake module)</li> <li>▪ <b>L</b> = compressed-air connection</li> </ul>
<b>Hydraulic fluid (Hydraulics side, pump)</b>	<p>Hydraulic fluid, according to DIN 51524 Parts 1 to 3; ISO VG 10 to 68 according to DIN ISO 3448  Viscosity range: 4 – 1100 mm<sup>2</sup>/s *  Optimal operating range: approx. 4 – 200 mm<sup>2</sup>/s *  Also suitable for biologically degradable hydraulic fluids type HEPG (polyalkylene glycol) and HEES (synthetic ester) at operating temperatures up to approx. +70°C.  * Deviation of the values possible. Influencing factors: Viscosity, operating point, application (hydr. overall design), pump type.</p>

Cleanliness level	Recommended cleanliness as per ISO 4406, see <a href="#">Oil recommendations: D 5488/1</a>
Temperatures	Environment: approx. +5 ... +40 °C, hydraulic fluid: 0 ... +80 °C, ensure the correct viscosity range. Biologically degradable hydraulic fluids: note manufacturer specifications. With consideration for the seal compatibility, not above +70°C. Lower (starting) temperatures on request. Compressed air temperature: +5 ... +40 °C
Air consumption	see <a href="#">Chapter 3.4, "Characteristic lines"</a>
Compressed air (air-side, drive)	compressed air prepared from commercially available service units <ul style="list-style-type: none"> <li>▪ Solid particles: class 7</li> <li>▪ Water: class 4</li> <li>▪ Oil: class 4</li> </ul> <p>The use of an improved classification of the class of water can play a role in delaying the effect of freezing. Commercially available maintenance units consisting of an air filter (filter cartridge of approx. 5 µm) with water separator, pressure reducing valve (pressure reducer), lubricator and pressure gauge are required for proper compressed-air preparation and safe and reliable functioning of the pumps. Maintenance data, see <a href="#">Chapter 6.1, "Maintenance unit"</a> Operation with explosive pressurised media is not permitted.</p>

**! NOTICE**

The energy required to operate the air pump is supplied to the system via compressed air. When the air pump is operated, the compressed air is expanded, resulting in a cooling effect due to the expansion. The working process therefore cools the air and the pump.

If the **ambient temperature** and/or the temperature of the compressed air is below the specified **limits**, the expansion cold can cause moisture to precipitate in the form of small water droplets, which then freeze into small ice crystals. The ice crystals settle on the inside of the silencer. **The ice layer that forms then creates a dynamic pressure and brings the working process to a halt.**

In general, the likelihood of this **effect occurring is reduced** if there is **no moisture** precipitation during expansion. This is possible if **dried air is used to operate the air pump.**

### 3.2 Pressure and volumetric flow

Operating pressure	see <a href="#">Chapter 2.1, "Basic type, size and plunger pistons"</a> see <a href="#">Chapter 3.4, "Characteristic lines"</a> <ul style="list-style-type: none"> <li>▪ Hydraulics side, pump</li> <li>▪ Air side, drive: <math>p_{L \max} = 10 \text{ bar}</math></li> </ul> <div style="border: 1px solid black; padding: 5px; margin-top: 10px;"> <p><b>! NOTICE</b> Make sure that the pneumatic maximum pressure is not exceeded.</p> </div>
Flow rate	see <a href="#">Chapter 2.1, "Basic type, size and plunger pistons"</a>

### 3.3 Weight

Single pump without pipe module and without intake module	<b>Type</b>			<div style="border: 1px solid gray; padding: 5px;"> <p><b>i INFORMATION</b> Weight depends on the size of the pump piston</p> </div>
		LP 80..X	= 4.45 kg	
		LP 125..X	= 5.89 to 6.74 kg	
		LP 160..X	= 7.95 to 8.8 kg	
Pipe module	<b>Type</b>			
		LP 80..R	= 0.32 kg	
		LP 125..R	= 0.52 kg	
		LP 160..R	= 0.52 kg	
Intake module	<b>Coding</b>			
	<b>for LP 80:</b>			
		S35	= 0.17 kg	
		S60	= 0.26 kg	
		S100	= 0.38 kg	
		S200	= 0.65 kg	
	<b>for LP 125:</b>			
		S65	= 0.29 kg	
		S75	= 0.32 kg	
		S165	= 0.60 kg	
		S250	= 0.86 kg	
	<b>for LP 160:</b>			
		S85	= 0.33 kg	
		S140	= 0.50 kg	
	S220	= 0.77 kg		
Tank (incl. cover plate and piping)	<b>Coding</b>			
		B4	= 5.7 kg	
		B10	= 8.5 kg	
		B25	= 15.1 kg	
Cover plate	<b>Coding</b>			
		D4	= 2.2 kg	
		D10	= 3.1 kg	
		D25	= 6.25 kg	
Level switch	<b>Coding</b>			
		S, D	= 0.2 kg	

### Example 1:

LP 80-10 /B4-D-K1-NBR-X..

Category	Pump	Tank	Level switch	Total weight
Selection	LP 80..X	B4	D	
Individual weights	4.45 kg	5.7 kg	0.2 kg	= 10.35 kg

### Example 2:

LP 125-12 /D4-X-S250-NBR-X..

Category	Pump	Cover plate	Intake module	Total weight
Selection	LP 125..X	D4	S250	
Individual weights	5.9 kg	2.2 kg	0.86 kg	= 9.96 kg

## 3.4 Characteristic lines

Measured at viscosity of the hydraulic fluid 40 mm<sup>2</sup>/s

Reference values for delivery flow and pressure depending on the operating pressure \*.

The reference value for the air required refers to the normal condition.

Values ±5% (hydraulic) and ±10% (pneumatic) are within the tolerance range.

\* Deviation of the values possible. Influencing factors: Viscosity, operating point, application (hydr. overall design), pump type.

### NOTICE

- The specified values apply for a pump commissioned after approx. 12 operating hours.  
Running-in behaviour: In the case of a newly commissioned pump (especially with a low pneumatic pressure in combination with simultaneously high hydraulic pressure), the efficiency can deviate 5 - 25% downwards!
- When operating with a very high pneumatic flow rate (maximum performance data), the supply line has to have a sufficiently large cross-section with regard to the length in order that the required pneumatic pressure is applied to the pump. Take into account dynamic pressure!
- Dynamic pressure (for characteristic line, see ⊕): The area marked to the right of/below this characteristic line cannot be reached. This concerns the operating points with high delivery flow rates (delivery flow axis Q) and also a low hydraulic pressure (hydraulic operating pressure axis p<sub>Hy</sub>). The characteristic line is not to be viewed as fixed. The values depend on the downstream hydraulic system and the associated hydraulic counter-pressure.

**LP 80**

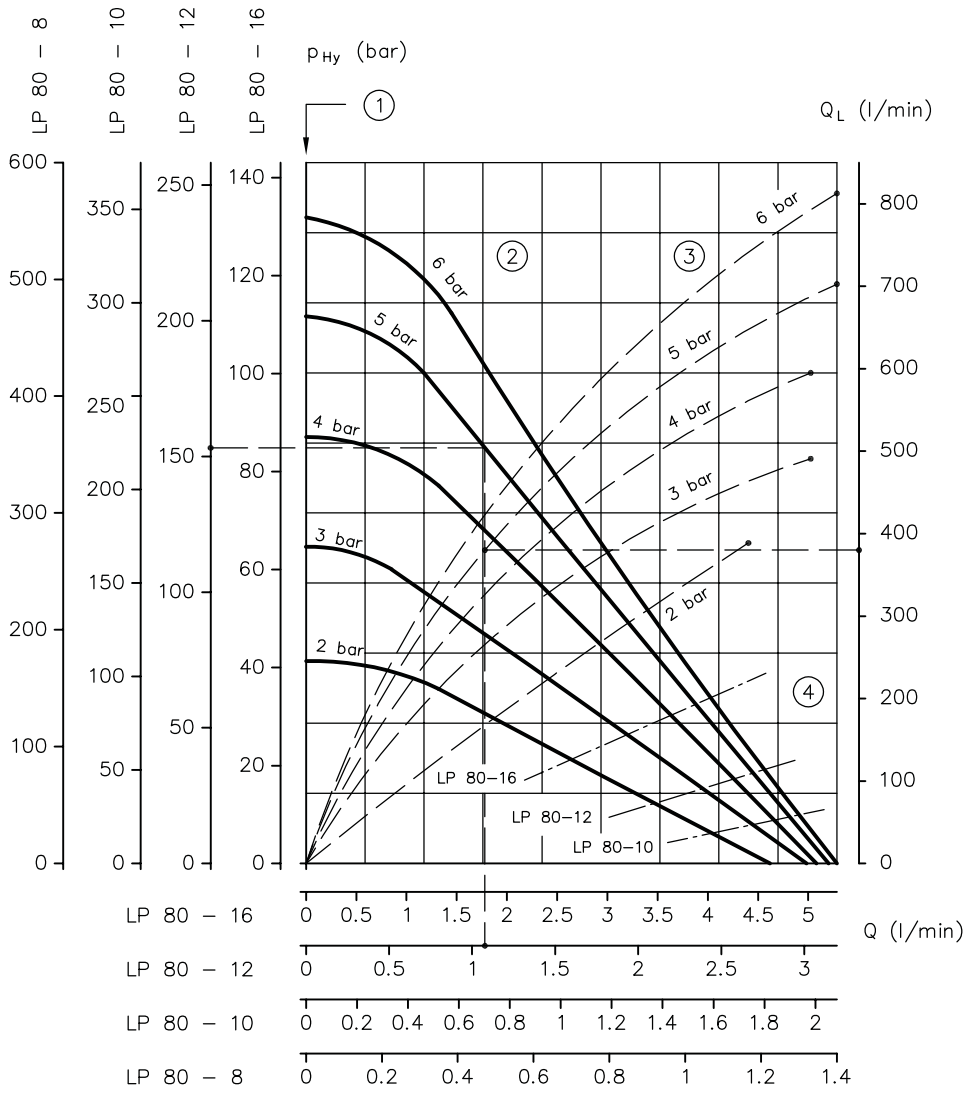

$Q$  delivery flow (l/min);  $p_{Hy}$  hydraulic operating pressure (bar);  $Q_L$  air consumption (l/min)

- 1 Stand-still pressure
- 2 Operating air pressure  $p_L$
- 3 Air consumption at  $p_L$
- 4 Dynamic pressure

**Example** At 154 bar consumer pressure  $p_{Hy}$  and 5 bar operating air pressure – an LP 80-12 achieves a flow rate  $Q$  of approx. 1.1 l/min (at an air consumption  $Q_L$  of approx. 380 l/min), see dotted spider line. The stand-still air pressure is approx. 3.9 bar (air pressure at which the pump starts to supply medium), at a consumer pressure of 154 bar.



### LP 125

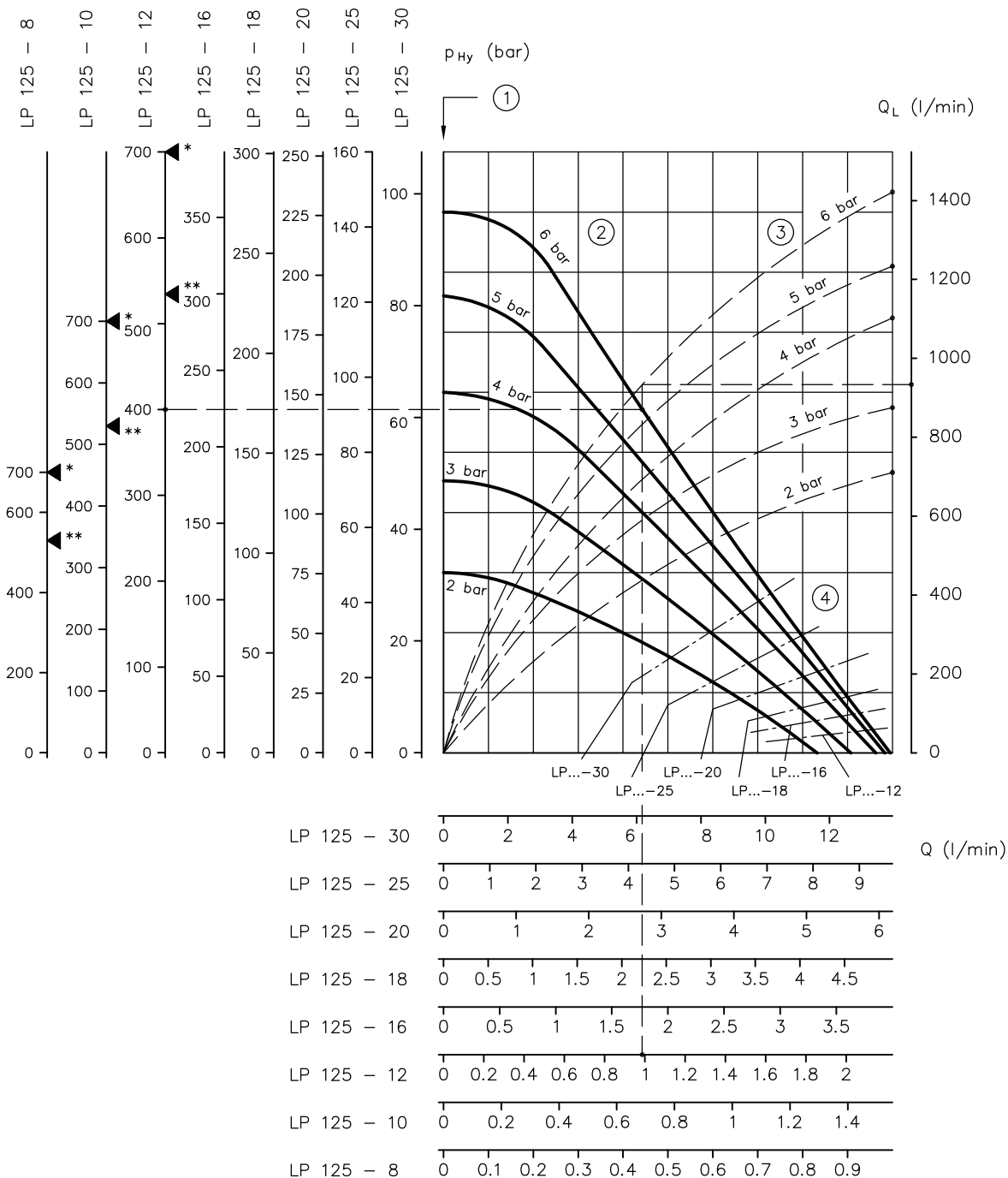

$Q$  delivery flow (l/min);  $p_{Hy}$  hydraulic operating pressure (bar);  $Q_L$  air consumption (l/min)

- \* Pressure  $p_{max} = 700$  bar
- \*\* In case of pipe R8: Pressure  $p_{max} = 530$  bar
- 1 Stand-still pressure
- 2 Operating air pressure  $p_L$
- 3 Air consumption at  $p_L$
- 4 Dynamic pressure

**Example** At 400 bar consumer pressure  $p_{Hy}$  and 6 bar operating air pressure, an LP 125-12 achieves a delivery flow rate  $Q$  of approx. 1.0 l/min (at an air consumption  $Q_L$  of approx. 920 l/min), see dotted spider line. The stand-still air pressure is approx. 3.8 bar (air pressure at which the pump starts to supply medium), at a consumer pressure of 400 bar.

**LP 160**

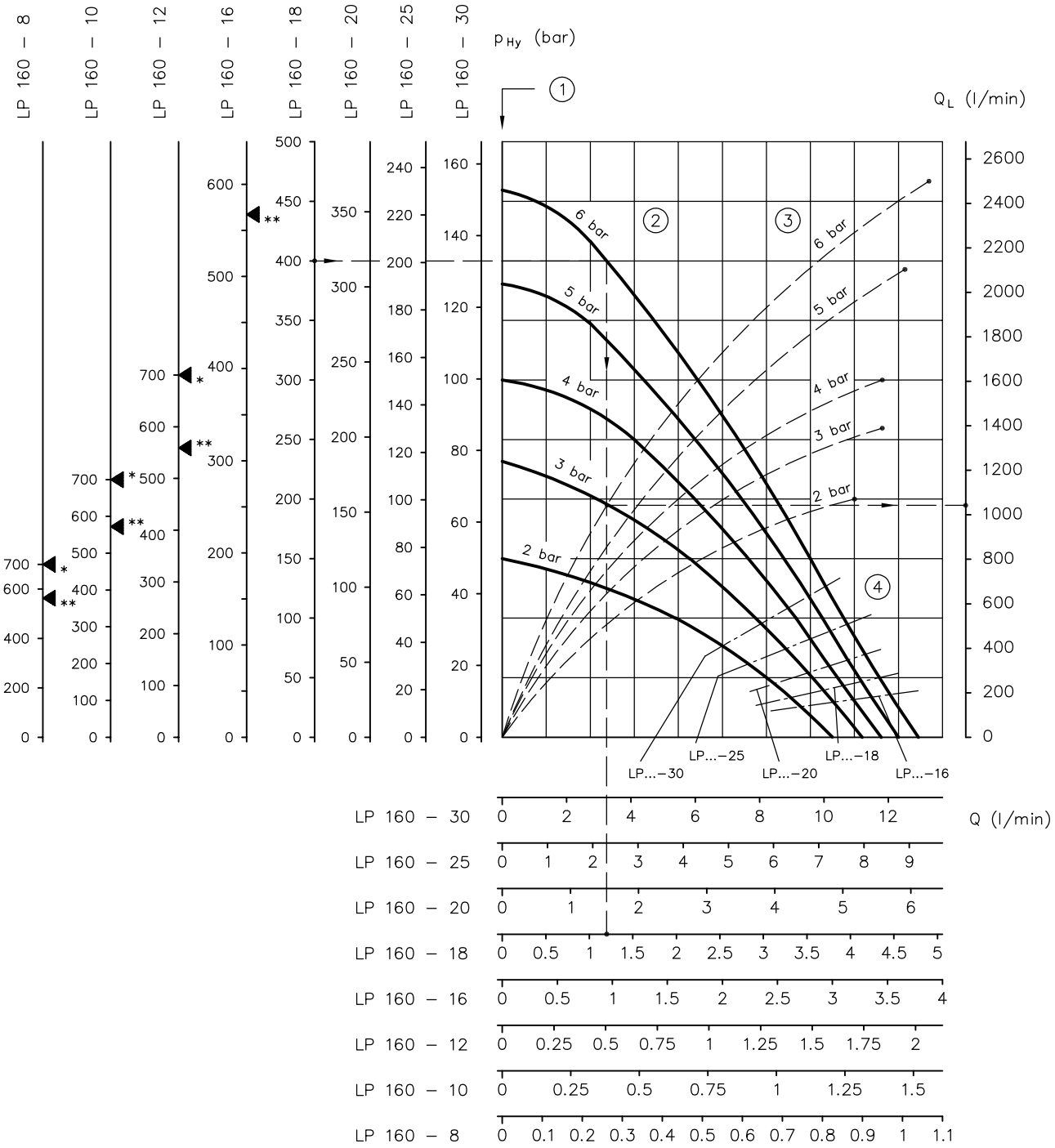

$Q$  delivery flow (l/min);  $p_{Hy}$  hydraulic operating pressure (bar);  $Q_L$  air consumption (l/min)

- \* Pressure  $p_{max} = 700$  bar
- \*\* In case of pipe R8: Pressure  $p_{max} = 530$  bar
- 1 Stand-still pressure
- 2 Operating air pressure  $p_L$
- 3 Air consumption at  $p_L$
- 4 Dynamic pressure

**NOTICE**

The specified values tend to be slightly worse with large piston sizes (e.g. LP 160-30) due to the dynamic pressure generated in the system.

**Example** At 400 bar consumer pressure  $p_{Hy}$  and 6 bar operating air pressure – an LP 160-18 achieves a delivery flow  $Q$  of approx. 1.2 l/min (at an air consumption  $Q_L$  of approx. 1050 l/min), see dotted spider line. The stand-still air pressure is approx. 5.3 bar (air pressure at which the pump starts to supply medium), at a consumer pressure of 400 bar.

### 3.4.1 Running noise

Acoustic data measured at viscosity at DTE22 of  $\sim 50 \text{ mm}^2/\text{s}$

Measured in the acoustic measurement chamber according to ISO 3744, distance between sound sensor and pump ( $d$ ) = 1 m.

The running noise depending on the operating air pressure. The exhaust air silencer optimally reduces it.

#### LP 80

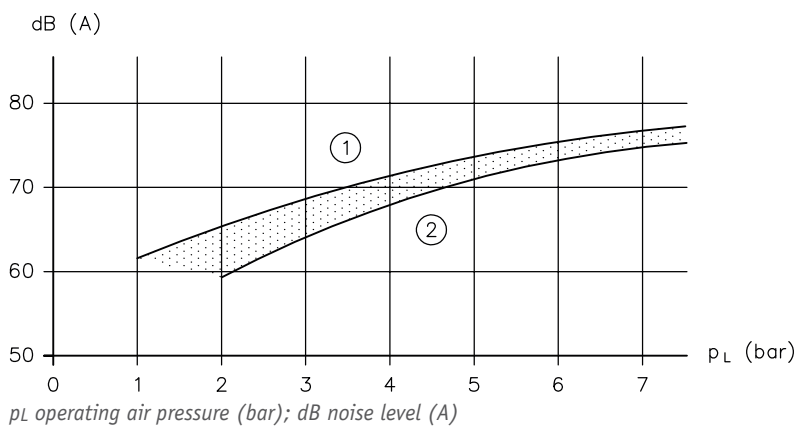

- 1 Hydraulic operating pressure  $p = 0$
- 2 Pressure against  $p_{\max}$  (near stand-still pressure)

#### LP 125

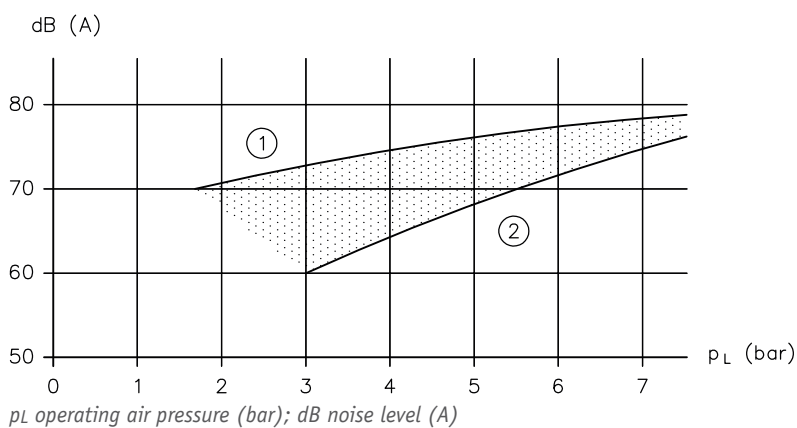

- 1 Hydraulic operating pressure  $p = 0$
- 2 Pressure against  $p_{\max}$  (near stand-still pressure)

**LP 160**

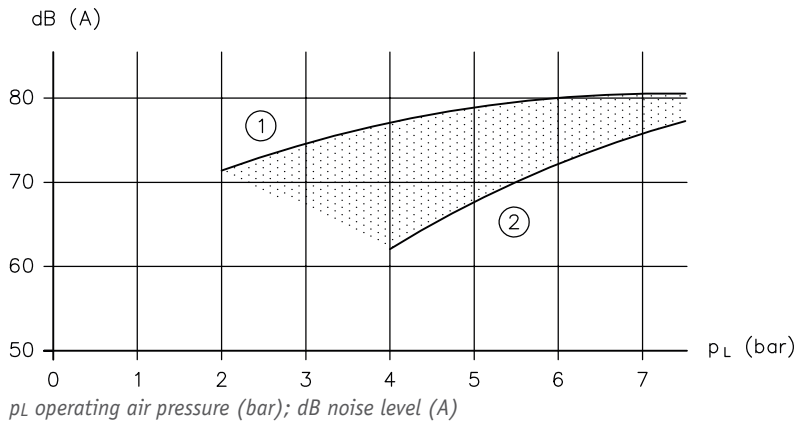

- 1 Hydraulic operating pressure  $p = 0$
- 2 Pressure against  $p_{max}$  (near stand-still pressure)

### 3.5 Additional options

#### 3.5.1 Level switch

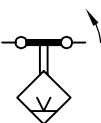
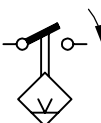
	B4, B10	B25
Max. voltage	50 V AC 70 V DC	36 V AC/DC
Max. AC/DC current	0.5 A	0.5 A
Max. AC/DC switching capacity	30 W	10 W
Electrical connection	Cable	Fitting PG 7
Circuit symbol	Coding <b>D</b> (N/C contact) 	Coding <b>S</b> (N/O contact) 

## 4 Dimensions

All dimensions in mm, subject to change.

### 4.1 Hydraulic pump

#### 4.1.1 LP 80

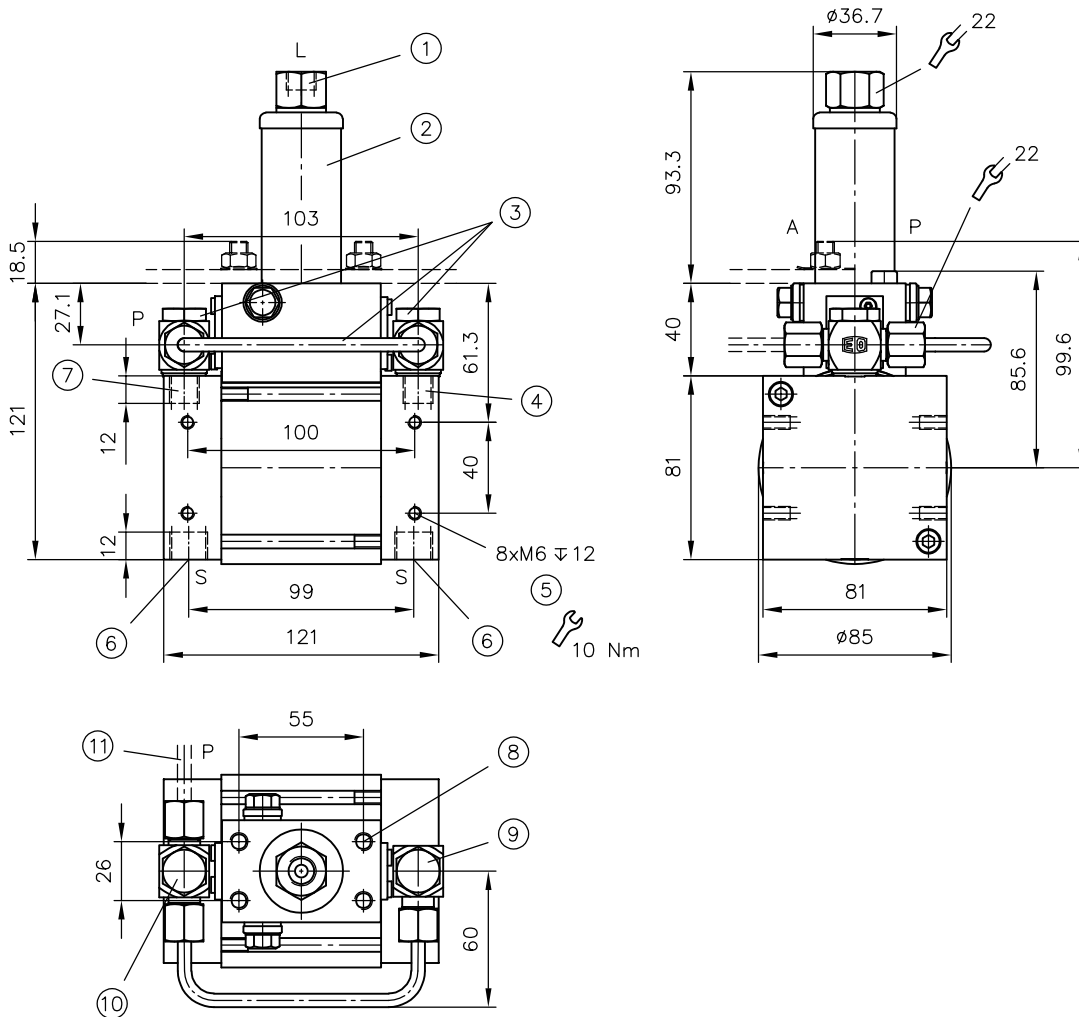

- 1 Compressed-air port L: G 1/4
- 2 Silencer
- 3 Piping omitted for version LP 80-...-...-X (pump without pipe module)
- 4 Pressure connection P 2: G 1/4 for version LP 80-...-...-X (pump without pipe module)
- 5 Mounting thread B 2 for "P" assembly, for ATEX: possible grounding point
- 6 Suction port S: G 3/8: Screw-in hole similar to form X DIN 3852 Part 2
- 7 Pressure connection P 1: G 1/4 for LP 80-...-...-X (pump without pipe module)
- 8 Mounting thread B 1 for "A" assembly (screw tightening torque: max. 6 Nm)
- 9 Elbow pipe screw connection (only for variant pump with pipe module, coding R.)
- 10 Pipe screw connection T (only for variant pump with pipe module, coding R.)
- 11 High-pressure connection of seamless precision pipe (R8, pipe diameter 8 mm)

**Intake module LP 80**

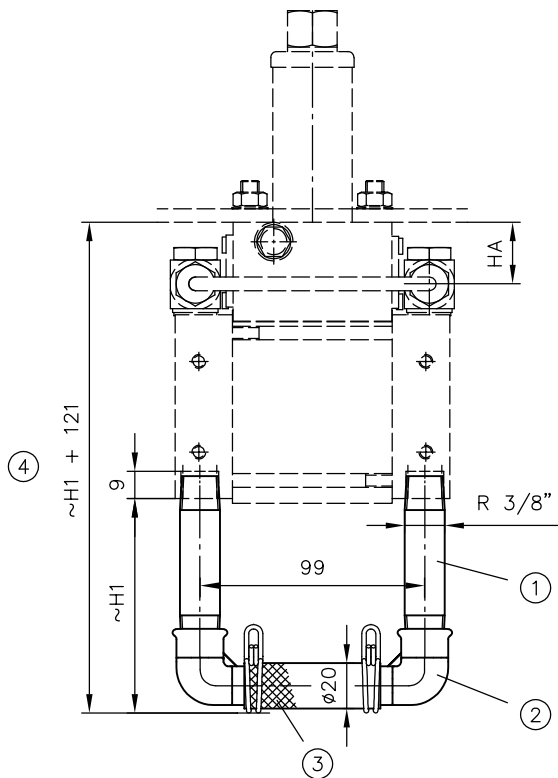

- 1 Double nipple
- 2 Fitting, elbow
- 3 Strainer, mesh size 0.8 mm
- 4 Total installation depth

**Coding**

suitable for max. clear tank height

	max. H1	H1 + H = Total height of pump without silencer = Pump in tank + safety clearance
S35	35	160
S60	60	185
S100	100	225
S200	200	325

**LP 80**

-8, -10, -12, -16

**HA**

27.8





**Intake module LP 125**

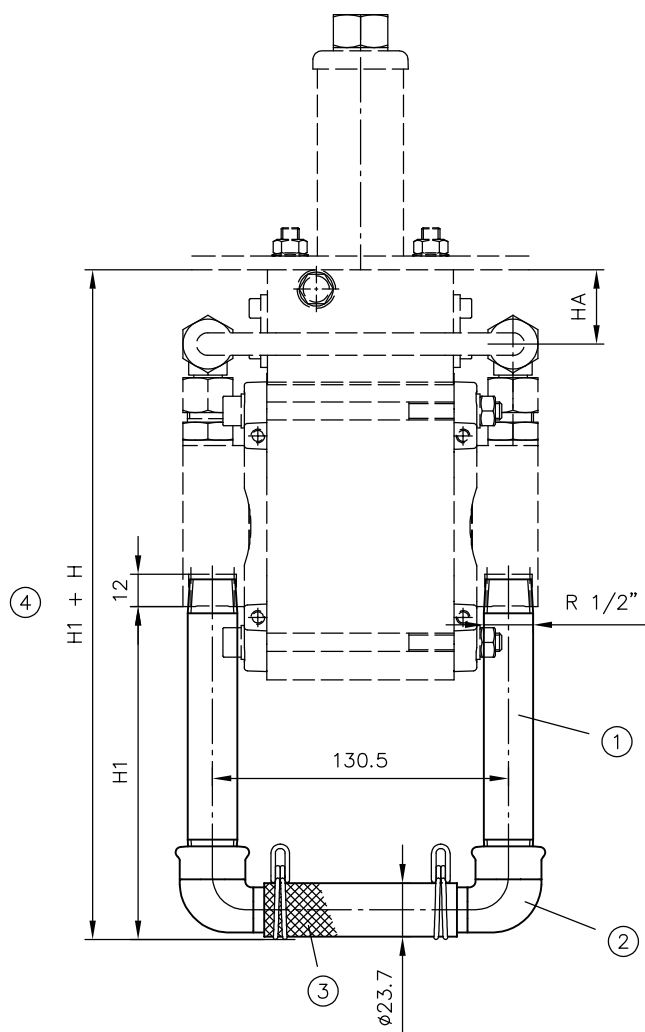

- 1 Double nipple
- 2 Fitting, elbow
- 3 Strainer, mesh size 0.8 mm
- 4 Total installation depth

Coding	max. H1
S65	65
S75	75
S165	165
S250	250

LP 125	H	HA
-8, -10, -12	148.5	33.2
-8, -10, -12 ... R8	148.5	35.2
-16, -18, -20	151	30.7
-16 ... R8	151	32.7
-25	153	27.9
-30	156	25.2

**4.1.3 LP 160**

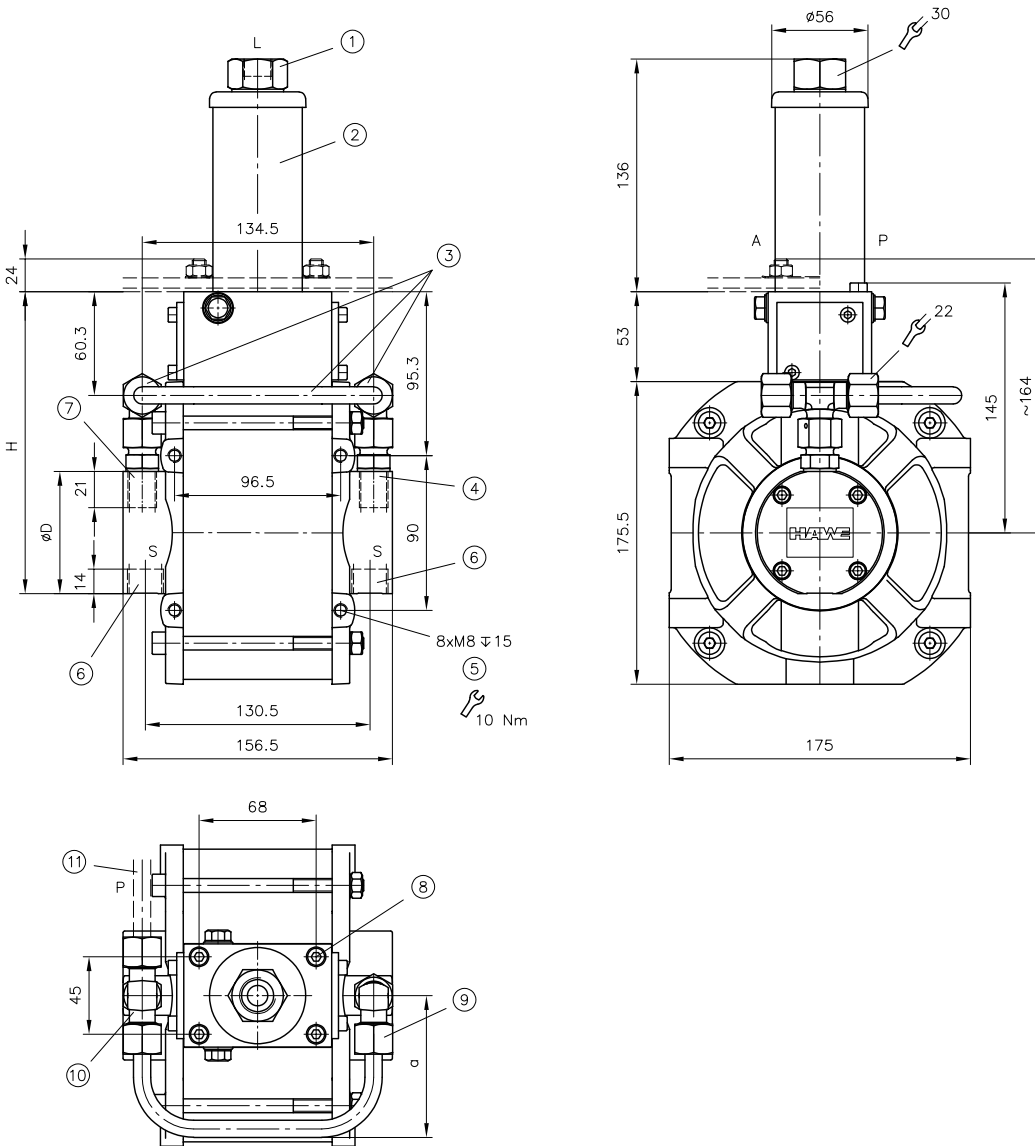

- 1 Compressed-air port L: G 1/2
- 2 Silencer
- 3 omitted for version LP 160-... X (pump without pipe module)
- 4 Pressure connection **P 2**: G 3/8 (or G 1/4 for version LP 160-8, -10, -12, -16) (pump without pipe module)
- 5 Mounting thread B 2 for "P" assembly, for ATEX: possible grounding point
- 6 Suction port **S**: G 1/2: Screw-in hole similar to form X DIN 3852 Part 2
- 7 Pressure connection **P 1**: G 3/8 (or G 1/4 for version LP 160-8, -10, -12, -16) (pump without pipe module)
- 8 Mounting thread B 1 for "A" assembly (screw tightening torque: max. 6 Nm)
- 9 Elbow pipe screw connection (only for variant pump with pipe module, coding R.)
- 10 Pipe screw connection T (only for variant pump with pipe module, coding R.)
- 11 High-pressure connection of seamless precision pipe (pump: R10, R8 or variable, if variant LP 160-...-...-X (pump without pipe module), cover plate / tank version: R 10 with pipe diameter 10 mm)

<b>LP 160</b>	<b>ØD</b>	<b>H</b>
-8, -10, -12	75	176.5
-16, -18, -20	80	179
-25	85	181.5
-30	90	184
<b>Pipe module</b>	<b>a</b>	
R8	82	
R10	82.5	

**i INFORMATION**  
The height H depends on the piston.

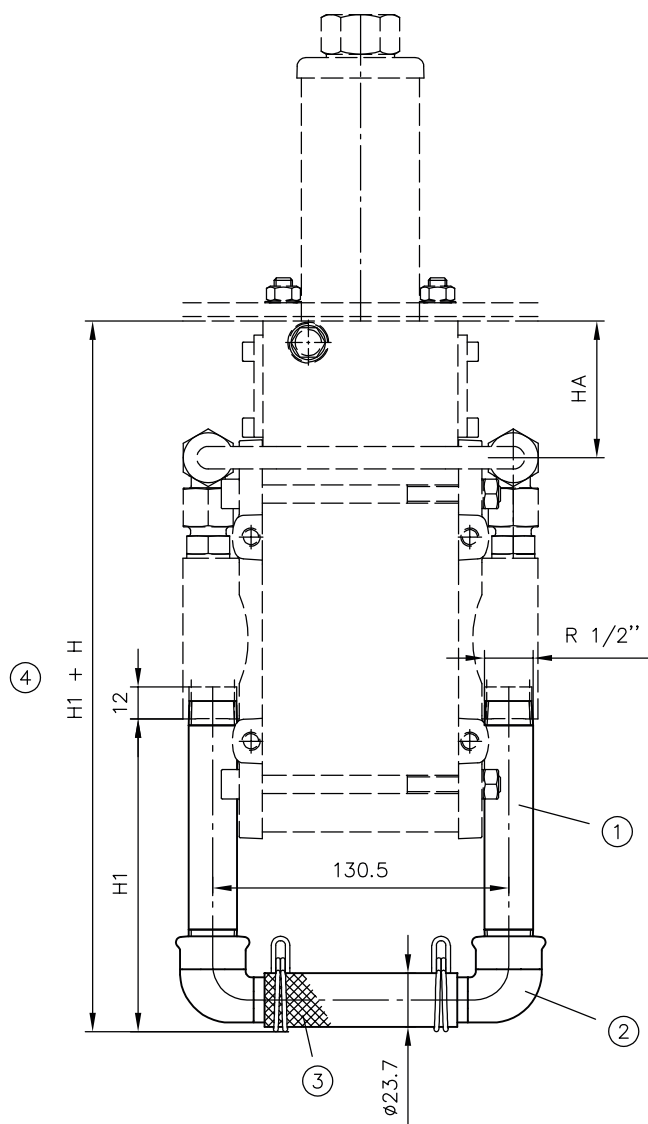
**Intake module LP 160**

- 1 Double nipple
- 2 Fitting, elbow
- 3 Strainer, mesh size 0.8 mm
- 4 Total installation depth

Coding	max. H1
S85	85
S140	140
S220	220

LP 160	H	HA
-8, -10, -12	175.5	60.2
-8, -10, -12 ... R8	175.5	62.5
-16, -18, -20	178	56.7
-16 ... R8	178	59.7
-25	180	54.9
-30	183	52.2

## 4.2 Hydraulic power pack

### 4.2.1 B4, D4

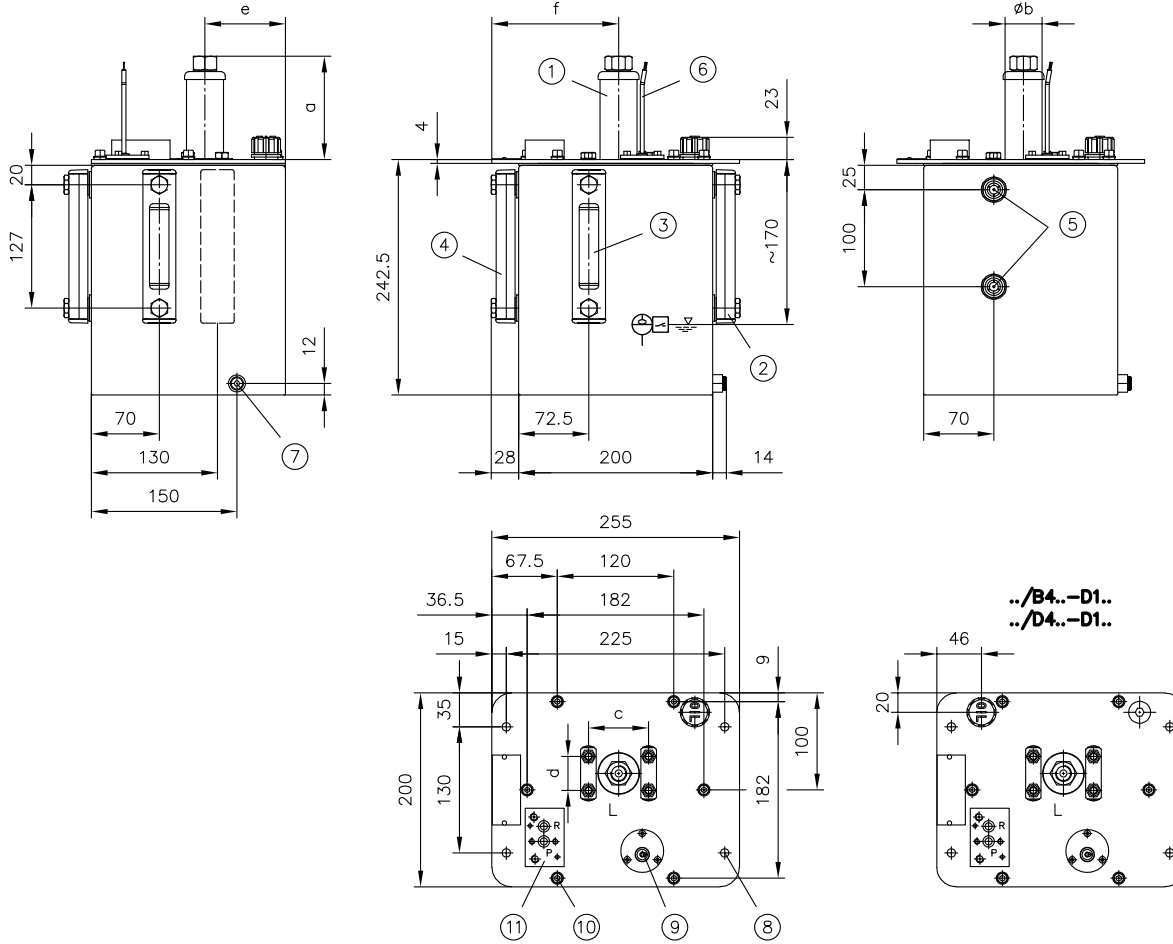

- 1 Silencer
- 2 Level gauge coding K1
- 3 Level gauge coding K2
- 4 Level gauge coding K3
- 5 Level gauge coding KK2
- 6 Connection cable for level switch approx. 350 mm long
- 7 Oil drain screw G 1/8
- 8 Attachment 4x  $\varnothing 9$  for the hydraulic power pack in the hydraulic system
- 9 in case of version with level switch
- 10 Pump attached to cover plate with 6x grub screw/M8 nut
- 11 Connection base P, R (hydraulic port),  
see Chapter 4.4, "Hydraulic connections"

Type	a	$\varnothing b$	c	d	e	f
LP 80	88	36.7	55	26	80	127.5
LP 125	107	40.3	62	35	83	130.5

Ports (ISO 228-1)	
Type	L
LP 80	G 1/4
LP 125	G 3/8

## 4.2.2 B10, D10

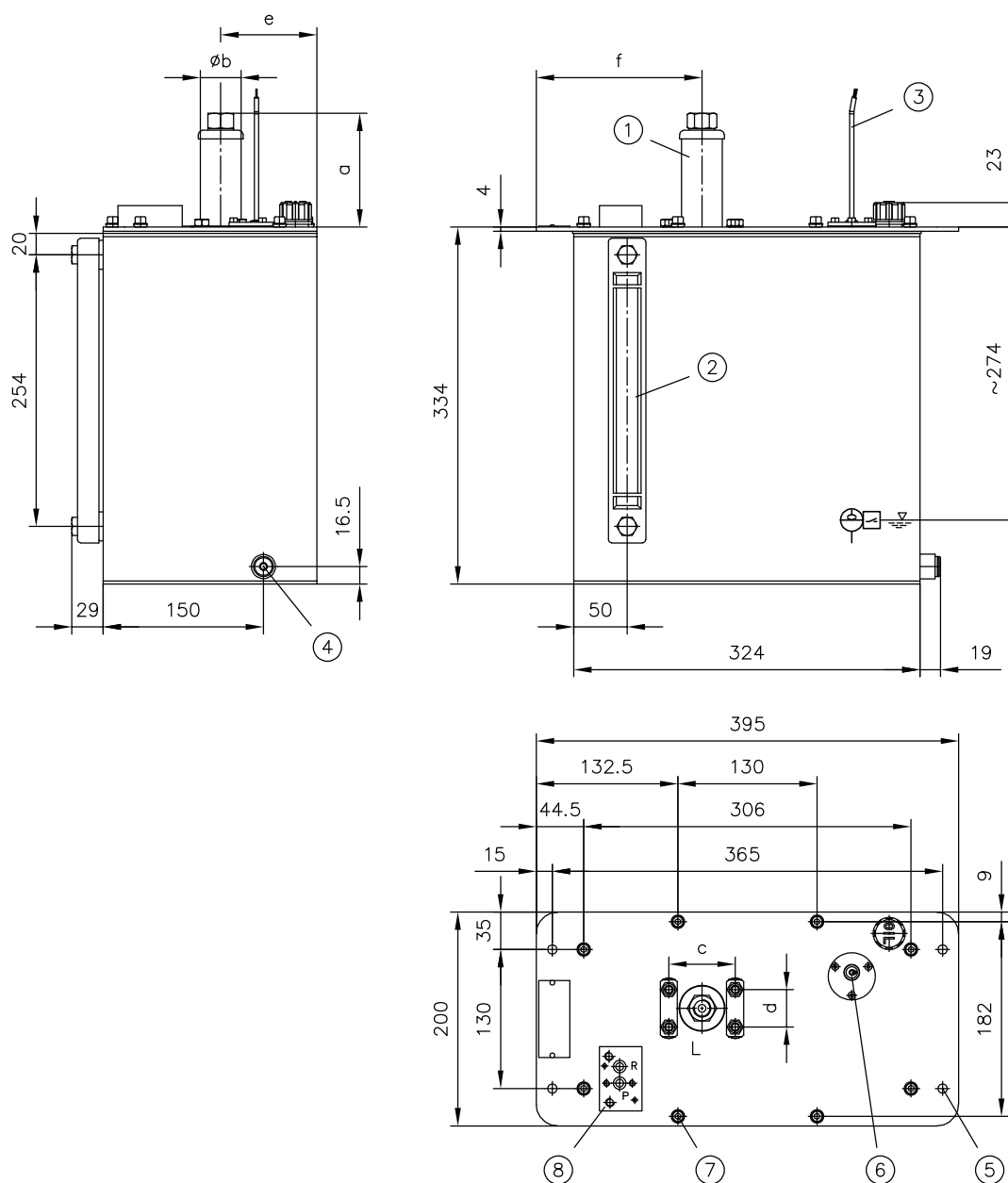

- 1 Silencer
- 2 Level gauge coding K2
- 3 Connection cable for level switch approx. 350 mm long
- 4 Oil drain screw G 1/4
- 5 Attachment 4x  $\varnothing 9$  for the hydraulic power pack in the hydraulic system
- 6 in case of version with level switch
- 7 Pump attached to cover plate with 8x grub screw/M8 nut
- 8 Connection base P, R (hydraulic port),  
see Chapter 4.4, "Hydraulic connections"

Type	a	$\varnothing b$	c	d	e	f
LP 125	106.5	41	62	35	90	155
LP 160	130	56	68	45	95	197.5

Ports (ISO 228-1)	
Type	L
LP 125	G 3/8
LP 160	G 1/2

**4.2.3 B25, D25**

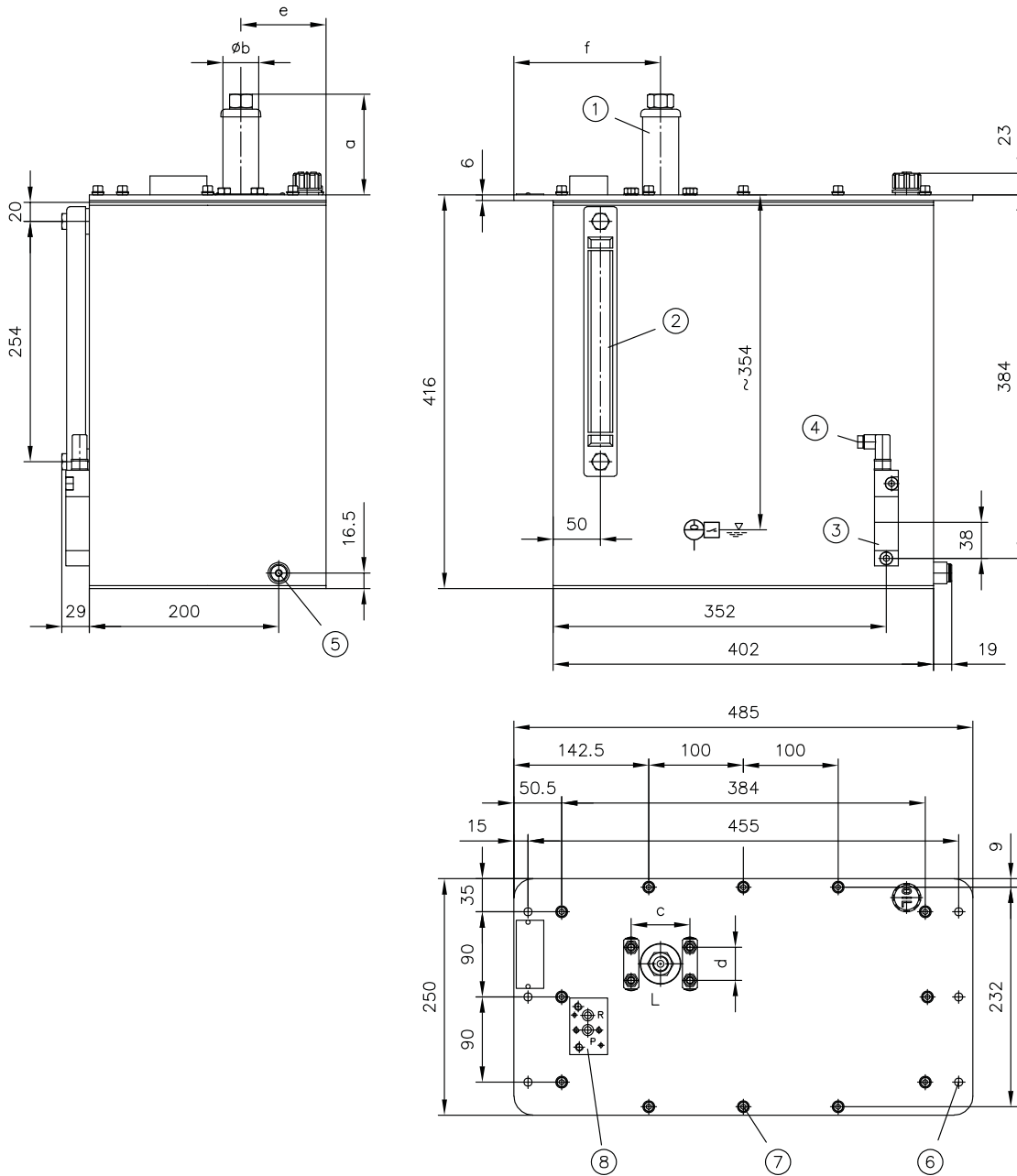

- 1 Silencer
- 2 Level gauge coding K2
- 3 Level switch
- 4 Cable fitting Pg 7
- 5 Oil drain screw G 1/4
- 6 Attachment 4x Ø9 for the hydraulic power pack in the hydraulic system
- 7 Pump attached to cover plate with 12x grub screw/M8 nut
- 8 Connection base P, R (hydraulic port),  
see Chapter 4.4, "Hydraulic connections"

Type	a	Øb	c	d	e	f
LP 125	106.5	41	62	35	90	155
LP 160	130	56	68	45	125	242.5

Type	Ports (ISO 228-1)
	<b>L</b>
LP 125	G 3/8
LP 160	G 1/2

## 4.3 Geometry

### Location of pressure port and suction port

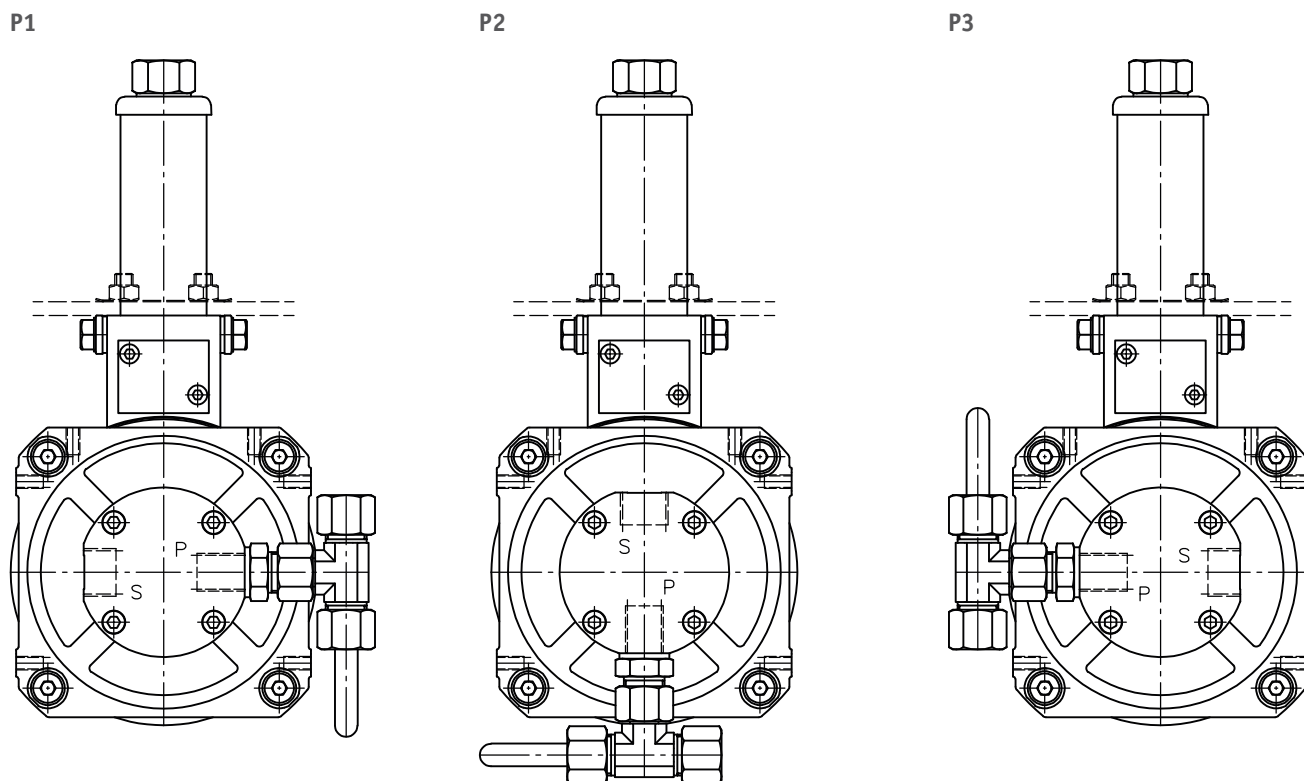

#### NOTICE

LP 80, LP 125:

- In the case of attachment to the flange: depending on the installation conditions, take a spacer of 5 mm into consideration, as the cylinder tube protrudes 2.5 mm over the supporting surface of the thread.

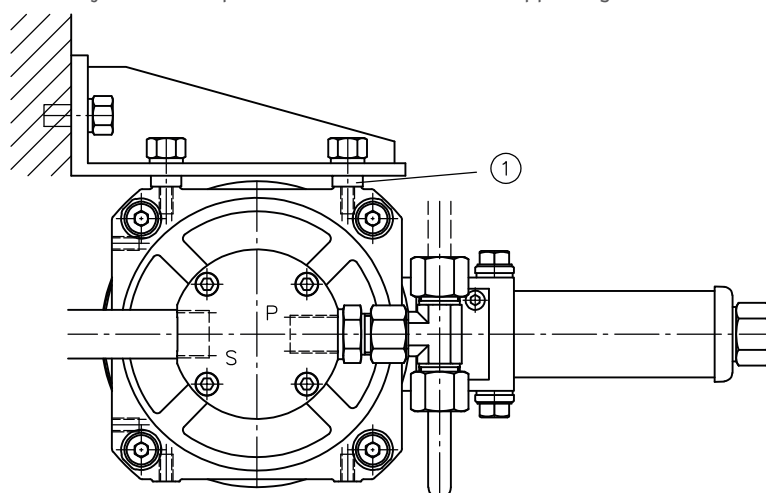

1 Wall clearance with spacers

LP 125:

- In the case of the geometry options P1, P2, P3: 2 additional threads (M6) are available on the top front face of the flange as shown in the drawings.

**NOTICE**

The pump cylinder can also be subsequently mounted offset by 90° by the customer, see B 7280. This enables the mounting space and in particular the location of the suction and pressure lines to be optimised.

The specified possible variants must be taken into account depending on the size, see Chapter 2.8, "Geometry".

### 4.4 Hydraulic connections

for cover plate / tank version

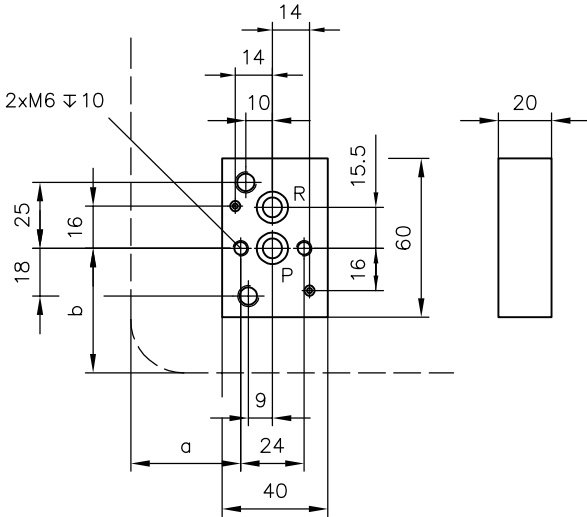

Type	Coding Tank / cover plate	a	b
LP 80	B4 / D4	40.5	44
	B4 / D4	41.5	47
LP 125	B10 / D10	66	40
	B25 / D25	66	90
LP 160	B10 / D10	63	36
	B25 / D25	108	56

**Example: connection block C 5, C 6**

**INFORMATION**

For further information see AB blocks: D 6905 AB, B blocks: D 6905 B, C blocks: D 6905 C. see Chapter 6.3, "Connection blocks"

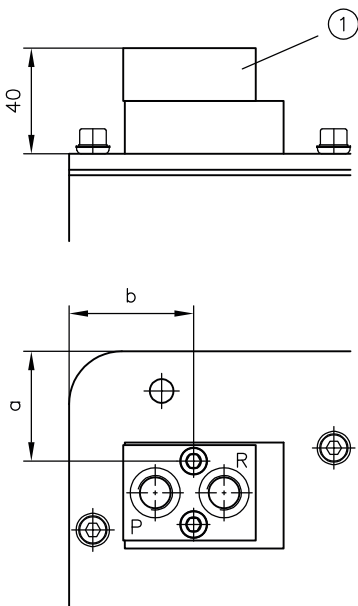

Type	Coding Tank / cover plate	a	b
LP 80	B4 / D4	40.5	44
	B4 / D4	41.5	47
LP 125	B10 / D10	66	40
	B25 / D25	66	90
LP 160	B10 / D10	63	36
	B25 / D25	108	56

1 Connection block C 5 or C 6, see D 6905 C



**5****Installation, operation and maintenance information****!** NOTICE

Available for this product: assembly instructions with notes on:

- intended use,
- operating and maintenance,
- Assembly information

Assembly instructions for air-driven hydraulic pump/power pack type LP: B 7280

Operating instructions for HAWE devices for designated use in potentially explosive atmospheres: B ATEX

## 6 Other information

### 6.1 Maintenance unit

Commercially available maintenance units consisting of an air filter (filter cartridge of approx. 5 µm) with water separator, pressure reducing valve (pressure reducer), lubricator and pressure gauge are required for proper compressed-air preparation and safe and reliable functioning of the pumps.

Type	Normal nominal flow (l/min)
LP 80	approx. 800
LP 125	approx. 1400
LP 160	approx. 2500

#### ! NOTICE

Values refer to operation under the conditions:

- 6 bar air pressure
- Idle on the hydraulic side

### 6.2 Long running times

A pressurised gas or gas mixture cools down during sudden, adiabatic expansion. Likewise, the components in which the expansion takes place and through which the cold gas flows until it exits, also cool down.

In typical operation, the components heat up between the work cycles during downtime intervals due to the higher ambient temperature. During continuous operation, the components can cool down to such an extent that water vapour condenses on them and frost forms or icing takes place.

On the hydraulic pump type LP, the reversing valve and the exhaust air silencer can ice up during exceptionally long running times. This applies in the case of continuous operation, depending on the temperatures of the surroundings and compressed air as well as the running time and the operating point of the pump (flow rate / pressure  $p_{new}$ ), in combination with air pressures larger than approx. 4 bar.

Use of antifreeze is possible if this is compatible with the seals used.

## 6.3 Connection blocks

A connection block is necessary to make an air-driven hydraulic power pack ready for a hydraulic connection.

### **i** INFORMATION

When selecting one, take note of the specifications for the connection blocks and mounted directional valves.

When setting the pressure-limiting valve on the connection block, take note of the pump's and valve mounting's maximum permitted pressure.

Type	Description	Publication
<b>without coding</b>	Connection block is self-made, for hole pattern <a href="#">see Chapter 4, "Dimensions"</a>	
<b>AB</b>	For single-circuit pumps with a pressure-limiting valve and the possibility of direct mounting of directional valve banks <b>Optional:</b> <ul style="list-style-type: none"> <li>▪ Pressure filter or return line filter</li> <li>▪ Idle circulation valve</li> <li>▪ Accumulator charging valve</li> <li>▪ Proportional pressure-limiting valve</li> </ul>	<a href="#">D 6905 AB</a> <a href="#">SK 6905 AD</a>
<b>AB..X</b>	For single-circuit pumps with a component-approved pressure-limiting valve and the possibility of direct mounting of directional valve banks (for use in accumulator systems) <b>Optional:</b> <ul style="list-style-type: none"> <li>▪ Pressure filter or return line filter</li> <li>▪ Idle circulation valve</li> </ul>	<a href="#">D 6905 AB</a> <a href="#">SK 6905 AD TÜV</a>
<b>B</b>	For single-circuit pumps for the activation of single-acting cylinders with a pressure-limiting valve and drain valve <b>Optional:</b> <ul style="list-style-type: none"> <li>▪ Throttle valve</li> </ul>	<a href="#">D 6905 B</a>
<b>C</b>	For single-circuit pumps with connections P and R for direct piping	<a href="#">D 6905 C</a>

### **i** INFORMATION

The connection block type AB.../PMVP can be used as an idle circulation valve. Without power, the valve remains open from a minimum pressure of approx. 5 bar.

Sample application for idle circulations with solenoid valves; multiple pressure and idle intervals following in quick succession.

It may not be reasonable for the pump to be switched off during brief intervals. The pump only switches off once the complete pressure interval sequence has finished.

## 6.4 Directional valve banks

### Mounting of valve banks with connection block

- Mounting of valve banks with connection plate **S** behind a connection block AB, B or C.

Connection plate **S** only for the valve banks VB and BWN / BWH

Example:

**LP 80-10/B4-X-X-NBR-X-X-X**

**-AB 1 K B 380**

**-BWH 1 S - NN - 1 - 1 - G24**

#### **i** INFORMATION

The direct mounting of valve banks with directional valves on connection blocks enables a compact hydraulic unit to be assembled without the need for additional piping.

This applies to all types except type **C**.

#### **!** NOTICE

**Restrictions for weight reasons:**

Maximum number of valves that are permitted be installed: 6 (higher number on request)

#### **!** NOTICE

When mounting valve banks, check for potential collisions with the silencer, in particular for type VB, BWN, BWH.

Type	Description	p <sub>max</sub> (bar)	Publication
VB	Valve bank (directional seated valve)	700	D 7302
BWN, BWH	Valve bank (directional seated valve)	450	D 7470 B/1
SWR, SWS	Valve bank (directional spool valve)	315	D 7951
BA	Valve bank for the combination of different directional valves with connection pattern NG 6 in accordance with DIN 24 340-A6	400	D 7788
BVH	Valve bank (directional seated valve)	400	D 7788 BV
NBVP	Directional seated valve	400	D 7765 N
ROLV	Directional seated valve	400	D 8144
NSWP	Directional spool valve	315	D 7451 N
NSMD	Clamping module (Directional spool valve with a pressure reducing valve and acknowledge function)	120	D 7787
NZP	Intermediate plates with connection pattern NG 6 in accordance with DIN 24 340-A6	400	D 7788 Z
POL, PRL, PIL	Proportional directional spool valve	350	D 6394
PIH	Proportional directional spool valve	350	D 6418
SWPM	Directional valve	320	D 6420/1

### Direct mounting of valve banks

- Direct mounting of valve banks with connection plate **L** without preceding connection block.

Possible valve banks: VB 01, VB 11 (D 7302) or BWN 1, BWH 1 (D 7470 B/1)

Example:

**LP 125-16/B10-X-X-NBR-X-X-X-N**

**-VB 11 L P - HHH - 1**

## References

### Connection blocks

- Connection blocks for single-circuit pumps types AB, AL: D 6905 AB
- Connection blocks type B for hydraulic power packs: D 6905 B
- Connection blocks type C: D 6905 C

### Valves and valve banks

- Valve bank (directional seated valve) type VB: D 7302
- Valve bank (nominal size 6) type BA: D 7788
- Valve bank (directional seated valve) type BWN and BWH: D 7470 B/1

### Hand pumps

- Manual pump type H, HD and HE: D 7147/1
- Hand pump type CH: D 7147 CH

