

Directional spool valve type SG and SP

Product documentation

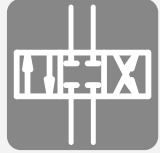

Single valve for pipe connection or manifold mounting

Operating pressure p_{\max} : 400 bar

Flow rate Q_{\max} : 100 lpm



© by HAWE Hydraulik SE.

The reproduction and distribution of this document as well as the use and communication of its contents to others without explicit authorization is prohibited.

Offenders will be held liable for the payment of damages.

All rights reserved in the event of patent or utility model applications.

Brand names, product names and trademarks are not specifically indicated. In particular with regard to registered and protected names and trademarks, usage is subject to legal provisions.

HAWE Hydraulik respects these legal provisions in all cases.

HAWE Hydraulik cannot provide individual guarantees that the stated circuits or procedures (including in part) are not subject to the intellectual property rights of third parties.

Printing date / document generated on: 22.04.2022

Contents

1	Overview of directional spool valves type SG and SP.....	4
2	Available versions.....	5
2.1	Basic type and size.....	5
2.2	Circuit symbol.....	6
2.3	Pressure-limiting valve (only type SG).....	8
2.4	Actuation.....	9
2.5	Pressure setting.....	17
3	Parameters.....	18
3.1	General data.....	18
3.2	Pressure and volumetric flow.....	18
3.3	Weight.....	19
3.4	Characteristic lines.....	19
3.5	Electrical data.....	21
4	Dimensions.....	24
4.1	Single valve for pipe connection type SG.....	24
4.2	Single valve for manifold mounting, type SP.....	27
4.3	Actuations.....	29
5	Installation, operation and maintenance information.....	39
5.1	Intended use.....	39
5.2	Assembly information.....	39
5.3	Operating instructions.....	40
5.4	Maintenance information.....	41

1**Overview of directional spool valves type SG and SP**

Directional spool valves are a type of directional valve. They control the direction of movement and the velocity of single and double-acting hydraulic consumers.

The directional spool valve type SG is available as a single valve for pipe connection. Type SP is available as a manifold mounting valve. Due to its robust design, operating pressures up to 400 bar are achievable. They are flexible in use and are available with various different circuit symbols and types of actuation. Intended applications include mobile hydraulics, in particular in special vehicles, in municipal trucks and in shipbuilding.

Features and benefits

- Sturdy design
- For general purpose use
- Wide variety of circuit symbols and types of actuation
- Proven for use even in the maritime environment

Intended applications

- Mining machinery
- Municipal trucks
- Shipbuilding
- Cranes and lifting equipment



Directional spool valve type SG

2 Available versions

Ordering example

SG 3	L	3E	- AK	- 120
				2.5 "Pressure setting"
				2.4 "Actuation"
				2.3 "Pressure-limiting valve (only type SG)"
				2.2 "Circuit symbol"
				2.1 "Basic type and size"

2.1 Basic type and size

Type	Ports to ISO 228-1		Flow rate Q_{max} (lpm)	Pressure p_{max} (bar) at port		Circuit symbol
	P, A, B	R		P, A, B	R	
Single valve for pipe connection						
SG 0	G 1/4	G 3/8	12	400	**	
SG 1	G 3/8		20			
SG 2	G 3/8		30			
SG 3	G 1/2		50			
SG 5	G 1		100			
Single valve for manifold mounting						
SP 1	*		12	400	**	
SP 3	*		50			
SP 5	*		100			

! DAMAGE

* Ports for a single valve for manifold mounting see Chapter 4.2, "Single valve for manifold mounting, type SP"

** The maximum return pressure is dependent on the pressure-limiting valve and actuation.

see Chapter 2.3, "Pressure-limiting valve (only type SG)"

see Chapter 2.4.1, "Manual actuation"

2.2 Circuit symbol

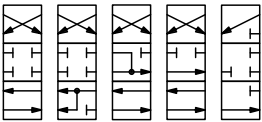
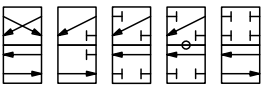
Coding	Description	Circuit symbol
G, C, D, E, N	<p>4/3 or 3/3 directional spool valve for parallel circuit</p> <p>Coding C:</p> <ul style="list-style-type: none"> ▪ Only for size 0, 1 <p>Coding N:</p> <ul style="list-style-type: none"> ▪ Only for size 1, 2, 3, 5 ▪ With SG 1 not for use in conjunction with a pressure-limiting valve 	<p style="text-align: center;">G C D E N</p> 
W, R, V, Q, Z	<p>4/2 or 3/2 directional spool valve for parallel circuit</p> <p>Coding R, V:</p> <ul style="list-style-type: none"> ▪ With SG 1 not for use in conjunction with a pressure-limiting valve <p>Coding Q:</p> <ul style="list-style-type: none"> ▪ Negative overlap (slight floating position between the two switching positions) ▪ Only for size 2, 3, 5 <p>Coding Z:</p> <ul style="list-style-type: none"> ▪ Only for size 2 ▪ Not for use in conjunction with a pressure-limiting valve <p>For coding V and Q the port R must be connected to the tank in order to drain away the leakage oil flow rate.</p>	<p style="text-align: center;">W R V Q Z</p> 

Coding	Description	Circuit symbol
L, LS, P, H, Y, S	<p>4/3 or 3/3 directional spool valve for series or parallel circuit. Not for use in conjunction with a pressure-limiting valve in a series circuit.</p> <p>Coding L:</p> <ul style="list-style-type: none"> With SG 0 and SG 5 not for use in conjunction with a pressure-limiting valve <p>Coding LS:</p> <ul style="list-style-type: none"> Special version to avoid decompression surges Only for SG 5, not for use in conjunction with a pressure-limiting valve <p>Coding P:</p> <ul style="list-style-type: none"> Only for size 0, 1, 2, 3 With SG 0 not for use in conjunction with a pressure-limiting valve <p>Coding H:</p> <ul style="list-style-type: none"> Only for SG 1, SP 1, SG 3 <p>Coding Y:</p> <ul style="list-style-type: none"> Only for SG 3 Not for use in conjunction with a pressure-limiting valve <p>Coding S:</p> <ul style="list-style-type: none"> Only possible for SG 2 in conjunction with a pressure-limiting valve, and for SG 3 <p>Coding L, LS, H, Y have a negative overlap (slight floating position between the switching positions). Coding P, S have a positive overlap (slight closed position between the switching positions).</p> <p>Note on LS: In shipbuilding, spool valves with large ports are often used because very long pipelines generally lead to high flow resistance values, even with lower flow rates. The decompression surges and pressure waves caused by large pipe volumes place additional stresses on hydraulic equipment. For version SG 5 LS the valve spool is designed so that a delayed build-up in pressure during switching is achieved by long control notches, and thus these pressure surges can be largely avoided. In addition the port sizes G 1 permit the use of Ø25 pipelines with correspondingly low flow resistance.</p>	

! DAMAGE

If several individual spool valves are used within a single system, consideration must be given to the type of circuit (parallel circuit or series circuit). For a series circuit the maximum permissible system pressure is the same as the maximum permissible return pressure. Therefore a series circuit is not always suitable for all versions and types of actuation.

Maximum permissible return pressure [see Chapter 2.4, "Actuation"](#)

2.3 Pressure-limiting valve (only type SG)

Coding	Description	Circuit symbol
Without coding	Without pressure-limiting valve	-
1 2	Pressure-limiting valve for SG 0, 1 Zinc die-cast spring housing, p_{max} at port R = 20 bar <ul style="list-style-type: none"> ▪ 1: fixed ▪ 2: adjustable 	<p>1, 3, 6</p>
3 4	Pressure-limiting valve for SG 2, 3, 5 Zinc die-cast spring housing, p_{max} at port R = 20 bar <ul style="list-style-type: none"> ▪ 3: fixed ▪ 4: adjustable 	
6 7	Pressure-limiting valve for SG 2, 3, 5 Steel spring housing p_{max} at port R > 20 bar (proof against pressure surges to 300 bar) <ul style="list-style-type: none"> ▪ 6: fixed ▪ 7: adjustable 	<p>2, 4, 7</p>
	Special version for special installations and marine applications	

! DAMAGE

The pressure in R is additional to the pressure setting.

! DAMAGE

The version with the pressure-limiting valve is available only for type SG and for parallel circuits.

see Chapter 2.1, "Basic type and size"

see Chapter 2.2, "Circuit symbol"

Adjustment range for the pressure-limiting valve

Coding	Description
Without coding	Without pressure-limiting valve
B	315 ... 400 bar
C	160 ... 315 bar
E	80 ... 160 bar
F	20 ... 80 bar

2.4 Actuation

2.4.1 Manual actuation

Coding	Description	Pressure p_{max} (bar)		Circuit symbol	View
		P, A, B	R		
AK, AKS AK1, AKS1	Manual operation with spring return <ul style="list-style-type: none"> AK: Standard version AKS: Special version with a corrosion-resistant steel shaft. Especially for maritime applications. For size 2, 3, 5 the lever housing has an additional flat grease nipple. Actuation supplement 1: without hand lever	400	SG: 315 SP: 100		
CK, CKS CK1, CKS1	Manual operation with 3-stage detent <ul style="list-style-type: none"> CK: Standard version CKS: Special version with a corrosion-resistant steel shaft. Especially for maritime applications. For size 2, 3, 5 the lever housing has an additional flat grease nipple. Actuation supplement 1: without hand lever	400	SG: 315 SP: 100		

! DAMAGE

For 4/2 and 3/2 directional spool valves, the 3rd switching position of the hand lever is blocked internally in the lever housing.

2.4.2 Manual actuation with contact switch

Coding	Description	Pressure p_{max} (bar)		Circuit symbol	View
		P, A, B	R		
PK, PK2	Manual operation with spring return and contact switch, hand lever upwards <ul style="list-style-type: none"> PK2: <ul style="list-style-type: none"> Without contact switch and switch retainer but with cam Only for size 2, 3, 5 	400	SG: 315 SP: 100		
UK, UK2	Manual operation with spring return and contact switch, hand lever to the side <ul style="list-style-type: none"> Only for size 2, 3, 5 UK2: <ul style="list-style-type: none"> Without contact switch and switch retainer but with cam 	400	SG: 315 SP: 100		

! DAMAGE

The contact switches are not adjusted by HAWE. They are to be adjusted when they are electrically connected to their switch retainers.

Size 0, 1

The switch is not pressed in the spool valve neutral position, for 3/3 directional spool valves it is also pressed in position a.

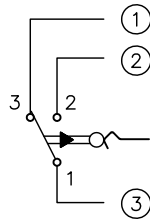
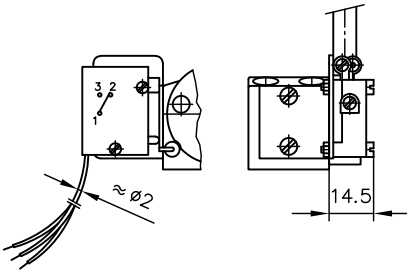

- 1 Normally open contact (blue)
- 2 N/C contact (grey)
- 3 Input (black)

Size 2, 3, 5

4/2, 3/2 and 4/3 directional spool valve

(Contact switch functions in positions a and b) The cam is symmetrical. The switch can be adjusted on the switch retainer in such a way that, in switching positions a or b, the contact bridge 11-12 can be used as a normally open contact or 23-24 can be used as a N/C contact, as required (switch is pressed in position 0).

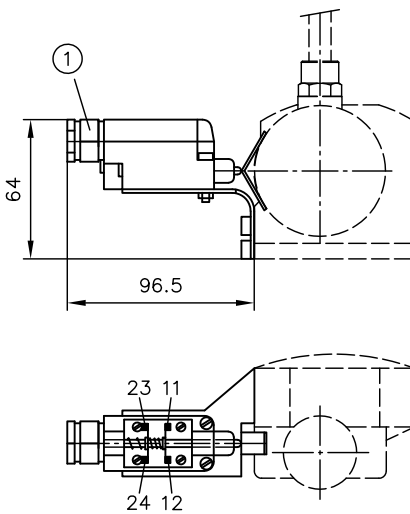

Neutral position

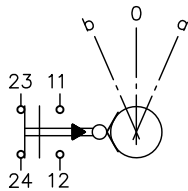

Switching position a or b

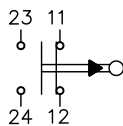

1 Cable fitting

3/3 directional spool valve

(Contact switch functions in position a) The cam is asymmetrical. The switch can be adjusted on the switch retainer in such a way that, in switching position a, for example, the contact bridge 11-12 can be used as a normally open contact. The switch can also be set so that both bridges are open in neutral position, and the bridge 11-12 is closed in switching position a and 23-24 is closed in switching position b.

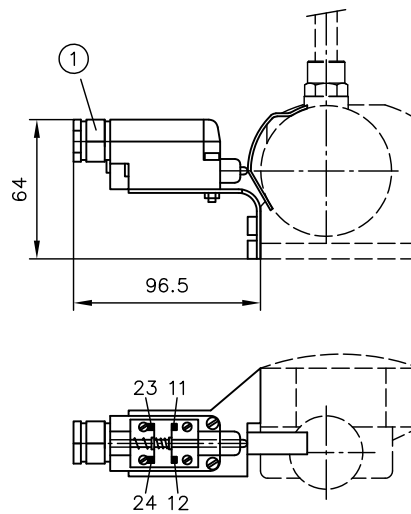

Neutral position and switching position b

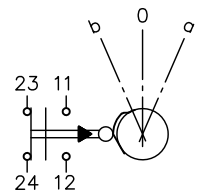

Switching position a

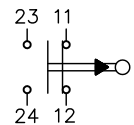

1 Cable fitting

2.4.3 Mechanical actuation

Coding	Description	Pressure p_{max} (bar)		Circuit symbol	View
		P, A, B	R		
RE	Roller head actuation <ul style="list-style-type: none"> ▪ RE: Single-stroke – Only for parallel circuit – Only for 4/2 or 3/2 directional spool valve 	400	100	RE 	
BE	Ball head actuation <ul style="list-style-type: none"> ▪ BE: Single-stroke – Only for size 2, 3 and 5 – Only for parallel circuit – Only for 4/2 or 3/2 directional spool valve 	400	100	BE 	

Assembly

- Roller head actuation: For lateral actuation by a cam or a control rod, a hardened plunger must have a roller bearing roller at its outer end. The plunger is installed in a flange housing with anti-twist protection, and is fitted with a strong return spring.
- Ball head actuation: For the axial direction of actuation the outer end is designed convex (without a roller).

The connection to the valve spool is made by a connecting rod sealed against the spring cavity of the plunger. This means that this type of actuation is not fully pressure compensated. Any pressure in the reflux of the directional spool valve adds a certain percentage to the force of the return spring. Allowance must be made for this when designing the external actuating elements.

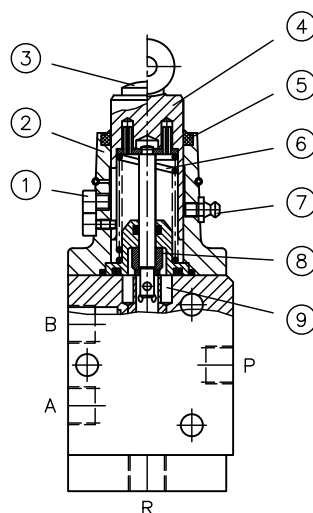

- 1 Anti-twist protection
- 2 Housing
- 3 Ball head
- 4 Roller head with roller bearing roller
- 5 Dirt scraper
- 6 Return spring
- 7 Grease nipple
- 8 for RE, BE
- 9 Reflux chamber of the directional spool valve

Actuation diagram

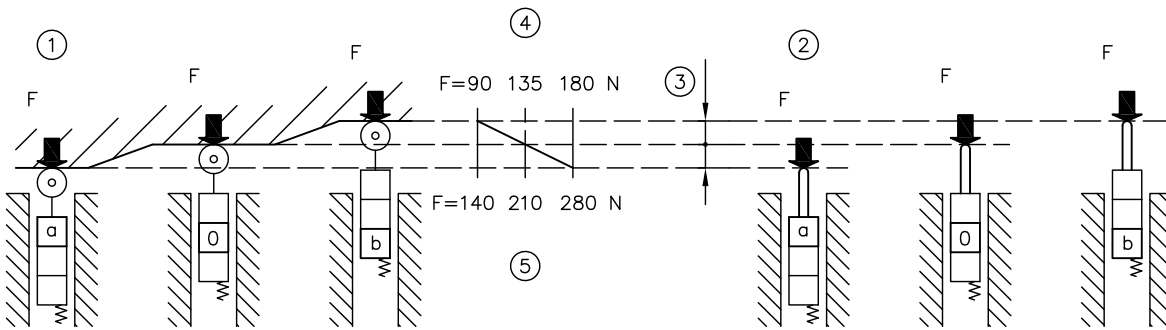

- 1 Roller head
- 2 Ball head
- 3 Switching travel
- 4 Spring force for spool valve size 0, 1
- 5 Spring force for spool valve size 2, 3, 5

Overall actuation force (N)

- for spool valve size 0, 1: $F_{ges} = F + 2.8 p_R$
- for spool valve size 2, 3, 5 (4): $F_{ges} = F + 5 p_R$

F (N) = see actuation diagram

p_R (bar) = pressure at port R (reflux)

Roller head actuation is preferred when actuation is by a cam or a control rod. The actuation curve should be configured and adjusted at assembly against the spool valve so that the spool stroke of the roller head is not pushed beyond the actuation path (3) from the 0 position into the a-position.



For a double stroke valve (RD, BD) the return spring always pushes the spool valve including the actuating part into the switching position b. In the installed condition the cam, control rod or other linkage elements should therefore be arranged so that in the home position or initial position the system adopts the 0 position.

2.4.4 Hydraulic or pneumatic actuation

Coding	Description	Pressure p_{max} (bar)		Circuit symbol	View
		P, A, B	R		
NE, ND, NDH Size 0, 1	Hydraulic or pneumatic actuation <ul style="list-style-type: none"> ▪ NE: Single-stroke ▪ ND: Double-stroke ▪ NDH: with manual override Only for parallel circuit	400	40		
NE, ND, NU, NUH Size 2, 3, 5	Pneumatic actuation <ul style="list-style-type: none"> ▪ NE: Single-stroke ▪ ND: Double-stroke ▪ NU: Reverse stroke ▪ NUH: with manual override Only for parallel circuit	400	30		
NM Size 2, 3, 5	Hydraulic actuation Single-stroke or double-stroke Only for parallel circuit	400	30		
KD, KM Size 2, 3, 5	<ul style="list-style-type: none"> ▪ KD: Combined pneumatic and manual actuation ▪ KM: Combined hydraulic and manual actuation Double-stroke Only for parallel circuit	400	12		

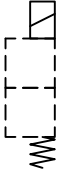
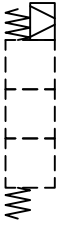
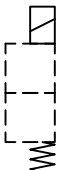
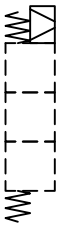
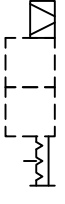
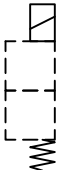
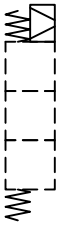
2.4.5 Electrical actuation

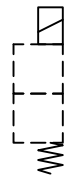
Coding	Rated voltage	Description	Pressure p _{max} (bar)		Circuit symbol
			P, A, B	R	
Size 0, 1					
ME 1 ME 2 ME 8	12 V DC 24 V DC 230 V AC	Single-stroke actuation for 4/2 or 3/2 directional spool valves – 45 W power – 100% duty cycle	200	200	
MD 1 MD 2 MD 8	12 V DC 24 V DC 230 V AC	Double-stroke actuation for 4/3 or 3/3 directional spool valves – 45 W power – 100% duty cycle	200	200	
Size 2, 3					
ME 2/12 ME 2/24 ME 2/230 W	12 V DC 24 V DC 230 V AC	Single-stroke actuation for 4/2 or 3/2 directional spool valves – 60 W power – 100% duty cycle	200	200	
MD 2/12 MD 2/24 MD 2/230 W	12 V DC 24 V DC 230 V AC	Double-stroke actuation for 4/3 or 3/3 directional spool valves – 60 W power – 100% duty cycle	200	200	
MU 2/24	24 V DC	Reversal stroke actuation (detent) for 4/2 or 3/2 directional spool valves – 60 W power – 100% duty cycle The switching position can be changed with a current pulse of approx. 0.2 to 0.5 s	200	200	
ME 23/12 ME 23/24 ME 23/230 W	12 V DC 24 V DC 230 V AC	Single-stroke actuation for 4/2 or 3/2 directional spool valves – 150 W power – S3 35% duty cycle 5 min	315	200	
MD 23/12 MD 23/24 MD 23/230 W	12 V DC 24 V DC 230 V AC	Double-stroke actuation for 4/3 or 3/3 directional spool valves – 150 W power – S3 35% duty cycle 5 min	315	200	

Coding	Rated voltage	Description	Pressure p _{max} (bar)		Circuit symbol
			P, A, B	R	
Size 2, 3, 5					
ME 3/12 ME 3/24 ME 3/230 W	12 V DC 24 V DC 230 V AC	Single-stroke actuation for 4/2 or 3/2 directional spool valves – 65 W power – 100% duty cycle	Size 2, 3: 315 Size 5: 200	200	
MD 3/12 MD 3/24 MD 3/230 W	12 V DC 24 V DC 230 V AC	Double-stroke actuation for 4/3 or 3/3 directional spool valves – 65 W power – 100% duty cycle	Size 2, 3: 315 Size 5: 200	200	

Actuation supplement

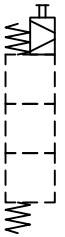
Coding	Description	Circuit symbol
Without coding	Standard version without manual override	--
N	Special version with manual override	

! DAMAGE
Permitted pressure at R during use is only approx. 40 bar! For size 5, to protect switching reliability, the flow rate $Q_{A,B \rightarrow R}$ must not exceed 160 lpm.

Manual override

1. To use, insert until you can feel the locking pin, then turn until the pin has engaged completely in the groove.

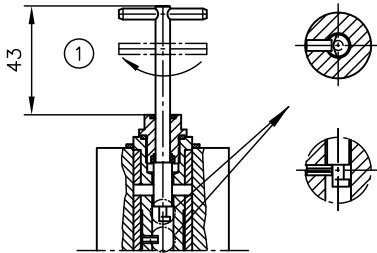

Rest position

1 pulled up

2. Locate switching position

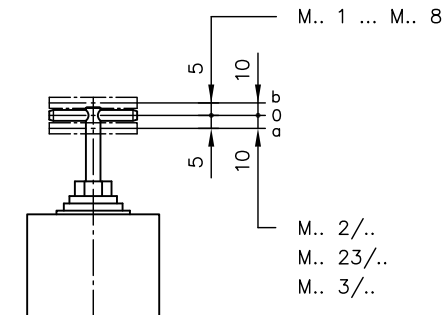

3. After use, disengage and pull up to the stop (tommy bar in rest position again).

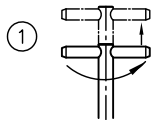

1 Disengage and pull up

! DAMAGE
The disengage and pull up steps are crucial to prevent malfunctions, especially faulty switching, when pressure is exerted at the return connection (series connection) of several spool valves.

2.5 Pressure setting

Coding	Description
Without coding	Without pressure-limiting valve
-..	with pressure-limiting valve Adjustment range see Chapter 2.3, "Pressure-limiting valve (only type SG)"

Pressure adjustment for the pressure-limiting valve

Coding	Δp (bar)/revolution	
	SG 0, 1	SG 2, 3, 5
B	100	80
C	55	35
E	19	17.5

3 Parameters

3.1 General data

Designation	Directional spool valve
Design	Spool valve
Model	Single valve for pipe connection or manifold mounting
Material	Steel, internal functional parts hardened and ground, SG valves: spool blocks zinc coated
Attachment	Mounting thread or tapped holes, see Chapter 4, "Dimensions"
Installation position	any
Ports/connections	<ul style="list-style-type: none"> ▪ P = Pump ▪ R = Reflux ▪ A, B = Consumers ▪ 1, 2 = pilot pressure for pneumatic or hydraulic actuation <p>Connecting thread: P, R, A, B: see Chapter 2.1, "Basic type and size" 1, 2: G 1/8 for size 0, 1 or G 1/4 for size 2, 3, 5 (ISO 228/1)</p>
Hydraulic fluid	Hydraulic fluid, according to DIN 51 524 Parts 1 to 3; ISO VG 10 to 68 according to DIN ISO 3448 Viscosity range: 4 - 1500 mm ² /s Optimal operating range: approx. 10 - 500 mm ² /s Also suitable for biologically degradable hydraulic fluids type HEPG (polyalkylene glycol) and HEES (synthetic ester) at operating temperatures up to approx. +70°C. Not suitable for HETG such as rapeseed oil and water-glycol solutions, e.g. HFA and HFC.
Cleanliness level	ISO 4406 <hr style="width: 20%; margin-left: 0;"/> 20/17/14
Temperatures	Environment: approx. -40 to +80 °C, hydraulic fluid: -25 to +80 °C, pay attention to the viscosity range. Start temperature: down to -40 °C is permissible (take account of the start viscosities!), as long as the steady-state temperature is at least 20 K higher during subsequent operation. Start temperature: down to -20 °C is permissible (take account of the start viscosities!), as long as the steady-state temperature is at least 20 K higher during subsequent operation. Biologically degradable hydraulic fluids: note manufacturer specifications. With consideration for the seal compatibility, not above +70°C.

3.2 Pressure and volumetric flow

Operating pressure	$p_{max} = 400$ bar (ports P, A, B) Return pressure at port R: see Chapter 2.3, "Pressure-limiting valve (only type SG)" see Chapter 2.4.1, "Manual actuation"
Flow rate	Q_{max} : see Chapter 2.1, "Basic type and size"

3.3 Weight

All dimensions in kg.

Single valve without pressure-limiting valve	Type	Manual actuation	Mechanical actuation	Hydraulic or pneumatic actuation		Electrical actuation					
		AK, AKS, CK, CKS, PK, UK	RE, BE	NE, ND, NU, NM	KD, KM	ME	MD	ME 2, ME 23	MD 2, MD 23, MU 2	ME 3	MD 3
	SG 0, 1 SP 1	1.0	1.1	0.9	-	1.4	1.7	-	-	-	-
	SG 2, 3 SP 3	3.5	2.7	2.5	2.9	-	-	3.9	5.0	4.5	4.8
	SG 5	3.9	3.1	2.9	3.3	-	-	4.3	5.4	4.9	5.1
	SP 5	4.8	4.0	3.8	4.2	-	-	5.2	6.3	5.8	6.6

Single valve with pressure-limiting valve	Type	Manual actuation	Mechanical actuation	Hydraulic or pneumatic actuation		Electrical actuation					
		AK, AKS, CK, CKS, PK, UK	RE, BE	NE, ND, NU, NM	KD, KM	ME	MD	ME 2, ME 23	MD 2, MD 23, MU 2	ME 3	MD 3
	SG 0, 1	1.2	1.3	1.1	-	1.6	1.9	-	-	-	-
	SG 2, 3	3.8	3.0	2.8	3.2	-	-	4.2	5.3	4.8	5.0
	SG 5	5.2	4.4	4.2	4.6	-	-	5.6	6.7	6.2	7.0

3.4 Characteristic lines

Viscosity of the hydraulic fluid approx. 60 mm²/s

Pressure difference P → A/B and A/B → R

All values without fittings (type SG) or connection block (type SP)

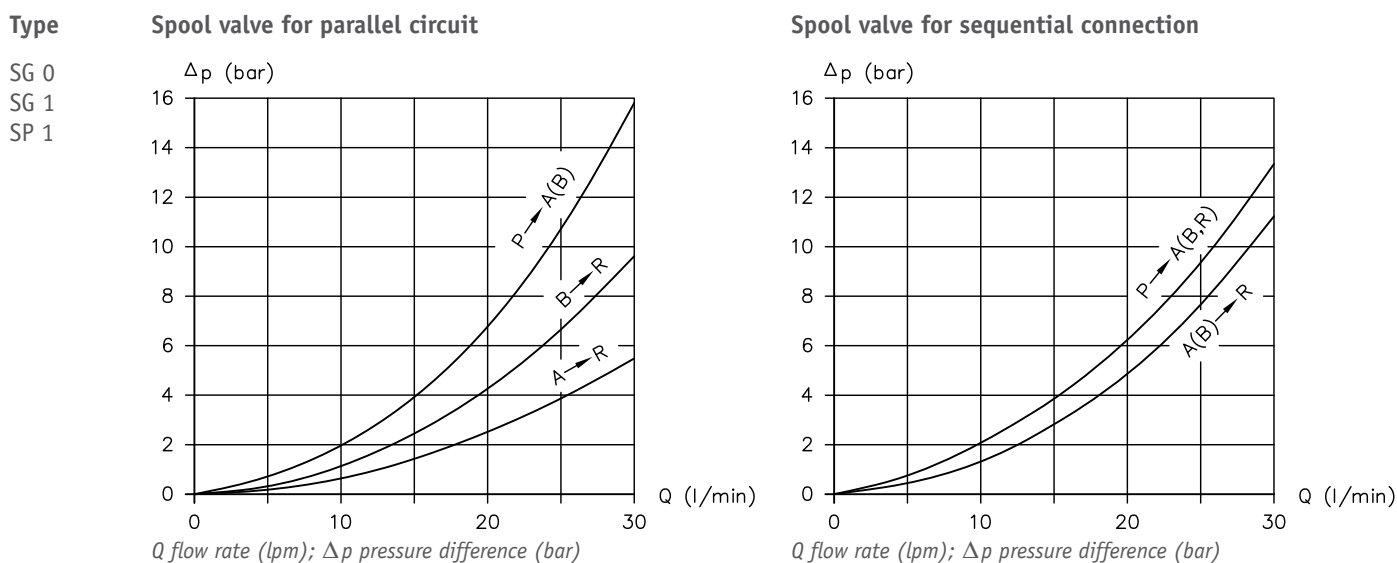

Type **Spool valve for parallel circuit**

SG 2

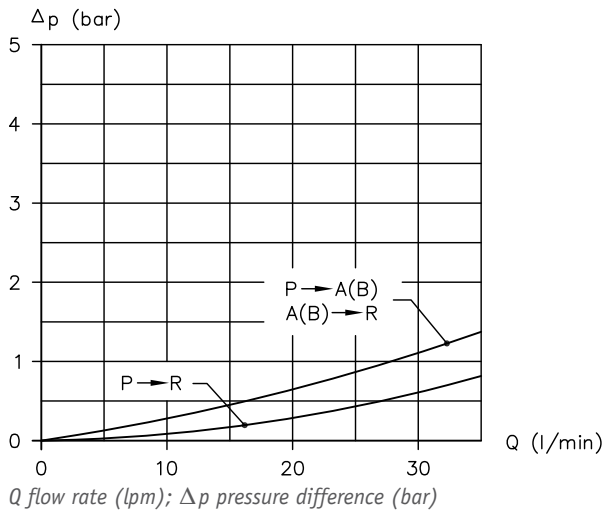

Spool valve for sequential connection

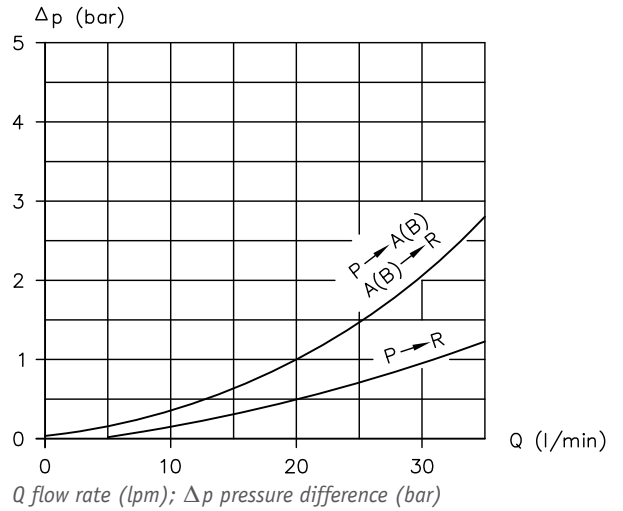

SG 3

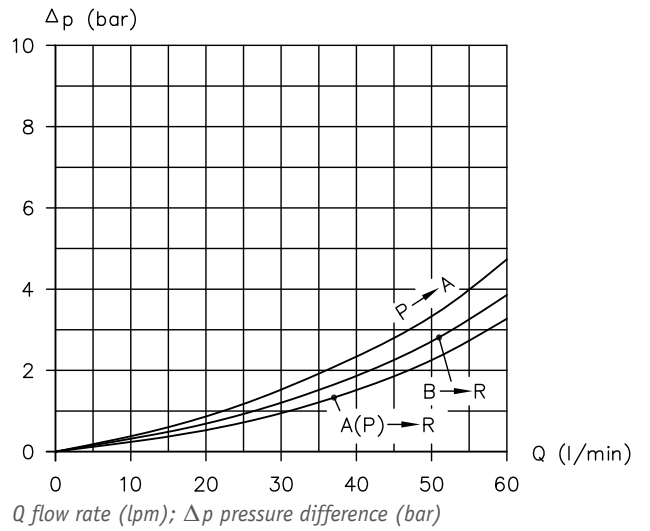
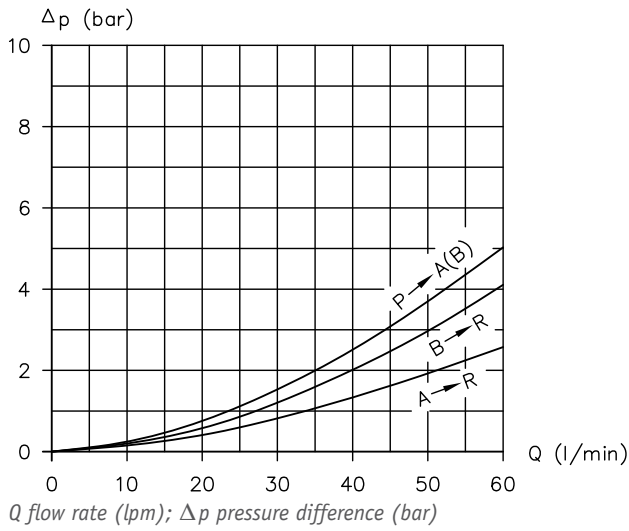

SP 3

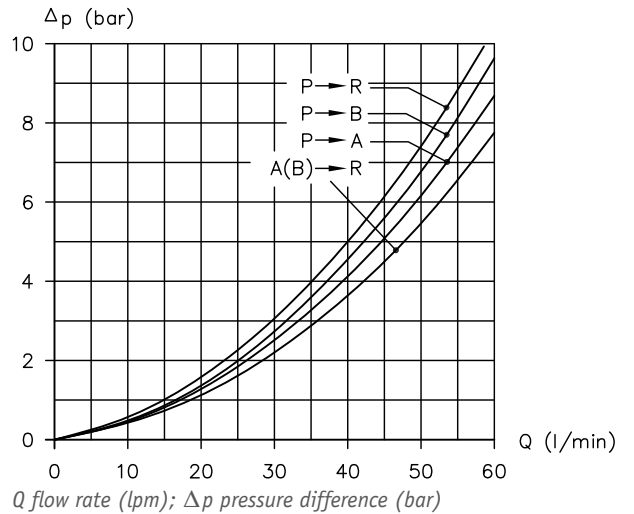
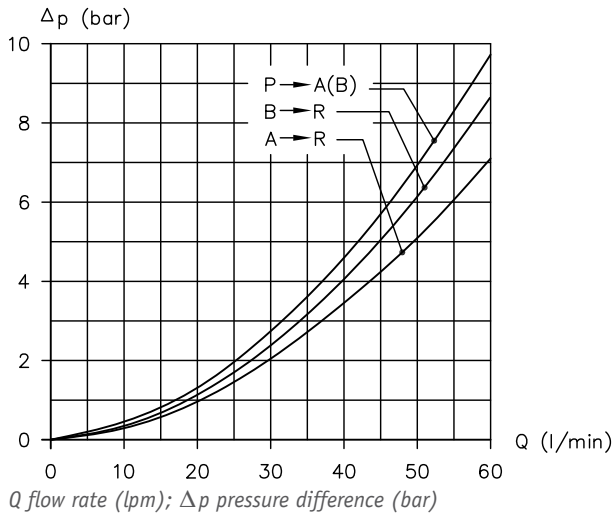

Type Spool valve for parallel circuit

SG 5
SP 5

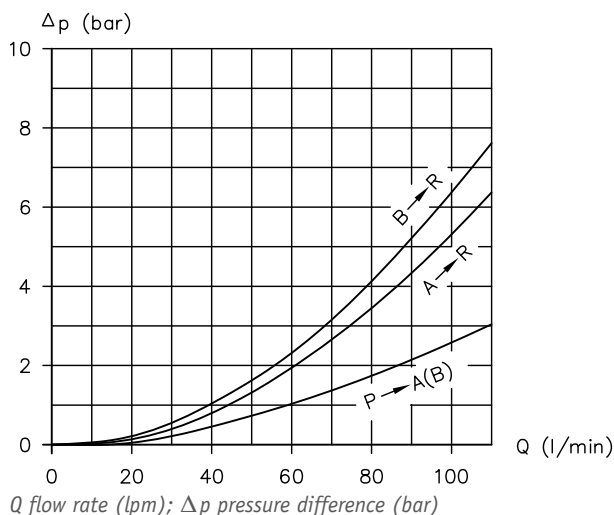

Type Spool valve for sequential connection

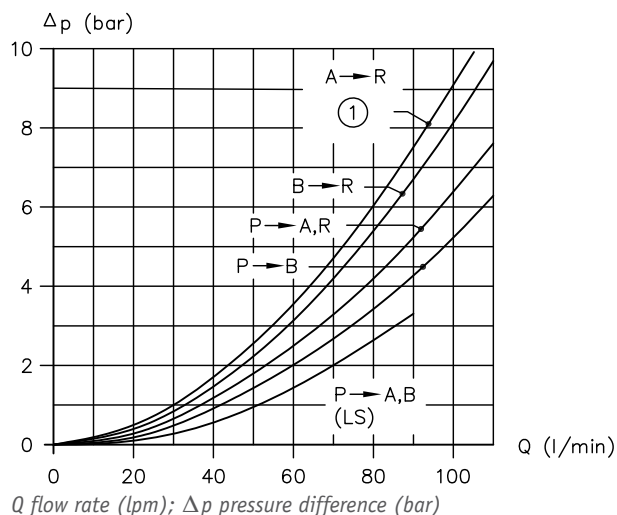

1 A, B → R for LS

3.5 Electrical data

3.5.1 Electrical actuation

Black-white solenoids, pressure-sealed in hydraulic fluid.

Nominal power		45 W	60 W	150 W	65 W
Nominal voltage	12 V DC	1	2/12	23/12	3/12
	24 V DC	2	2/24	23/24	3/24
	230 V AC	8	2/230 W	23/230 W	3/230 W
Insulation class		H	F	H	F
Max. winding temperature		180 °C	155 °C	180 °C	155 °C
Contact temperature at 20° ambient temperature		approx. 108 °C	approx. 105 °C	approx. 110 °C	approx. 90 °C
Response time		approx. 80 ms	approx. 100 ms	approx. 100 ms	approx. 100 ms
Drop-off time		approx. 100 ms	approx. 50 ms	approx. 50 ms	approx. 50 ms
Switching frequency per hour		approx. 3,600 switches			

Nominal power	45 W	60 W	150 W	65 W
Relative duty cycle at $t_s = 5$ min	S 1 (100% duty cycle)	S 1 (100% duty cycle)	S 3-35 % (35% duty cycle)	S 1 (100% duty cycle)
	<p>ϑ Ambient temperature ($^{\circ}\text{C}$); % relative duty cycle</p> <p>1 Direct current operation DC 2 Alternating current operation AC</p>			
Cut-off energy W	≤ 0.5 Ws			

Dwell time under pressure

DAMAGE

The reference values below should not be exceeded for the dwell time under pressure in switching position a or b with ME or MD solenoids (spring return), if possible, to prevent seizing due to microfne dirt particles in the oil (edge filter effect).

- 150 bar \leq 10 min
- 200 bar \leq 5 min
- 250 bar \leq 30-40 s
- 300 bar \leq 15-20 s

Longer dwell times may be possible in the event of fine filtration of the hydraulic oil.

Electrical connection

Single-action solenoid

EN 175 301-803 A
IP 67 (IEC 60529)



ME 1, ME 2,
ME 2/12, ME 2/24,
ME 23/12, ME 23/24,
ME 3/12, ME 3/24

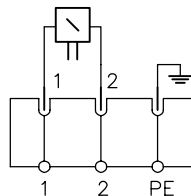

ME 8,
ME 2/230 W,
ME 23/230 W,
ME 3/230 W

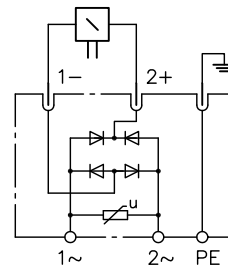

Double and reverse solenoid

EN 175 301-803 A
IP 65 (IEC 60529)



MD 1, MD 2,
MD 2/12, MD 2/24, MU 2/24,
MD 23/12, MD 23/24,
MD 3/12, MD 3/24

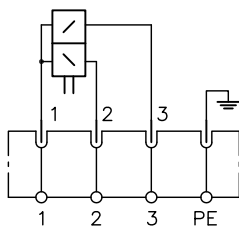

MD 8,
MD 2/230 W,
MD 23/230 W,
MD 3/230 W

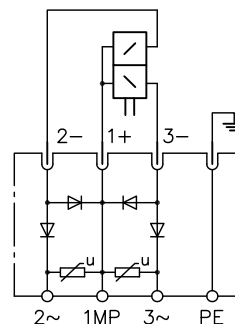

3.5.2 Contact switch

Reference values for electrical switch load (approx. 1×10^6 switching operations):

	PK (Size 0, 1)	PK, UK (Size 2, 3, 5)	Reference	
Switching capacity $\approx 10^5$ switching cycles	15 V DC	10 A	--	L/R \approx 3 ms
	24 V DC	--	5 A	$\tau \approx$ 40 ms
	30 V DC	7.5 A	--	L/R \approx 3 ms
	110 V DC	0.07 A	--	L/R \approx 3 ms
		--	0.02 A	$\tau \approx$ 40 ms
	230 V DC	0.03 A	--	L/R \approx 3 ms
	230 V AC	5 A	--	cos. $\varphi = 0.6$
		--	6 A	cos. $\varphi \geq 0.4$
Switch type	SAJA-BURGESS V3S	ELAN SEK103/S/PG11K	--	
Protection class	IP 67	IP 65	--	

4 Dimensions

All dimensions in mm, subject to change.

4.1 Single valve for pipe connection type SG

SG 0, SG 1

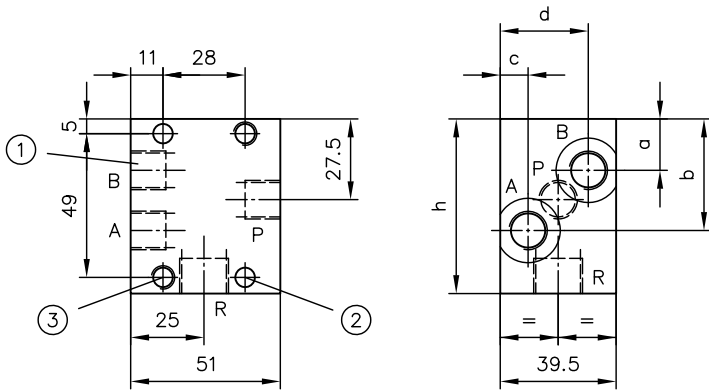

- 1 Circuit symbol coding N, S, R: Port B not present
- 2 M 8, 10 deep (rear side), core hole $\varnothing 6.5$ through
- 3 M 8, 10 deep, core hole $\varnothing 6.5$ through

Type	Circuit symbol Coding	a	b	c	d	h	Ports to ISO 228-1	
							P, A, B	R
SG 0	D, E, G, W, R	17.5	38	9.5	30	59.5	G 1/4	G 3/8
	L, P, V	21.5	33,5					
SG 1	All circuit symbols	18.5	40	11	28,5	59.5	G 3/8	G 3/8

Version with pressure-limiting valve SG 0, SG 1

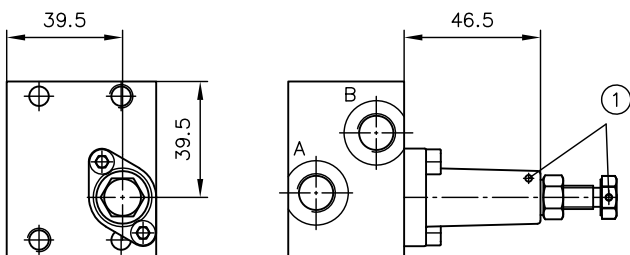

- 1 Sealing option

Fixed

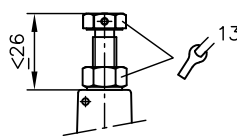

Adjustable

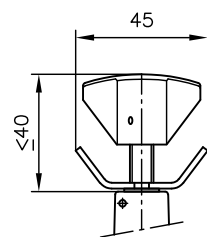

SG 2, SG 3

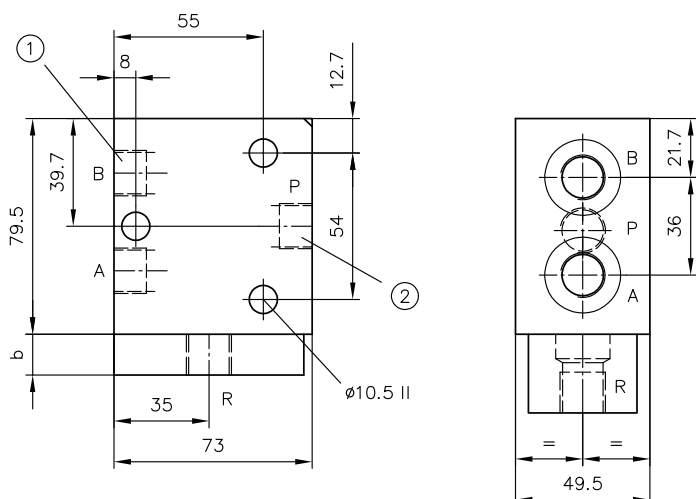

- 1 Circuit symbol coding N, S, R, U: Port B not present
- 2 Circuit symbol coding Y: Ports P and A are interchanged

Type	Circuit symbol Coding	b	Ports to ISO 228-1
			P, A, B, R
SG 2	All circuit symbols	15	G 3/8
SG 3	Y	29	G 1/2
	Other circuit symbols	15	

Version with pressure-limiting valve SG 2, SG 3

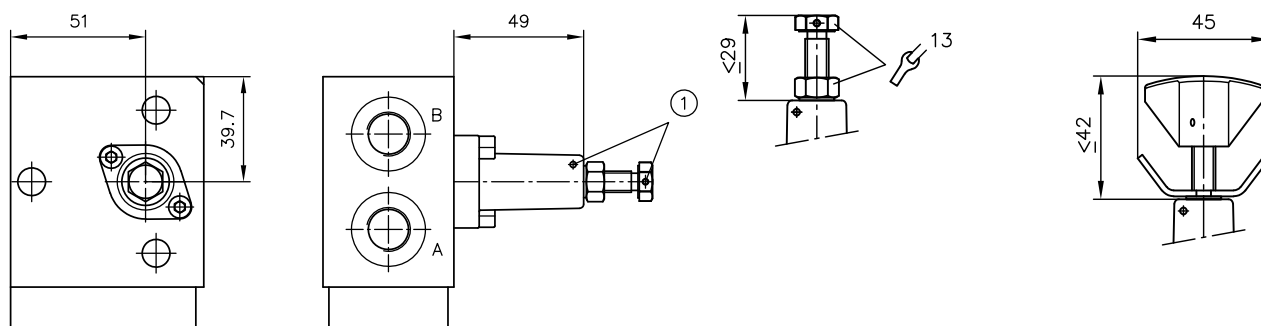

- 1 Sealing option

SG 5

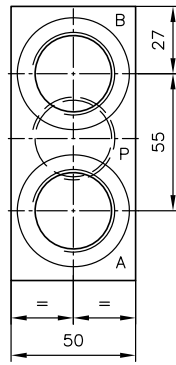
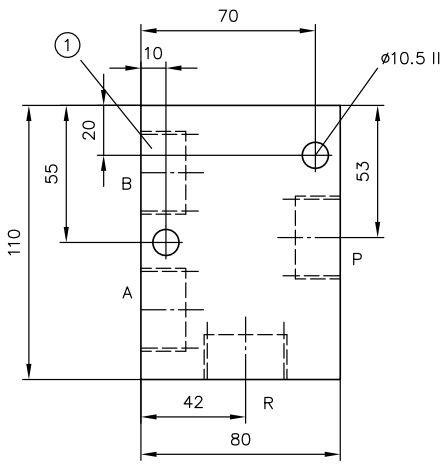

1 Circuit symbol coding N, R: Port B not present

Ports to ISO 228-1

P, A, B, R

G 1

Version with pressure-limiting valve SG 5

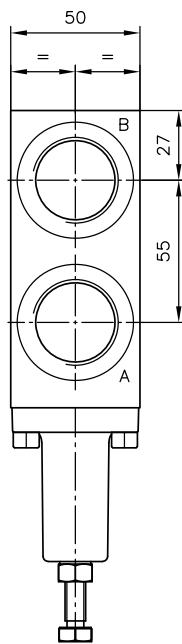
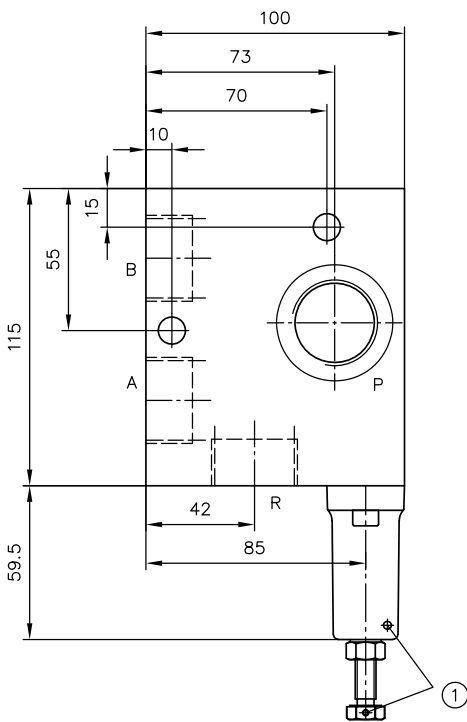

1 Sealing option

Fixed

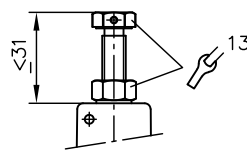

Adjustable

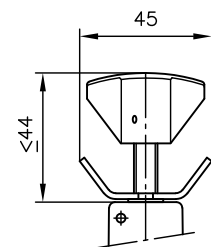

4.2 Single valve for manifold mounting, type SP

SP 1

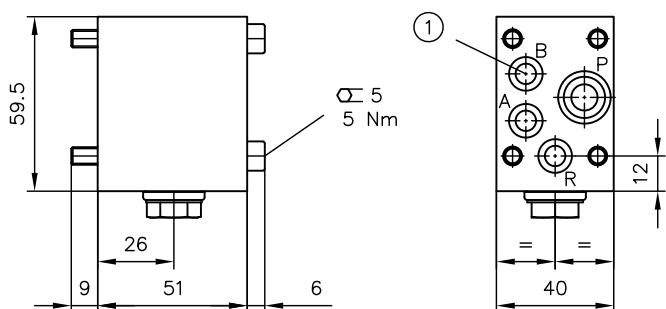

1 For circuit symbol coding N, R without port B

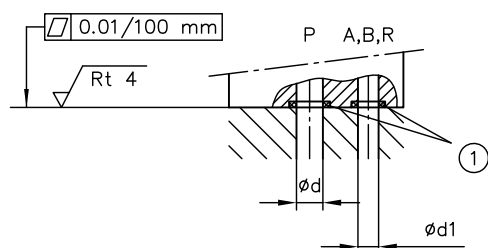

1 O-ring NBR 90 Sh

Hole pattern of the base plate

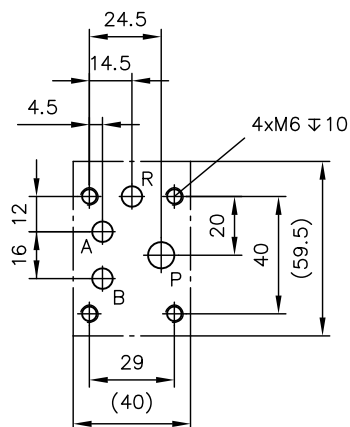

Ports	ϕd	$\phi d1$	O-ring
A, B, R	--	7	8x2
P	7 to 9	--	14x2

SP 3

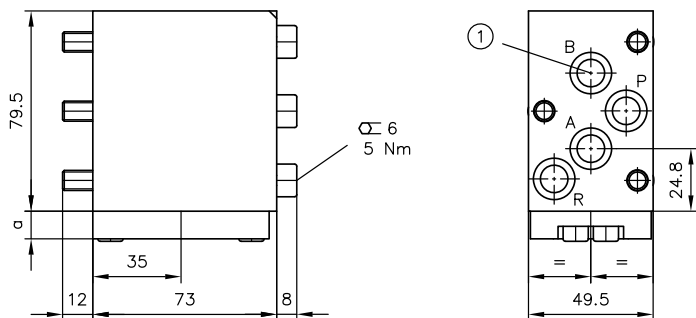

1 Circuit symbol coding N, R: Port B not present

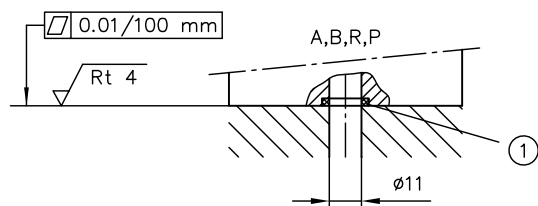

1 O-ring 12x2.5 NBR 90 Sh

Hole pattern of the base plate

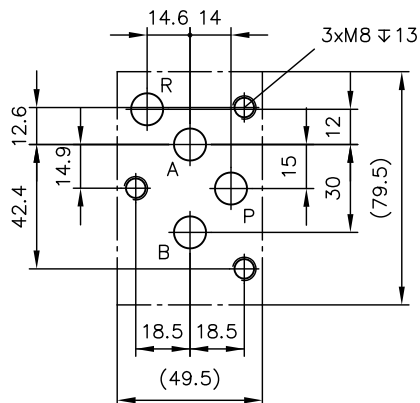

Circuit symbol coding	a
D, E, G, N, R, V, W	11
L, P	15

SP 5

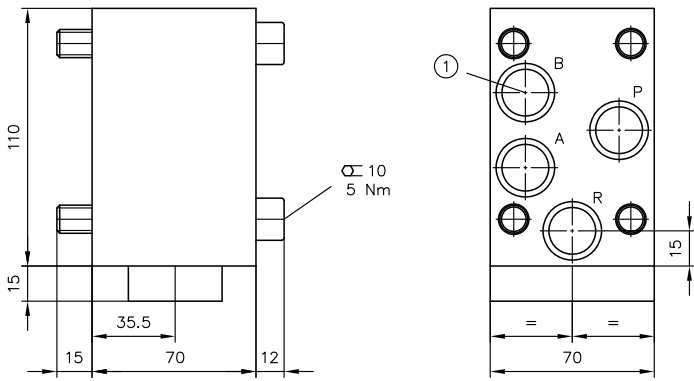

1 Circuit symbol coding N, R: Port B not present

Hole pattern of the base plate

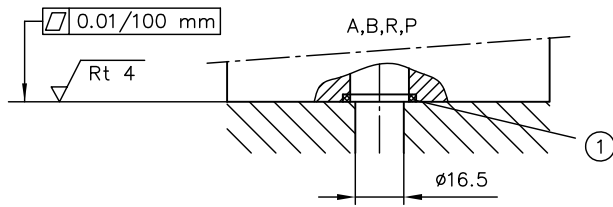
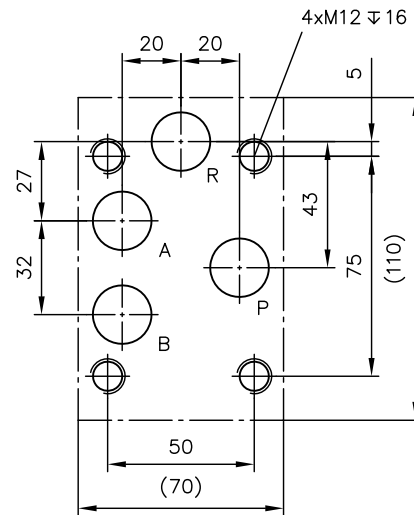

1 O-ring 20x2.5 NBR 90 Sh

4.3 Actuations

4.3.1 Manual actuations

! DAMAGE

Actuation housing can be mounted turned through 180°.

Actuation **AK, AKS, CK, CKS**

Size 0, 1

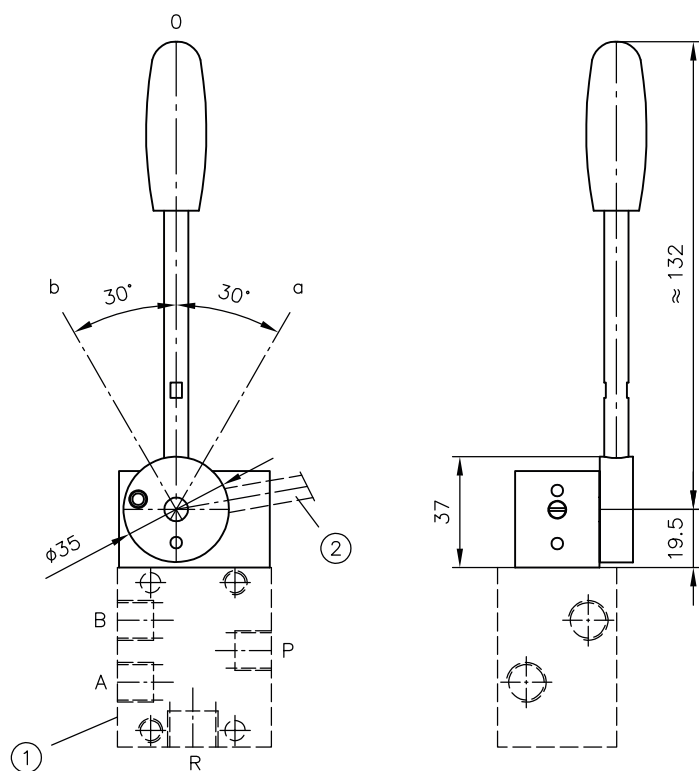

1 Flange face for directional spool valve type SP 1

2 Hand lever can be attached here

Actuation **AK, CK**
Size 2, 3, 5

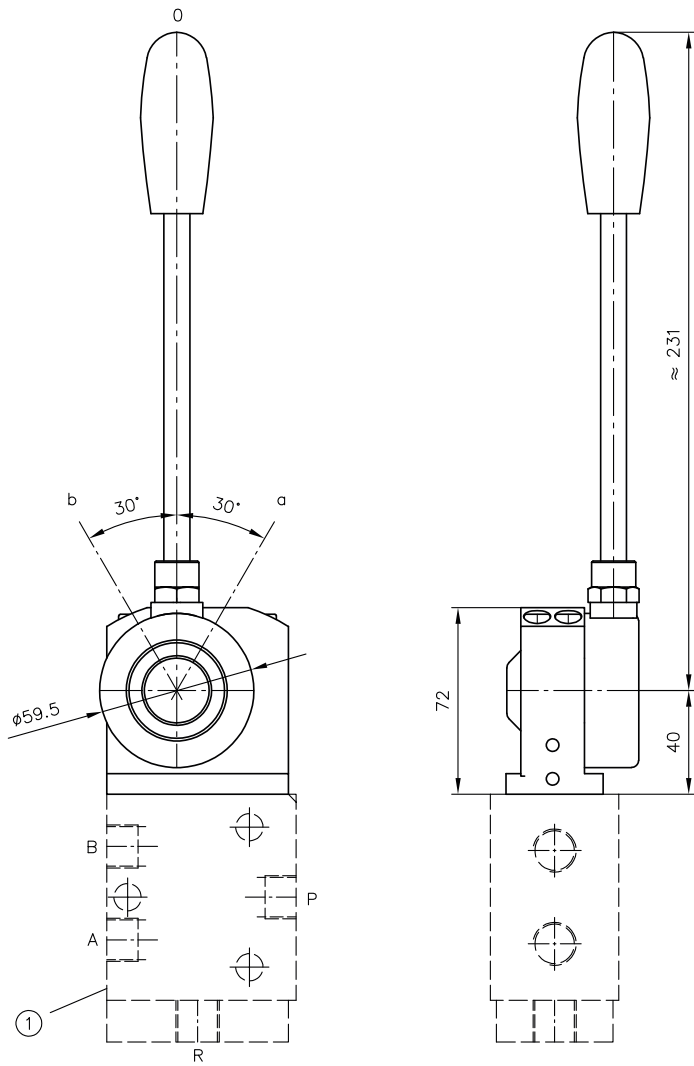

1 Flange face for directional spool valve type SP 3, 5

Actuation **AKS, CKS**
Size 2, 3, 5

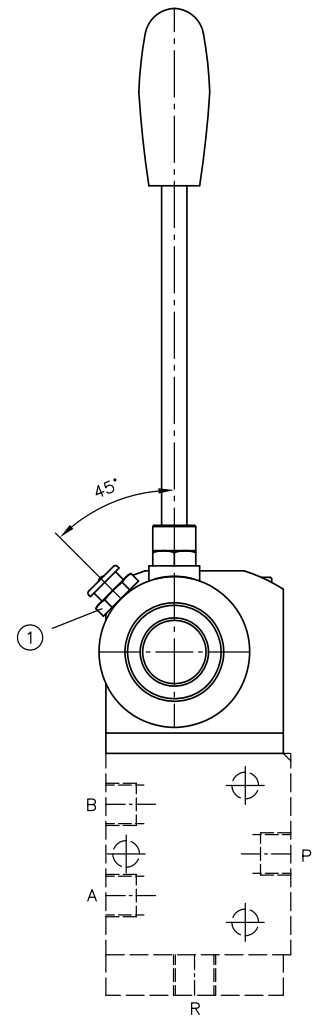

1 Flat grease nipple M10 DIN 3404 for type AKS, CKS and YKS

4.3.2 Mechanical actuations

Actuation **RE**

Size 0, 1

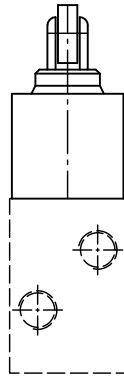
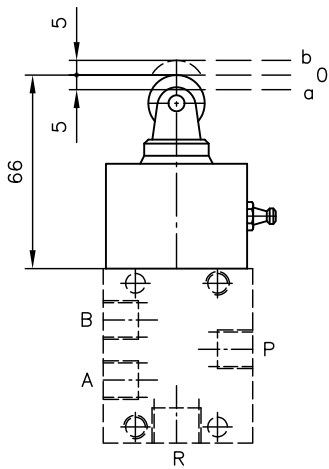

Actuation **RE**

Size 2, 3, 5

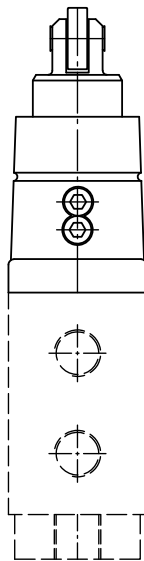
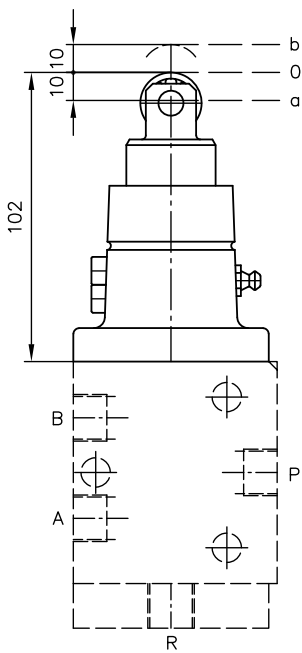

Actuation **BE**

Size 2, 3, 5

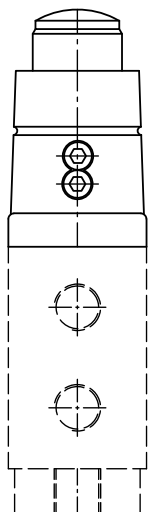
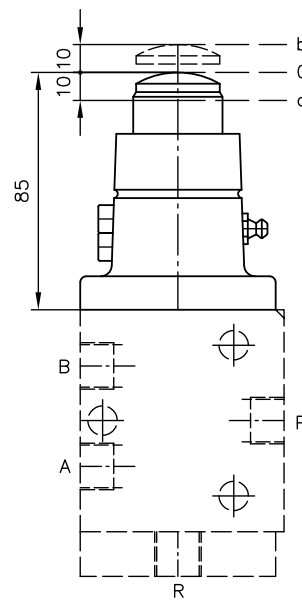

4.3.3 Hydraulic and pneumatic actuations

! DAMAGE

Actuation housing can be mounted turned through 180°.

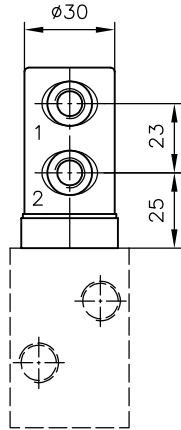
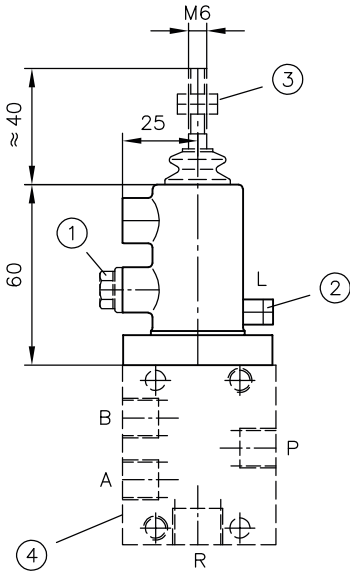

Ports to ISO 228-1

1, 2 G 1/8

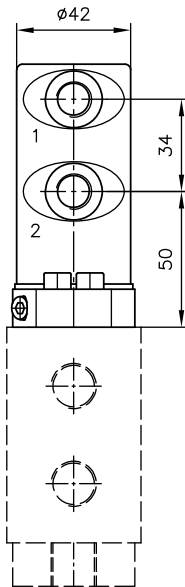
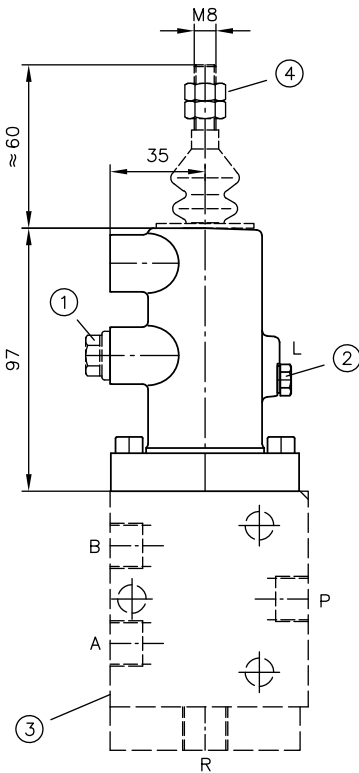

Ports to ISO 228-1

1, 2 G 1/4

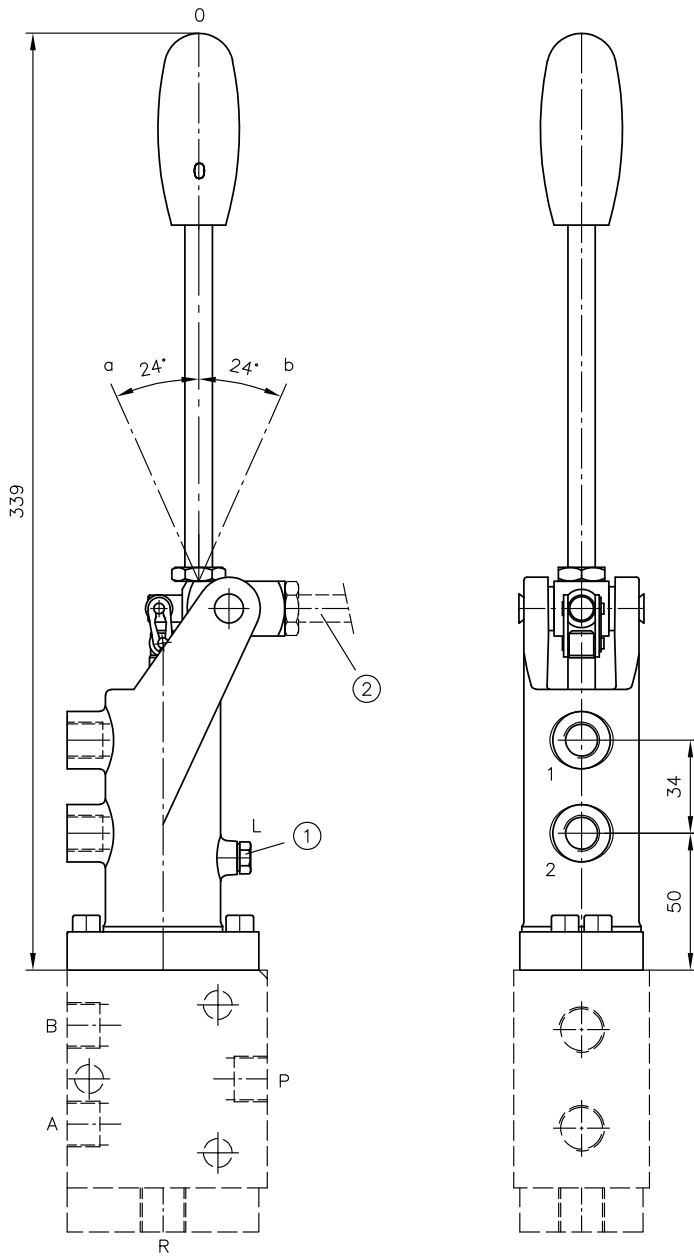

Ports to ISO 228-1

1, 2 G 1/4

4.3.4 Electrical actuations

Actuation ME 1, 2, 8

Size 0, 1

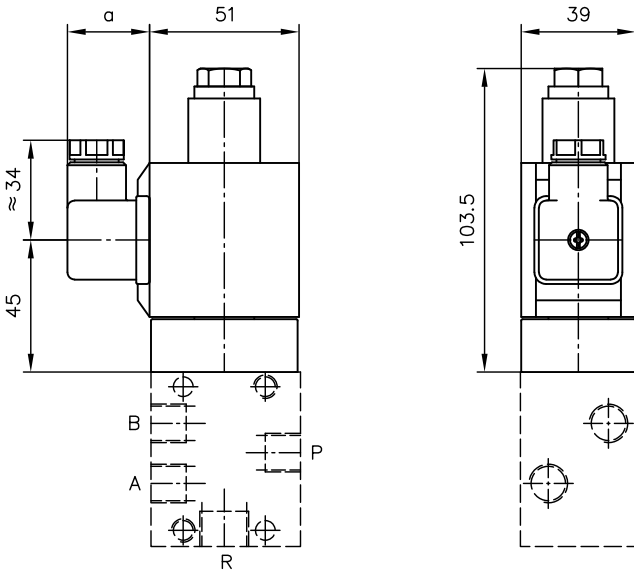

Coding	a
ME 1, ME 2	28
ME 8	35

Actuation MD 1, 2, 8

Size 0, 1

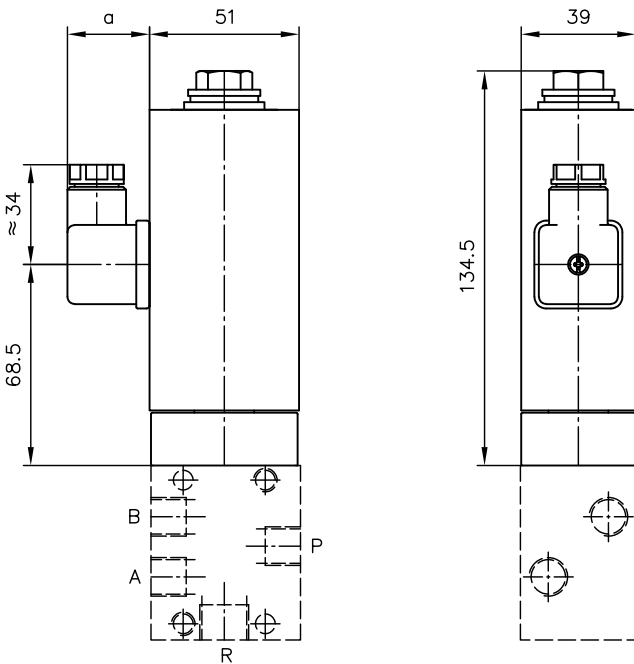

Coding	a
MD 1, MD 2	28
MD 8	35

Actuation ME 2/.., ME 23/..
Size 2, 3

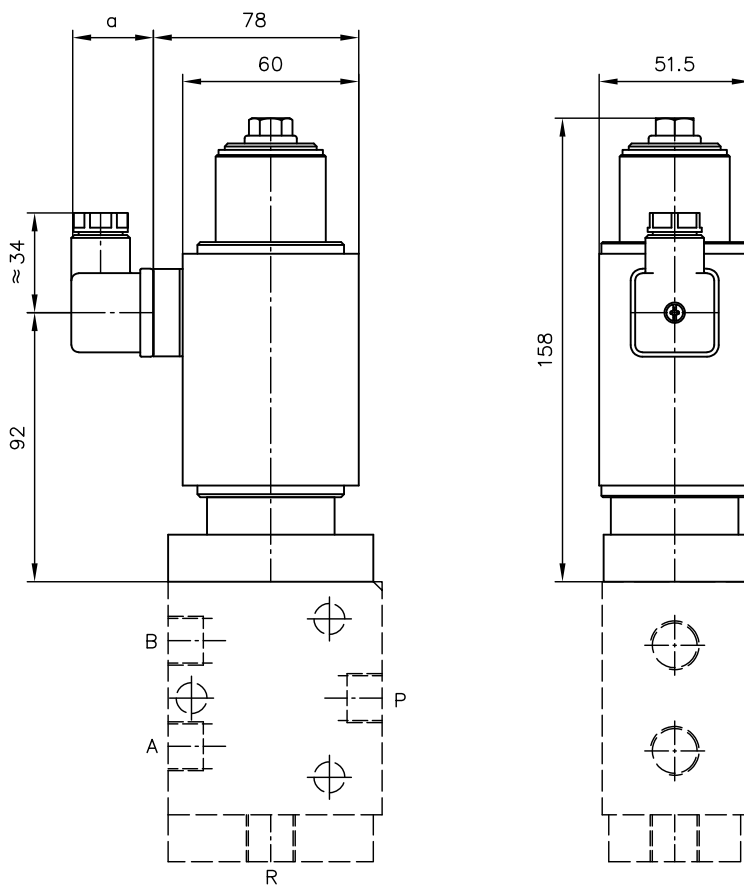

Coding	a
ME 2/12, ME 2/24, ME 23/12, ME 23/24	28
ME 2/230 W, ME 23/230 W	35

Actuation MD 2/.., MU 2/.., MD 23/...
Size 2, 3

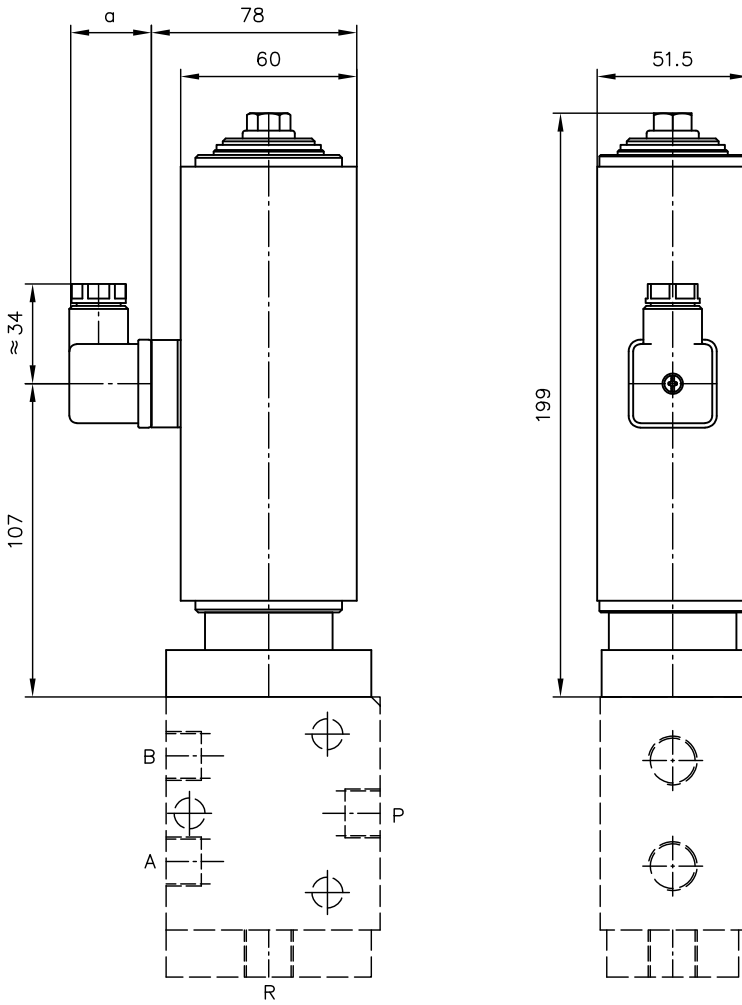

Coding	a
MD 2/12, MD 2/24, MD 23/12, MD 23/24, MU 2/24	28
MD 2/230 W, MD 23/230 W	35

Actuation ME 3/..
Size 2, 3, 5

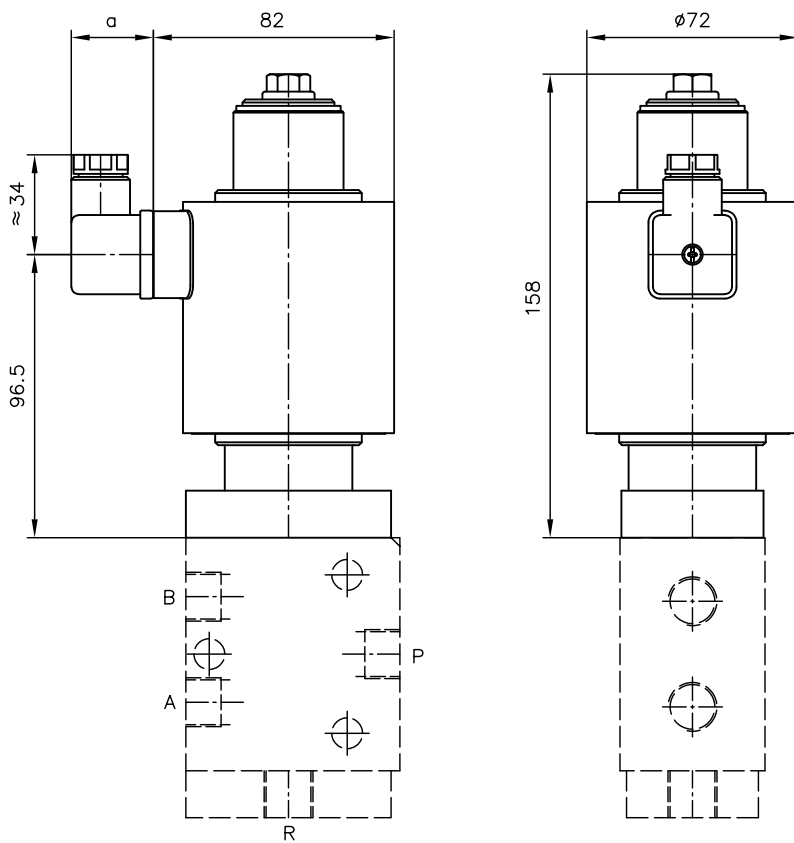

Coding	a
ME 3/12, ME 3/24	28
ME 3/230 W	35

Actuation MD 3/..
Size 2, 3, 5

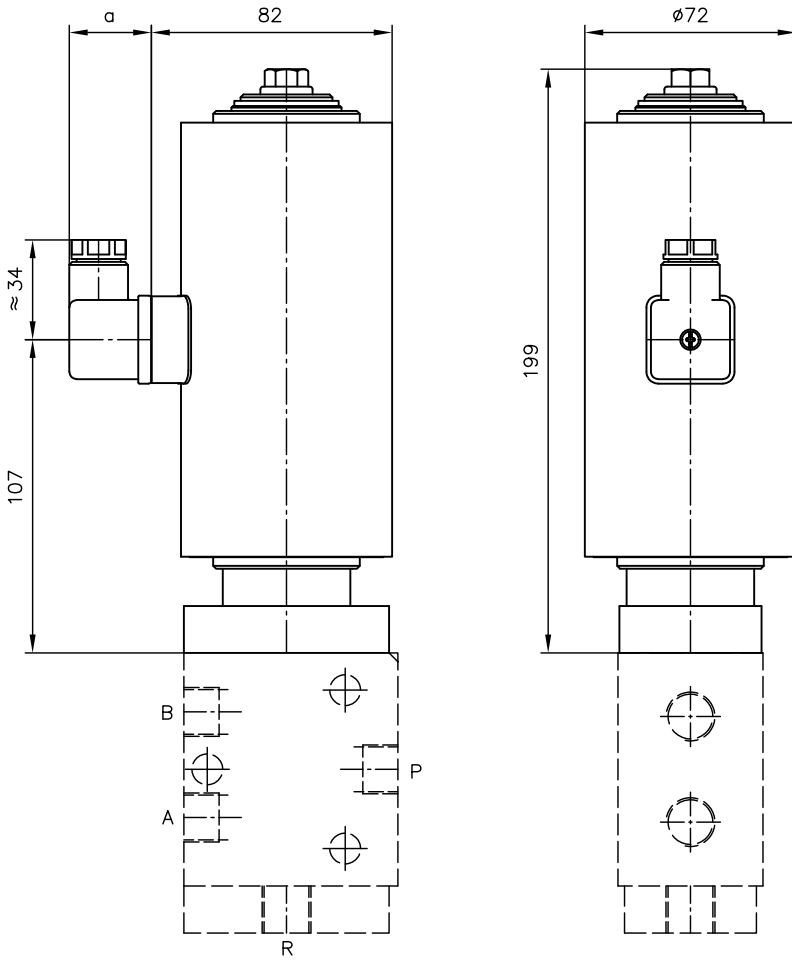

Coding	a
MD 3/12, MD 3/24	28
MD 3/230 W	35

5 Installation, operation and maintenance information

Observe the document B 5488 "General operating instructions for assembly, commissioning, and maintenance."

5.1 Intended use

This product is intended exclusively for hydraulic applications (fluid technology).

The user must observe the safety measures and warnings in this document.

Essential requirements for the product to function correctly and safely:

- ▶ All information in this documentation must be observed. This applies in particular to all safety measures and warnings.
- ▶ The product must only be assembled and put into operation by specialist personnel.
- ▶ The product must only be operated within the specified technical parameters described in detail in this document.
- ▶ All components must be suitable for the operating conditions when using an assembly.
- ▶ The operating instructions for the components, assemblies and the specific complete system must also always be observed.

If the product can no longer be operated safely:

1. Remove the product from operation and mark it accordingly.
 - ✓ It is then not permitted to continue using or operating the product.

5.2 Assembly information

The product must only be installed in the complete system with standard and compliant connection components (screw fittings, hoses, pipes, fixtures etc.).

The product must be shut down correctly prior to disassembly (in particular in combination with hydraulic accumulators).



DANGER

Sudden movement of the hydraulic drives when disassembled incorrectly

Risk of serious injury or death

- ▶ Depressurise the hydraulic system.
- ▶ Perform safety measures in preparation for maintenance.

5.2.1 Attachment

- ▶ Mount the valve on the frame or base of the machine in such a way that no stress is induced. The insertion of shim washers as packing is recommended.

SG 0, SG 1

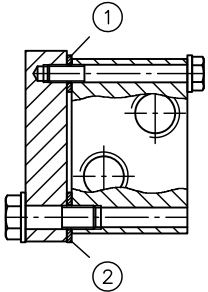

- 1 Washer
ISO 7089/7090-6,4-140 HV-A2K
- 2 Washer
ISO 7089/7090-8,4-140 - HV-A2K

SG 3, SG 5

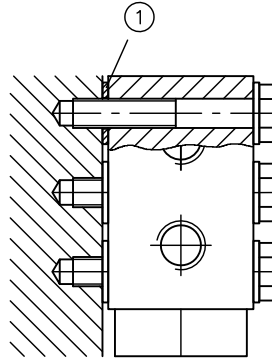

- 1 Washer
ISO 7089/7090-10,4-140 - HV-A2K

5.2.2 Pipework

- ▶ All fittings used must utilise deformable seals. The recommended tightening torque values must not be exceeded.

5.3 Operating instructions

Observe product configuration and pressure/flow rate.

The statements and technical parameters in this documentation must be strictly observed.
The instructions for the complete technical system must also always be followed.

! DAMAGE

- Read the documentation carefully before use.
- The documentation must be accessible to the operating and maintenance staff at all times.
- Keep documentation up to date after every addition or update.

⚠ CAUTION

Overloading components due to incorrect pressure settings.

Risk of minor injury.

- Pay attention to the maximum operating pressure of the pump and the valves.
- Always monitor the pressure gauge when setting and changing the pressure.

Purity and filtering of the hydraulic fluid

Fine contamination can significantly impair the function of the hydraulic component. Contamination can cause irreparable damage.

Examples of fine contamination include:

- Swarf
- Rubber particles from hoses and seals
- Dirt due to assembly and maintenance
- Mechanical debris
- Chemical ageing of the hydraulic fluid

! DAMAGE

New hydraulic fluid from the manufacturer may not have the required purity.

Damage to the product is possible.

- ▶ Filter new hydraulic fluid to a high quality when filling.
- ▶ Do not mix hydraulic fluids. Always use hydraulic fluid that is from the same manufacturer, of the same type, and with the same viscosity properties.

Adhere to the cleanliness level of the hydraulic fluid in order to maintain faultless operation.

(Also see cleanliness level in [Chapter 3, "Parameters"](#))

Additionally applicable document: [Oil recommendations: D 5488/1](#)

5.4 Maintenance information

Conduct a visual inspection at regular intervals, but at least once per year, to check if the hydraulic connections are damaged. If external leakages are found, shut down and repair the system.

Clean the device surface of dust deposits and dirt at regular intervals, but at least once per year.

References

Additional versions

- Directional spool valve type SAL: D 6449
- 4/2-way and 4/3-way directional control valve type SAM, SBM, SCM (size 6): D 6420
- 4/2-way and 4/3-way directional control valve type SAM, SBM, SCM (size 10): D 6421
- 4/2-way and 4/3-way directional control valve type SAM, SBM, SCM (size 12): D 6422
- Directional spool valve type SWPN: D 7451 AT
- Directional spool valve type NSWP 2: D 7451 N
- Directional spool valve type HSL: D 7493 L
- Directional spool valve type HSF: D 7493 E

